

# OPERATION MANUAL

## FM/AM-1000S COMMUNICATIONS SERVICE MONITOR



PUBLISHED BY  
IFR, INC.  
Wichita, Kansas

Copyright © 1981 by IFR, INC.

All rights reserved. Printed in the United States of America. No part of this publication may be reproduced, stored in a retrieval system, or transmitted in any form or by any means, electronic, mechanical, photocopying, recording or otherwise without the prior permission of the publisher.

Manual Part Number: 1002-2381-400  
Date Printed: May 1, 1981

**NOTE**

This manual part number 1002-2381-400 shall be used with FM/AM-1000S Operation Manual part number 1002-2381-200 and FM/AM-1000A Operation Manual part number 1002-2382-000.

# LIST OF EFFECTIVE PAGES

The portion of text affected by the changes is indicated by a vertical line in the outer margin of the page. Changes to illustrations are indicated by revision letter. Changes to wiring diagrams are indicated by shaded areas.

Date of issue for original and changed pages are:

Original ..... 0 ..... May 1, 1981

**TOTAL NUMBER OF PAGES IN THIS MANUAL IS 266 CONSISTING OF FOLLOWING:**

Pg. No.	Change No.	Pg. No.	Change No.	Pg. No.	Change No.
Title Page .....	0	4-73 thru 4-85 ....	0	5-25 .....	0
Copyright Page ....	0	4-86 Blank .....	0	5-26 Blank .....	0
A .....	0	4-87 thru 4-89 ....	0	5-27 .....	0
B Blank .....	0	4-90 Blank .....	0	5-28 Blank .....	0
i thru xvi .....	0	4-91 thru 4-93 ....	0	5-29 .....	0
1-1 .....	0	4-94 Blank .....	0	5-30 Blank .....	0
1-2 Blank .....	0	4-95 thru 4-111 ...	0	5-31 .....	0
2-1 thru 2-6 .....	0	4-112 Blank .....	0	5-32 Blank .....	0
3-1 Blank .....	0	4-113 thru 4-121 ..	0	5-33 .....	0
3-2 thru 3-12 .....	0	4-122 Blank .....	0	5-34 Blank .....	0
4-1 thru 4-9 .....	0	4-123 thru 4-131 ..	0	5-35 .....	0
4-10 Blank .....	0	4-132 Blank .....	0	5-36 Blank .....	0
4-11 thru 4-15 ....	0	4-133 thru 4-137 ..	0	5-37 .....	0
4-16 Blank .....	0	4-138 Blank .....	0	5-38 Blank .....	0
4-17 .....	0	4-139 thru 4-143 ..	0	A-1 thru A-5 .....	0
4-18 Blank .....	0	4-144 Blank .....	0	A-6 Blank .....	0
4-19 thru 4-25 ....	0	4-145 thru 4-153 ..	0	B-1 .....	0
4-26 Blank .....	0	4-154 Blank .....	0	B-2 .....	0
4-27 thru 4-29 ....	0	4-155 thru 4-163 ..	0	C-1 .....	0
4-30 Blank .....	0	4-164 Blank .....	0	C-2 Blank .....	0
4-31 thru 4-41 ....	0	4-165 .....	0	D-1 .....	0
4-42 Blank .....	0	4-166 .....	0	D-2 .....	0
4-43 thru 4-49 ....	0	5-1 thru 5-13 .....	0	E-1 thru E-3 .....	0
4-50 Blank .....	0	5-14 Blank .....	0	E-4 Blank .....	0
4-51 thru 4-59 ....	0	5-15 thru 5-17 ....	0	F-1 .....	0
4-60 Blank .....	0	5-18 Blank .....	0	F-2 .....	0
4-61 thru 4-67 ....	0	5-19 .....	0	G-1 .....	0
4-68 Blank .....	0	5-20 Blank .....	0	G-2 Blank .....	0
4-69 .....	0	5-21 .....	0	H-1 .....	0
4-70 Blank .....	0	5-22 Blank .....	0	H-2 .....	0
4-71 .....	0	5-23 .....	0		
4-72 Blank .....	0	5-24 Blank .....	0		

Manual pages affected by current change are denoted by asterisk.



# PREFACE

## SCOPE:

This manual contains instructions for operating the FM/AM-1000S as a general purpose communications service monitor. The instruction level of this manual is relatively basic and presupposes no previous experience on the part of the operator with a communication service monitor of this type. A basic understanding, however, of communication electronics and practical troubleshooting methods will be helpful. It is strongly recommended that operator be thoroughly familiar with Sections 1 through 3 of this manual before attempting to perform any operating procedures contained in Section 4.

## ORGANIZATION:

The operation manual is divided into the following major sections:

### SECTION 1 - INTRODUCTION

Provides a brief introduction to the FM/AM-1000S including purpose, functional capabilities and uses.

### SECTION 2 - INSTALLATION

Provides a step by step procedure for setting up the FM/AM-1000S for operation in either a mobile or test bench environment.

### SECTION 3 - DESCRIPTION OF CONTROLS, CONNECTORS & INDICATORS

Identifies and functionally describes all FM/AM-1000S controls, connectors and indicators.

### **NOTE**

- As an operating aid, Figure 3-1 (which locates and identifies all FM/AM-1000S front panel controls) has been incorporated into a fold-out page. By extending the fold-out page, the operator can easily reference any front panel control while simultaneously performing any operating procedure contained elsewhere in this manual.

### SECTION 4 - OPERATION

Contains a selection of basic operating procedures pertaining to all major functions of the FM/AM-1000S, in addition to an assortment of common receiver and transmitter tests which can be performed using the FM/AM-1000S.

### SECTION 5 - UUT RECEIVER TESTING

Contains logical flowcharts which provide operator with a systematic method of:

- a. Aligning typical AM/FM receivers.

## SECTION 5 - UUT RECEIVER TESTING (cont'd)

- b. Locating and diagnosing most common malfunctions or breakdowns in typical AM/FM receivers.

Useful supplementary information relating to the operation of the FM/AM-1000S is contained in appendices at rear of manual. (See Table of Contents for detailed list of manual contents.)

### **SUPPLEMENTARY MANUALS**

Refer to separate FM/AM-1000S Maintenance Manual for information on following topics:

- FM/AM-1000S Theory of Operation
- FM/AM-1000S Maintenance and Troubleshooting Procedures
- FM/AM-1000S Illustrated Parts Catalog
- FM/AM-1000S Assembly Drawings, PC Board Layouts and Schematics.

# TABLE OF CONTENTS

Paragraph	Title	Page
List of Effective Pages .....		A
Preface .....		i
List of Illustrations .....		ix

## SECTION 1 - INTRODUCTION

1-1	General .....	1-1
1-2	Functional Capabilities .....	1-1

## SECTION 2 - INSTALLATION

2-1	General .....	2-1
2-1-1	Safety Precautions .....	2-1
2-1-2	Equipment Inspection .....	2-2
2-1-3	Power Requirements .....	2-2
2-1-4	Installation Equipment .....	2-3
2-2	Installation Procedure .....	2-4

## SECTION 3 - DESCRIPTION OF CONTROLS, CONNECTORS & INDICATORS

3-1	FM/AM-1000S Front Panel .....	3-1
3-2	FM/AM-1000S Rear Panel .....	3-12

## SECTION 4 - OPERATION

4-1	General .....	4-1
4-1-1	Pre-operational Considerations .....	4-2
4-1-2	Operating Precautions .....	4-2

Paragraph	Title	Page
4-2	Test Procedures Using FM/AM-1000S Oscilloscope .....	4-3
4-2-1	General .....	4-4
4-2-2	Initial FM/AM-1000S Control Settings for Oscilloscope Operation .....	4-5
4-2-3	Measuring DC Voltages .....	4-7
4-2-4	Measuring Peak-to-Peak Voltages .....	4-11
4-2-5	Measuring RMS AC Voltages (Sine Wave Only) .....	4-15
4-2-6	Measuring Peak AC Voltages .....	4-17
4-2-7	Measuring Frequencies Between 5 Hz and 500 kHz .....	4-19
4-2-8	Measuring Pulse Duration and Duty Cycle .....	4-27
4-3	Test Procedures Using FM/AM-1000S Spectrum Analyzer .....	4-31
4-3-1	General .....	4-32
4-3-2	Initial FM/AM-1000S Control Settings for Spectrum Analyzer Operation .....	4-33
4-3-3	Measuring Signal Strength .....	4-35
4-3-4	Detecting Spurious Signals .....	4-39
4-4	Test Procedures Using FM/AM-1000S Dual Tone Generator ....	4-43
4-4-1	General .....	4-44
4-4-2	Initial FM/AM-1000S Control Settings for Dual Tone Generator Operation .....	4-45
4-4-3	Generating Audio Tones of Known Amplitude .....	4-47
4-4-4	Using FM/AM-1000S Speaker to Accoustically Excite a Microphone .....	4-49
4-5	Test Procedures Using FM/AM-1000S RF Generator .....	4-51



Paragraph	Title	Page
4-5-1	General .....	4-52
4-5-2	Initial FM/AM-1000S Control Settings for RF Generator Operation .....	4-53
4-5-3	Generating RF Signals .....	4-55
4-5-4	Generating AM Modulated RF Signals .....	4-57
4-5-5	Generating FM Modulated RF Signals .....	4-59
4-6	Test Procedures Using FM/AM-1000S Receiver .....	4-61
4-6-1	General .....	4-62
4-6-2	Initial FM/AM-1000S Control Settings for Receiver Operation .....	4-63
4-6-3	Receiving AM or FM Signals .....	4-65
4-6-4	Receiving Sideband Signals .....	4-69
4-6-5	Receiving CW Signals .....	4-71
4-6-6	Receiving Time Standard Signal to Calibrate FM/AM-1000S Master Oscillator .....	4-73
4-6-7	Calibrating FM/AM-1000S Master Oscillator Through an External Frequency Standard .....	4-75
4-7	Test Procedures Using FM/AM-1000S as a Sweep Generator/ Tracking Oscilloscope .....	4-77
4-7-1	General .....	4-78
4-7-2	Initial FM/AM-1000S Control Settings for Sweep Generator/ Tracking Oscilloscope Operation .....	4-79
4-7-3	Using FM/AM-1000S as a Sweep Generator/Tracking Oscilloscope .....	4-81
4-7-4	Measuring Bandpass and Center Frequency of a Bandpass Circuit .....	4-87
4-7-5	Measuring Bandreject and Center Frequency of Notch Circuits .....	4-91

Paragraph	Title	Page
4-7-6	Measuring Cut-off Frequency of Lowpass Circuits .....	4-95
4-7-7	Measuring Cut-off Frequency of Highpass Circuits .....	4-101
4-8	General Receiver Tests .....	4-107
4-8-1	General .....	4-108
4-8-2	Oscillator Frequency Measurement .....	4-109
4-8-3	Measuring RF Section Bandpass and Center Frequency (For bandpasses less than 40 kHz) .....	4-113
4-8-4	Measuring Bandpass and Center Frequency of an IF Strip ...	4-119
4-8-5	Measuring Receiver Bandpass and Center Frequency (For bandpasses less than 40 kHz) .....	4-123
4-8-6	Measuring Receiver Bandpass and Center Frequency (For bandpasses greater than 40 kHz) .....	4-127
4-8-7	Measuring Squelch Threshold and Differential (For receivers with fixed squelch) .....	4-133
4-8-8	Measuring Squelch Threshold and Differential (For receivers with variable squelch) .....	4-135
4-8-9	Measuring AGC Action .....	4-139
4-8-10	Measuring AM Receiver Sensitivity .....	4-145
4-8-11	Measuring FM Receiver 20 dB Quieting .....	4-149
4-8-12	Measuring 12 dB Sinad Sensitivity .....	4-151
4-8-13	Measuring Maximum Receivable Deviation .....	4-153
4-9	General Transmitter Tests .....	4-155
4-9-1	General .....	4-156
4-9-2	Measuring Transmitter Carrier Power .....	4-157
4-9-3	Measuring Transmitter Frequency .....	4-159
4-9-4	Measuring AM Modulation of a Transmitter .....	4-161
4-9-5	Measuring Transmitter Deviation (Below $\pm 20$ kHz) .....	4-165

**SECTION 5 - RECEIVER ALIGNMENT & TROUBLESHOOTING**

5-1	General .....	5-1
5-1-1	Preliminary Considerations .....	5-1
5-1-2	Alignment/Troubleshooting Safety Precautions .....	5-2
5-1-3	How to Use Alignment/Troubleshooting Flowcharts .....	5-3
5-2	Routine Maintenance Checklist .....	5-5
5-3	Receiver Alignment Flowchart .....	5-7
5-4	AM/FM Receiver Troubleshooting Flowcharts .....	5-11
5-4-1	Power Supply Troubleshooting Flowchart .....	5-11
5-4-2	Oscillator Troubleshooting Flowchart .....	5-15
5-4-3	RF Amplifier Troubleshooting Flowchart .....	5-19
5-4-4	IF Amplifier Troubleshooting Flowchart .....	5-21
5-4-5	Receiver Section Troubleshooting Flowchart .....	5-23
5-4-6	Squelch Troubleshooting Flowchart .....	5-25
5-4-7	AGC Troubleshooting Flowchart .....	5-27
5-4-8	AM Audio Troubleshooting Flowchart .....	5-29
5-4-9	Sensitivity Troubleshooting Flowchart .....	5-31
5-4-10	Squelch Enable Troubleshooting Flowchart .....	5-33
5-4-11	FM Audio Troubleshooting Flowchart .....	5-35
5-4-12	Maximum Receivable Deviation Troubleshooting Flowchart .....	5-37

Paragraph Title Page

**APPENDICES**

Appendix A Specifications ..... A-1

Appendix B FM/AM-1000S Standard/Optional Accessories ..... B-1

Appendix C dBm to Microvolt Conversion Chart ..... C-1

Appendix D Repacking for Shipment ..... D-1

Appendix E Sweep Generator/Tracking Oscilloscope Operation:  
Viewing Frequency Response Display Directly on  
Oscilloscope ..... E-1

Appendix F Pinout/Contact Assignments for External Accessory  
and External Modulation Connectors ..... F-1

Appendix G How to Construct an RF Pick-up ("Sniffer") Cable .... G-1

Appendix H Abbreviations & Symbols ..... H-1

# LIST OF ILLUSTRATIONS

Figure No.	Title	Page
2-1	Extending FM/AM-1000S Support Bracket .....	2-4
2-2	FM/AM-1000S Operating Position .....	2-4
2-3	Removing FM/AM-1000S Lid Retaining Plate .....	2-4
2-4	Removing FM/AM-1000S Accessories .....	2-5
2-5	FM/AM-1000S with Antenna Attached .....	2-5
2-6	Discharging Static Buildup from Antenna Coax .....	2-5
2-7	Connecting External AC or DC Power Cable to FM/AM-1000S .....	2-6
2-8	FM/AM-1000S Power Switch .....	2-6
3-1	FM/AM-1000S Front Panel .....	3-1
3-2	CRT Display Deviation Scales .....	3-8
3-3	FREQUENCY MHz Thumbwheels .....	3-8
3-4	CRT Display Graticule Markings .....	3-9
3-5	FM/AM-1000S Rear Panel .....	3-12
4-1	FM/AM-1000S Controls Applicable to Oscilloscope Operation .....	4-5
4-2	Scope Trace Centered over Major Horizontal Axis .....	4-7
4-3	Examples of DC Voltage Measurements .....	4-8
4-4	Stable Sine Wave Display .....	4-12
4-5	Negative Peaks of Sine Wave Display Resting on Horizontal Axis .....	4-12
4-6	Positive Peak of Waveform Centered over Major Vertical Axis .....	4-13

Figure No.	Title	Page
4-7	Measuring Peak-to-Peak Amplitude of Waveform .....	4-13
4-8	Examples of Closely Packed and Multiple Waveforms .....	4-20
4-9	Positive Going Zero Point of Waveform Aligned with Vertical Axis .....	4-21
4-10	Measuring Wavelength in Graticule Divisions .....	4-21
4-11	Solid Square Trace Area Displayed on CRT .....	4-22
4-12	Lissajou Figure Reference Chart .....	4-25
4-13	Typical Display of Pulse Waveform .....	4-28
4-14	Measuring "ON" Time of Pulse Waveform .....	4-28
4-15	Measuring PRT of Pulse Waveform .....	4-29
4-16	FM/AM-1000S Controls Applicable to Spectrum Analyzer Operation .....	4-33
4-17	Signal Under Test Displayed at Center Frequency .....	4-36
4-18	Signal Under Test Measured Along dB Scale of CRT .....	4-36
4-19	Signal Under Test Offset from Major Vertical Axis .....	4-37
4-20	Adjusting Injected BFO Signal to Same Amplitude of Signal Under Test .....	4-38
4-21	Typical Display of Carrier Signal and Adjacent Spurious Signal .....	4-40
4-22	FM/AM-1000S Controls Applicable to Dual Tone Generator Operation .....	4-45
4-23	Test Set-Up Diagram for Injecting Tone(s) of Known Amplitude Into a UUT .....	4-47
4-24	Amplitude of Displayed Waveform Adjusted 1 Volt Peak ....	4-48
4-25	FM/AM-1000S Controls Applicable to RF Generator Operation .....	4-53
4-26	Displayed Carrier Aligned with Lower Edge Resting on Major Horizontal Axis .....	4-57

Figure No.	Title	Page
4-27	Alignment of Upper and Lower Modulation Signals with Major Horizontal Axis .....	4-58
4-28	FM/AM-1000S Controls Applicable to Receiver Operation ...	4-63
4-29	Test Set-Up Diagram for Calibrating FM/AM-1000S Master Oscillator .....	4-75
4-30	FM/AM-1000S Controls Applicable to Sweep Generator/Tracking Oscilloscope Operation .....	4-79
4-31	Test Set-Up Diagram for Sweep Generator/Tracking Oscilloscope Operation (Using Detector) .....	4-81
4-32	Test Set-Up Diagram for Sweep Generator/Tracking Oscilloscope (Using Detector Probe) .....	4-82
4-33	Dot Positioned 3 Graticule Divisions above or below Major Horizontal Axis, on Major Vertical Axis .....	4-83
4-34	Horizontal Trace Positioned 3 Graticule Divisions above or below Major Horizontal Axis, Centered over Major Vertical Axis .....	4-83
4-35	Peak of Displayed Waveform Resting on Major Horizontal Axis .....	4-84
4-36	Frequency Response Curve of CUT .....	4-84
4-37	Bandpass Response Curve Centered over Major Vertical Axis .....	4-87
4-38	Bandpass Response Curve with One Leg Resting on Major Horizontal Axis .....	4-88
4-39	Bandpass Response Curve with Legs Resting on Major Horizontal Axis .....	4-89
4-40	Bandreject Response Curve Centered over Major Vertical Axis .....	4-91
4-41	Bandreject Response Curve with One Leg Resting on Major Horizontal Axis .....	4-92
4-42	Bandreject Response Curve with Legs Resting on Major Horizontal Axis .....	4-93

Figure No.	Title	Page
4-43	Test Set-Up Diagram for Measuring Cut-off Frequency of Lowpass Circuits (Using Detector) .....	4-95
4-44	Test Set-Up Diagram for Measuring Cut-off Frequency of Lowpass Circuits (Using Detector Probe) .....	4-96
4-45	Dot Positioned 3 Graticule Divisions above or below Major Horizontal Axis, on Major Vertical Axis .....	4-97
4-46	Horizontal Trace Positioned 3 Graticule Divisions above or below Major Horizontal Axis, Centered over Major Vertical Axis .....	4-97
4-47	Horizontal Trace Aligned with Major Horizontal Axis (Using Positive & Negative Detector) .....	4-98
4-48	Position of Horizontal Trace after Adding 3 dB to Signal Strength .....	4-99
4-49	Horizontal Trace (or Section of Frequency Response Curve) Positioned at Intersection of Major Axes .....	4-99
4-50	Test Set-Up Diagram for Measuring Cut-off Frequency of Highpass Circuits (Using Detector) .....	4-101
4-51	Test Set-Up Diagram for Measuring Cut-off Frequency of Highpass Circuits (Using Detector Probe) .....	4-102
4-52	Dot Positioned 3 Graticule Divisions above or below Major Horizontal Axis, on Major Vertical Axis .....	4-103
4-53	Horizontal Trace Positioned 3 Graticule Divisions above or below Major Horizontal Axis, Centered over Major Vertical Axis .....	4-103
4-54	Horizontal Trace Aligned with Major Horizontal Axis (Using Positive and Negative Detector) .....	4-104
4-55	Position of Horizontal Trace after Adding 3 dB to Signal Strength .....	4-105
4-56	Horizontal Trace (or Section of Frequency Response Curve) Positioned at Intersection of Major Axes .....	4-105
4-57	Test Set-Up Diagram for Oscillator Frequency Measurement .....	4-109



Figure No.	Title	Page
4-58	Oscillator Spectrum Aligned with Major Vertical Axis ....	4-110
4-59	Test Set-Up Diagram for Measuring RF Section Bandpass and Center Frequency (Using Detector) .....	4-113
4-60	Test Set-Up Diagram for Measuring RF Section Bandpass and Center Frequency (Using Detector Probe) .....	4-114
4-61	UUT Injection and Sample Points (Single Conversion Receiver) .....	4-114
4-62	UUT Injection and Sample Points (Dual Conversion Receiver) .....	4-114
4-63	Dot Positioned 3 Graticule Divisions above or below Major Horizontal Axis, on Major Vertical Axis .....	4-115
4-64	Horizontal Trace Aligned with Major Horizontal Axis (Using Positive and Negative Detector) .....	4-116
4-65	Horizontal Trace (or Section of Frequency Response Curve) Positioned at Intersection of Major Axis .....	4-117
4-66	Horizontal Trace (or Section of Frequency Response Curve) Positioned at Intersection of Major Axes .....	4-118
4-67	UUT Sample and Injection Points (Single Conversion Receiver) .....	4-119
4-68	UUT Sample and Injection Points (Dual Conversion Receiver) .....	4-119
4-69	Typical Displays of Frequency Response Curve .....	4-120
4-70	Typical Displays of Frequency Response Curve .....	4-121
4-71	UUT Injection and Sample Points (Single Conversion Receiver) .....	4-123
4-72	UUT Injection and Sample Points (Dual Conversion Receiver) .....	4-123
4-73	Typical Displays of Frequency Response Curve for Average Band Receivers .....	4-124
4-74	Typical Displays of Frequency Response Curve for Average Band Receivers .....	4-125

Figure No.	Title	Page
4-75	Typical Displays of Frequency Response Curve for Narrow Band Receivers .....	4-125
4-76	Typical Displays of Frequency Response Curve for Narrow Band Receivers .....	4-126
4-77	UUT Injection and Sample Points (Single Conversion Receiver) .....	4-127
4-78	UUT Injection and Sample Points (Dual Conversion Receiver) .....	4-127
4-79	Horizontal Trace Aligned with Major Horizontal Axis .....	4-128
4-80	Section of Frequency Response Curve Displayed Using Positive Detector .....	4-128
4-81	Section of Frequency Response Curve Displayed Using Negative Detector .....	4-129
4-82	High Edge of Frequency Response Curve Centered at Intersection of Major Vertical and Horizontal Axes (Using Positive Detector) .....	4-129
4-83	High Edge of Frequency Response Curve Centered at Intersection of Major Vertical and Horizontal Axes (Using Negative Detector) .....	4-130
4-84	Low Edge of Frequency Response Curve Centered at Intersection of Major Vertical and Horizontal Axes (Using Positive Detector) .....	4-130
4-85	Low Edge of Frequency Response Curve Centered at Intersection of Major Vertical and Horizontal Axes (Using Negative Detector) .....	4-131
4-86	Test Set-Up Diagram for Measuring Squelch Threshold and Differential (Fixed Squelch) .....	4-133
4-87	Test Set-Up Diagram for Measuring Squelch Threshold and Differential (Variable Squelch) .....	4-135
4-88	Test Set-Up Diagram for Measuring AGC Action .....	4-139
4-89	Displayed Carrier Signal Aligned with Major Horizontal Axis .....	4-140

Figure No.	Title	Page
4-90	Alignment of Upper and Lower Modulation Signals with Major Horizontal Axis .....	4-141
4-91	Modulated Signal Display .....	4-142
4-92	Scope Trace Exhibiting a Minor Amount of Noise .....	4-142
4-93	Test Set-Up Diagram for Measuring AM Sensitivity .....	4-145
4-94	Displayed Carrier Signal Aligned with Major Horizontal Axis .....	4-146
4-95	Alignment of Upper and Lower Modulation Signals with Major Horizontal Axis .....	4-147
4-96	Test Set-Up Diagram for Measuring FM Receiver 20 dB Quieting .....	4-149
4-97	Test Set-Up Diagram for Measuring 12 dB SINAD Sensitivity .....	4-151
4-98	Test Set-Up Diagram for Measuring Transmitter Carrier Power .....	4-157
4-99	Test Set-Up Diagram for Measuring AM Modulation of a Transmitter .....	4-161
4-100	Noise Level Display of Approximately 2.5 Graticule Divisions (Peak-to-Peak) .....	4-162
4-101	Negative Peaks of Modulation Envelope Resting on Major Horizontal Axis .....	4-163
4-102	Test Set-Up Diagram for Measuring Transmitter Deviation .....	4-165
5-1	Flowchart Symbol Referencing an Operating Test Procedure Contained in Section 4 .....	5-3
5-2	Flowchart Symbol Referencing a Troubleshooting Flowchart Contained in Section 5 .....	5-4
5-3	Flowchart Symbol Directing Operator to Return to "START" of "RECEIVER ALIGNMENT FLOWCHART" .....	5-4

Figure No.	Title	Page
5-4	Receiver Alignment Flowchart .....	5-7
D-1	Repacking for Shipment .....	D-2
E-1	Test Set-Up Diagram for Viewing Frequency Response Curve Directly on Oscilloscope .....	E-1
E-2	Frequency Response Curve Comparison (as viewed on oscilloscope with and without use of detector) .....	E-2
E-3	Frequency Response Curve Comparison (as viewed on oscilloscope with and without use of detector) .....	E-3
F-1	Pinouts for External Accessory Connector .....	F-1
F-2	Contact Assignments for External Modulation Connector ...	F-2
G-1	Flexible Coax Cable Preparation .....	G-1
G-2	Soldering Cable Center Conductor to Braided Shielding ...	G-1





# SECTION 1 - INTRODUCTION

## 1-1 GENERAL

The FM/AM-1000S is a portable communications service monitor capable of performing a variety of transmission test functions normally associated with most types of transceiving equipment (e.g., citizen's band radios, FM two-way radios, single sideband equipment, repeaters and AM/FM/SSB transceivers).

As a portable unit containing an internal rechargeable battery pack, operation of FM/AM-1000S is possible almost anywhere without concern for immediate power. Mobile, aircraft or marine operation is possible directly from 11 to 28 volt DC power systems, using a furnished cigar lighter adaptor plug. AC power operation is possible from 110/230 VAC, 47 to 420 Hz power services.

## 1-2 FUNCTIONAL CAPABILITIES

The FM/AM-1000S incorporates the functions of the following test instruments:

- FM/AM Receiver
- FM/AM Signal Generator
- RF Spectrum Analyzer
- RF Frequency Meter
- RF Wattmeter
- Dual Tone Generator
- RF Demodulator
- Frequency Standard
- Sweep Generator/Tracking Oscilloscope
- DC to 1 MHz Oscilloscope
- MM-100 Multimeter (Optional; see separate MM-100 Operation Manual for operating instructions.)

These capabilities permit the test set to perform numerous general purpose diagnostic functions, as well as most common transmitter/receiver performance tests, including:

### TRANSMITTER

- Frequency Error
- FM Deviation
- % AM Modulation
- Power Output
- Harmonic Content
- Distortion \*
- Frequency Stability
- Spurious Outputs

### RECEIVER

- SINAD Sensitivity \*
- Quieting Sensitivity
- Receiver Distortion (At maximum deviation)
- Frequency Stability
- Frequency Response
- Distortion \*
- Audio Power Output \*

\* Requires MM-100 Multimeter option; functions of multimeter include AC/DC voltmeter, ohmmeter, % AM modulation meter, distortion meter, SINAD meter, selectable audio loads and audio monitor.









# SECTION 2 - INSTALLATION

## 2-1 GENERAL

Installation of the FM/AM-1000S is a simple procedure which consists primarily of:

1. Setting instrument into an operating position.
2. Connecting external antenna to test set for "off-the-air" testing.
3. Furnishing electrical power to test set by connecting AC or DC power cable to available power source (unless battery operation is desired).

This section provides instructions for completing the above procedures with recommendations regarding installation/operation safety, equipment inspection, power requirements and required installation tools.

### 2-1-1 SAFETY PRECAUTIONS

Listed below are several important safety precautions which must be observed during all phases of installation and operation. IFR Inc. assumes no liability for customer's failure to comply with any of the safety precautions outlined in this manual.

#### ● COMPLYING WITH INSTRUCTIONS

Installation/operating personnel should not attempt to install or operate test set without reading and complying with all instructions contained in this manual. All procedures contained in this manual must be performed in exact sequence and manner described.

#### ● GROUNDING REQUIREMENTS

To minimize shock hazard, chassis and case of test set must be connected to an electrical ground. The FM/AM-1000S is furnished with an AC and DC power cable, each of which incorporates a ground pin for this purpose. The AC power cable is equipped with a standard 3-pin grounded plug on one end which must be connected only to a properly grounded 3-pin wall receptacle.

#### **WARNING**

- Due to potential safety hazards, use of three-prong to two-prong adaptor plug is not recommended.

The DC power cable features a cigar lighter adaptor on one end.

- OPERATING SAFETY

Due to presence of potentially lethal voltages within test set, operating personnel must not remove test equipment covers at any time. Component replacement and internal adjustments must be made by qualified maintenance personnel only.

- OBSERVING "CAUTION" & "WARNING" LABELS

Extreme care should be exercised when performing any operations preceded by a "CAUTION" or "WARNING" label. "CAUTION" labels appear where possibility of damage to equipment exists, while "WARNING" notes are used to denote a condition where a shock hazard exists, exposing personnel to possible bodily injury.

## **2-1-2 EQUIPMENT INSPECTION**

All IFR test sets are carefully inspected for material defects and are subjected to a thorough performance check prior to leaving factory. All sets are shipped to customer in excellent mechanical/electrical condition. Upon receipt of shipment, receiving personnel should:

1. Account for presence of all equipment and accessories as listed on packing slip.
2. Inspect all equipment for visible or concealed damage which may have occurred in transit. (If damage is apparent, see "RECEIVING INSPECTION/UNPACKING" sticker affixed to shipping container for "Damage Claim" procedure.)

## **2-1-3 POWER REQUIREMENTS**

The FM/AM-1000S can be powered from its internal battery pack or from AC or DC power sources. For AC operation, all test sets are normally factory wired to accept external power service generally available at installation site. Prior to making any AC power connections, installation personnel must check test set power rating against power service rating, making sure both are same. (If equipment power rating and power service do not match, refer to "FM/AM-1000S Maintenance Manual" for power supply modifications.)

### **NOTE**

- Instrument power rating information can be found on Model/Serial No. nameplate, located on bottom side of test set or in technical manual under "SPECIFICATIONS".
- An adhesive "CAUTION" sticker will be present on all sets and power cables wired for operation in a 230 VAC environment. (No sticker is present for equipment wired for 110 VAC.)

DC operation using furnished DC power cable is possible from any 12 V or 28 V power source which permits use of standard cigar lighter adaptor plug.

#### **2-1-4 INSTALLATION EQUIPMENT**

None required; all electrical connections required to ready instrument for operation can be easily made by hand, without use of any special tools.

## 2-2 INSTALLATION PROCEDURE

### POSITIONING TEST SET

1. Lift test set from shipping container and remove all packing material, tape etc. from set.
2. Extend support bracket on bottom of set to full locked position and place set on flat surface, bottom side down. (Bottom side of set has four plastic feet.)

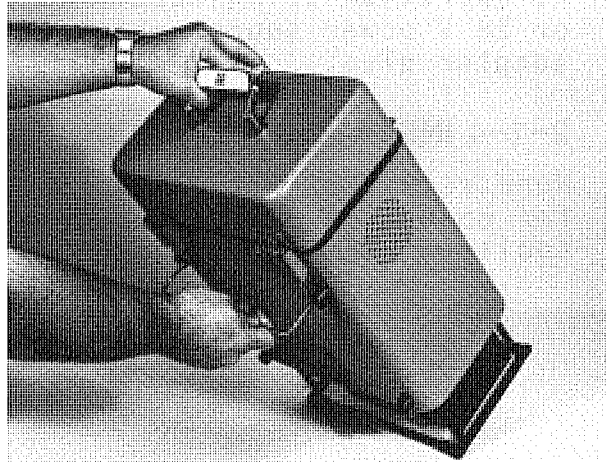

FIGURE 2-1 EXTENDING FM/AM-1000S SUPPORT BRACKETS

3. This is the most common operating position for the set when working on a bench or table. During mobile operation, set can be operated in an upright position, while resting on its metal support rails.

Unlatch and fold back lid, exposing front panel face of test set. (If desired, lid can be detached from set at hinges by sliding lid to operator's right.)



FIGURE 2-2 FM/AM-1000S OPERATING POSITION

### REMOVING SET ACCESSORIES

4. Remove retaining plate inside lid by rotating both quick-release latches counter-clockwise (ccw) and gently pulling plate straight out from lid.

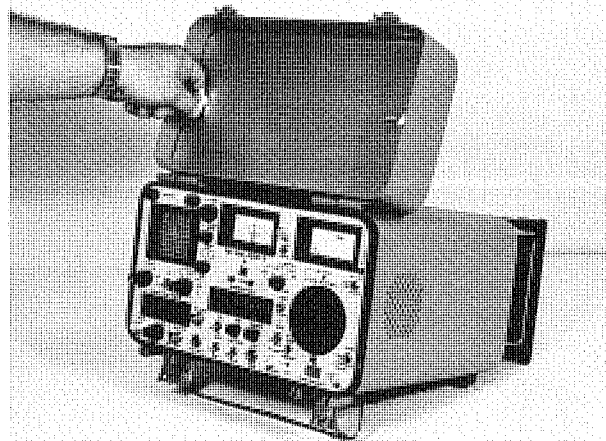
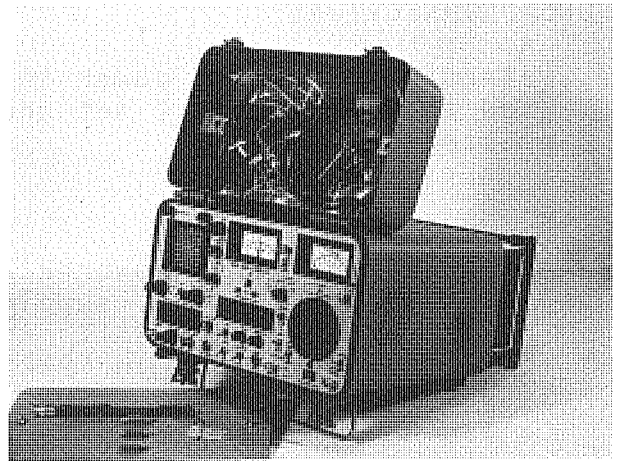

FIGURE 2-3 REMOVING LID RETAINING PLATE

5. Remove AC and DC power cables from inside of lid, along with 90° BNC connector. Note additional accessories attached to rear side of retaining plate removed in Step 4. Those accessories include:

- 3 Spare Fuses
- 1 Antenna
- 1 Allen Wrench

(See Appendix B for detailed list of FM/AM-1000S standard/optional accessories.)



**FIGURE 2-4 REMOVING FM/AM-1000S ACCESSORIES**

### CONNECTING ANTENNA

6. For "off-the-air" testing, antenna must be connected to ANT INPUT Connector (44) on front panel of test set. If test set is to be operated in an upright position, connect antenna directly to ANT INPUT Connector (44). If set is to rest on its support bracket during operation, attach antenna to furnished 90° BNC connector, then attach antenna/90° BNC connector assembly to ANT INPUT Connector (44).

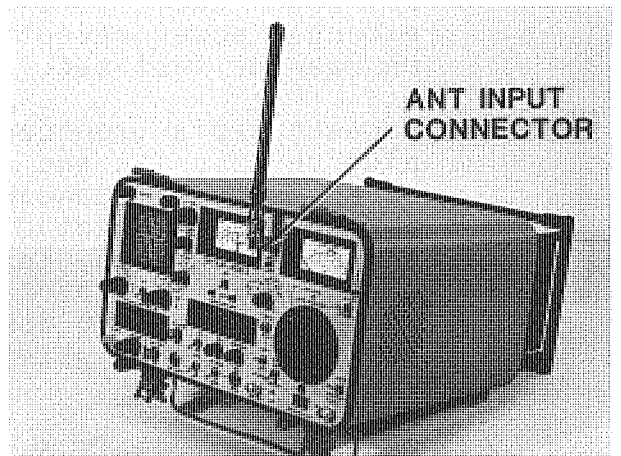

**FIGURE 2-5 FM/AM-1000 WITH ANTENNA ATTACHED**

### **CAUTION**

- If an external antenna attached to an unterminated coax cable is used, remove any possible static charge buildup before connecting coax to ANT INPUT Connector. See procedure at right.

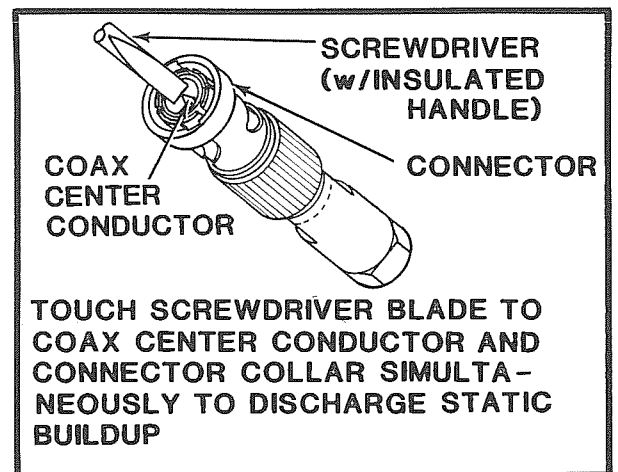

**FIGURE 2-6 DISCHARGING STATIC BUILDUP FROM ANTENNA COAX**

## POWER CONNECTIONS

7. Determine source of power to be used to energize test set and proceed accordingly:

### **CAUTION**

- When test set is powered from a vehicle's DC supply, make sure PWR/OFF/BATT Switch (9) is not in "PWR" position, while starting engine or blown fuse may result.
- a. AC or DC POWER
    - (1) Connect 6-pin socket on end of furnished AC (or DC) power cable to 6-pin external power receptacle on rear of test set.
    - (2) Connect 3-pin grounded plug on opposite end of AC power cable to standard 3-pin grounded receptacle. (For DC operation, connect cigar lighter adaptor on opposite end of DC power cable to cigar lighter socket.)
    - (3) Place PWR/OFF/BATT Switch (9) to "PWR" position to energize set.
  - b. BATTERY OPERATION
    - (1) No power cable connections required; place PWR/OFF/BATT Switch to "BATT" position to energize set.

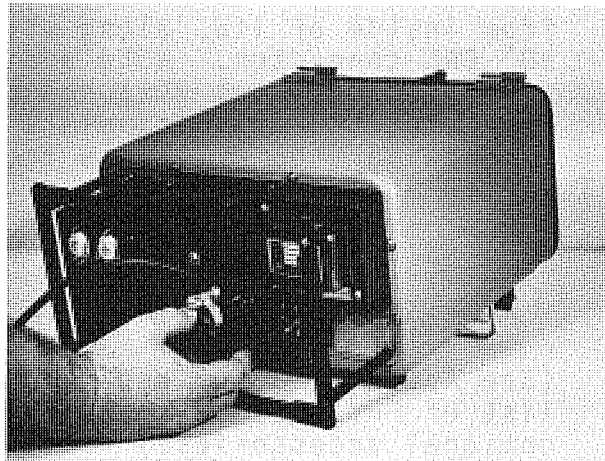

**FIGURE 2-7 CONNECTING EXTERNAL AC OR DC POWER CABLE TO FM/AM-1000S**

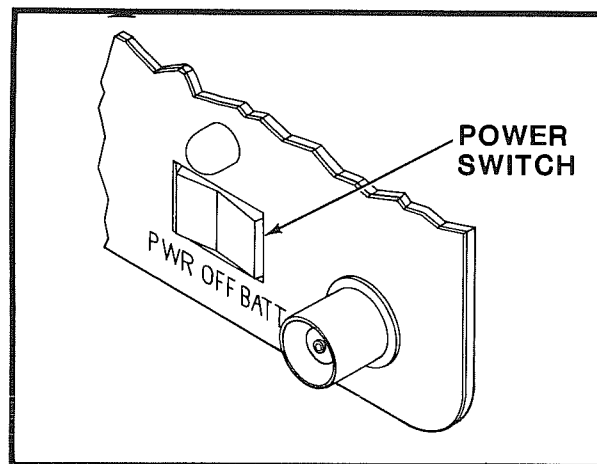

**FIGURE 2-8 FM/AM-1000S SWITCH**







# SECTION 3 - DESCRIPTION OF CONTROLS, CONNECTORS & INDICATORS

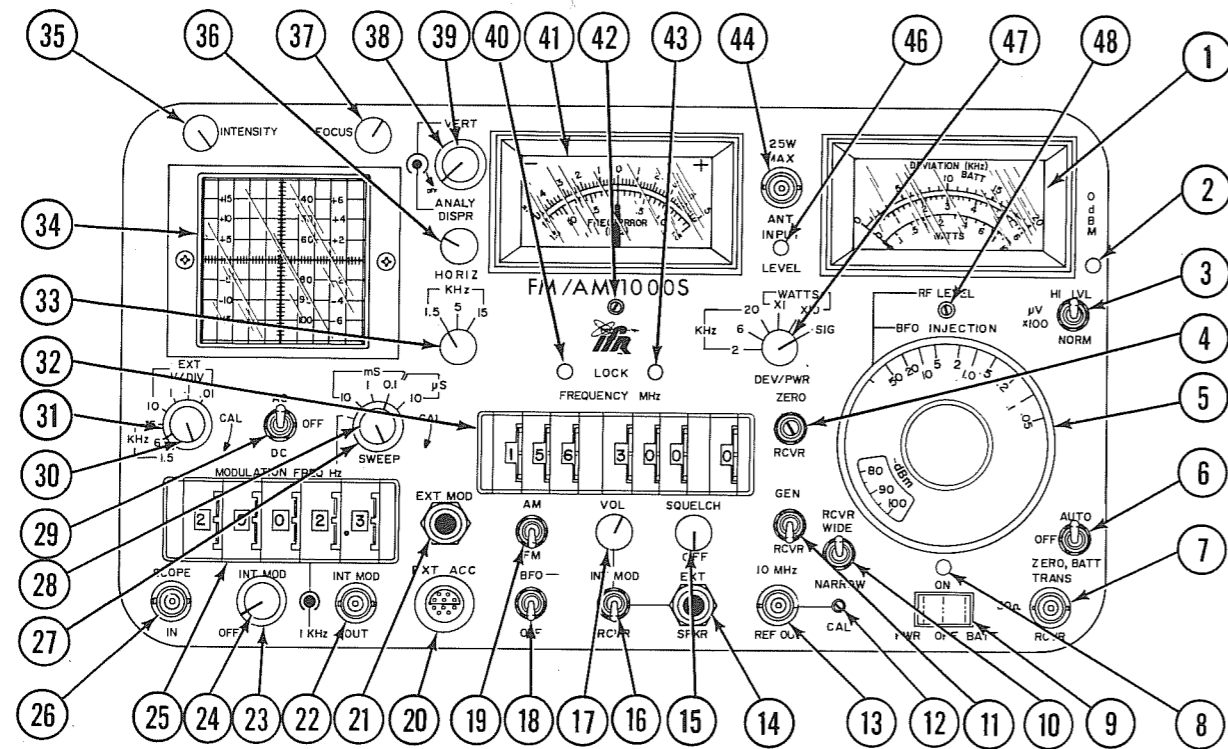

FIGURE 3-1 FM/AM-1000S FRONT PANEL

- |    |                                   |    |                                       |
|----|-----------------------------------|----|---------------------------------------|
| 1  | DEVIATION/WATTS Meter             | 26 | SCOPE IN Connector                    |
| 2  | 0 dBm Lamp                        | 27 | SWEEP Control                         |
| 3  | HI LVL/ $\mu$ V X 100/NORM Switch | 28 | SWEEP Vernier Control                 |
| 4  | ZERO RCVR Adjustment              | 29 | AC/OFF/DC Switch                      |
| 5  | RF LEVEL/BFO INJECTION Dial       | 30 | EXT V/DIV Vernier Control             |
| 6  | AUTO/OFF/ZERO, BATT Switch        | 31 | EXT V/DIV Control                     |
| 7  | TRANS/RCVR Connector              | 32 | FREQUENCY MHz Thumbwheels             |
| 8  | Power ON Lamp                     | 33 | 1.5/5/15 kHz Control                  |
| 9  | PWR/OFF/BATT Switch               | 34 | CRT Display                           |
| 10 | RCVR WIDE/MID/NARROW Switch       | 35 | INTENSITY Control                     |
| 11 | GEN/RCVR Switch                   | 36 | HORIZ Control                         |
| 12 | 10 MHz CAL Adjustment             | 37 | FOCUS Control                         |
| 13 | 10 MHz REF OUT Connector          | 38 | VERT Control                          |
| 14 | EXT SPKR Connector                | 39 | ANALY DISPR Control                   |
| 15 | SQUELCH Control                   | 40 | High Frequency LOCK Lamp              |
| 16 | INT MOD/RCVR Switch               | 41 | FREQ ERROR Meter                      |
| 17 | VOL Control                       | 42 | FREQ ERROR Meter Zero Adjustment      |
| 18 | BFO/OFF Switch                    | 43 | Low Frequency LOCK Lamp               |
| 19 | AM/FM Switch                      | 44 | ANT INPUT Connector                   |
| 20 | EXT ACC Connector                 | 45 | NOT USED                              |
| 21 | EXT MOD Connector                 |    |                                       |
| 22 | INT MOD OUT Connector             | 46 | INPUT LEVEL Lamp                      |
| 23 | INT MOD Control                   | 47 | DEV/PWR Control                       |
| 24 | 1 kHz INT MOD Control             | 48 | DEVIATION/WATTS Meter Zero Adjustment |
| 25 | MODULATION FREQ Hz Thumbwheels    |    |                                       |

- | Item | Name  | Description  |
|------|---|--|
| 1.   | <u>DEVIATION/WATTS Meter</u>                      | Provides visual display of peak FM deviation, transmitter output power, transmitter signal strength (as received at ANT INPUT Connector (44)) and internal battery charge condition.   |
| 2.   | <u>0 dBm LAMP</u>                                 | Illuminates when FM/AM-1000S RF signal output is at 0 dBm or above.  |
| 3.   | <u>HI LVL/<math>\mu</math>V X 100/NORM Switch</u> | Three-position switch which selects power range for RF LEVEL/BFO INJECTION Dial (5) as follows:<br><br>"NORMAL" position - RF/BFO output level is equal to setting of RF LEVEL/BFO INJECTION Dial (5) on " $\mu$ V" or "dBm" scale.<br><br>" $\mu$ V X 100" position - RF/BFO output level is 100 times the RF LEVEL/BFO INJECTION Dial (5) setting on the " $\mu$ V" scale. (Equivalent level in dBm is equal to reading of dBm scale, plus 40 dB.)<br><br>"HIGH LEVEL" position - Enables RF output levels above -35 dBm to be achieved. |
| 4.   | <u>ZERO RCVR Adjustment</u>                       | Adjustment screw for zeroing FREQ ERROR Meter (41) when FM/AM-1000S power is "ON." (GEN/RCVR Switch (11) must be in "GEN" position when zeroing meter.)  |
| 5.   | <u>RF LEVEL/BFO INJECTION Dial</u>                | Controls FM/AM-1000S RF output level when set is operating in signal generator mode and BFO (beat frequency oscillator) injection level when set is operating in receiver mode. Control knob contains scales for reading power levels in both " $\mu$ V" (microvolts) and "dBm" (decibels per milliwatt).  |
| 6.   | <u>AUTO/OFF/ZERO, BATT Switch</u>                 | Three-position switch which activates/deactivates auto-zeroing circuit and provides a visual indication of internal battery voltage condition as follows:<br><br>"AUTO" position - Auto-zeroing circuit is activated, automatically zeroing receiver and FREQ ERROR Meter (41) through an internal self-check.<br><br>"OFF" position - Auto-zeroing circuit is deactivated.  |

Item	Name	Description
------	------	-------------

6. AUTO/OFF/ZERO, BATT Switch (cont'd)

"BATT" position - When switch is held in this springloaded position, a visual indication of internal battery voltage condition is displayed on DEVIATION/WATTS Meter (1). Battery is discharged when DEVIATION/WATTS Meter (1) reads 11 volts under load; FM/AM-1000S will turn off automatically when this condition occurs.

**NOTE**

- When activated, auto-zeroing reference pulse will cause minor CRT trace and meter needle deflections to occur; this is a normal operating condition and should be disregarded.
- With auto-zeroing circuit activated, a 3 ms void will be produced by reference pulse every 1.5 seconds in generate/receive modes. If this condition hinders testing of UUT (Unit Under Test), place switch to "OFF" position. In "OFF" position, FREQ ERROR Meter (41) is not calibrated and should not be used for frequency error measurements.

7. TRANS/RCVR Connector

50 RF input/output connector for UUT.

**CAUTION**

- DO NOT APPLY MORE THAN 20 WATTS OF CONTINUOUS INPUT TO TRANS/RCVR CONNECTOR. Maximum "ON" time for measurement of transmitter output using TRANS/RCVR Connector is:

10 seconds at 100 W, 15% Duty Cycle  
 20 seconds at 50 W, 30% Duty Cycle  
 2 minutes at 30 W, 50% Duty Cycle

8. Power ON Lamp

Illuminates when power is applied to FM/AM-1000S.

9. PWR/OFF/BATT Switch

Three-position rocker switch which supplies/interrupts power to FM/AM-1000S as follows:

"PWR" (Leftmost position) - Applies external AC or DC power to FM/AM-1000S.

Item	Name	Description
9.	<u>PWR/OFF/BATT Switch</u> (cont'd)	
	"OFF" (Center position)	- Shuts off power to all FM/AM-1000S circuits, except battery charger circuit.
	"BATT" (Rightmost position)	- Powers FM/AM-1000S by its internal battery set will turn off automatically after approximately eight minutes of operation, to prevent battery rundown.
<b>NOTE</b>		
	●	FM/AM-1000S internal battery is charged whenever set is connected to an AC power source, including when power switch is "OFF."
10.	<u>RCVR WIDE/MID/NARROW Switch</u>	Selects "WIDE", "MID" or "NARROW" bandwidth of FM/AM-1000S receiver.
11.	<u>GEN/RCVR Switch</u>	Controls operating mode of FM/AM-1000S as a signal generator or receiver as follows:
	"GEN" position	- FM/AM-1000S functions as a signal generator, producing RF output at TRANS/RCVR Connector (7). If RF energy is applied to this connector (7) while set is in generator mode, set will automatically switch to receiver mode.
	"RCVR" position	- FM/AM-1000S functions as a receiver. Signal input (0.1 watt minimum required) may be direct through the TRANS/RCVR Connector (7) or "off-the-air" via an external antenna attached to ANT INPUT Connector (44).
12.	<u>10 MHZ CAL Adjustment</u>	Fine tuning adjustment for FM/AM-1000S 10 MHz master oscillator frequency.
13.	<u>10 MHz REF OUT Connector</u>	10 MHz master oscillator output connector.
14.	<u>EXT SPKR Connector</u>	Audio output connector for remote speaker, headphones etc.

Item	Name	Description
15.	<u>SQUELCH Control</u>	Squelch threshold adjustment; squelch disables audio output when RF input at ANT INPUT Connector (44) falls below squelch threshold.
		<b>NOTE</b>
		● SQUELCH Control is "OFF" when fully ccw in detent position. When out of detent position, rotate control cw to increase squelch threshold or ccw to decrease threshold. (The greater the squelch threshold, the greater the signal input required to break the threshold.)
16.	<u>INT MOD/RCVR Switch</u>	Couples FM/AM-1000S receiver or dual tone generator audio output to FM/AM-1000S internal speaker.
17.	<u>VOL Control</u>	Controls audio output level of FM/AM-1000S internal speaker (or external accessory speaker when connected to EXT SPKR Connector (14)).
18.	<u>BFO/OFF Switch</u>	Activates or deactivates FM/AM-1000S internal beat frequency oscillator (BFO).
19.	<u>AM/FM Switch</u>	Selects signal mode to be generated or received by FM/AM-1000S as follows: <p style="margin-left: 40px;">"AM" position - FM/AM-1000S generates or receives amplitude modulated (AM) signals.</p> <p style="margin-left: 40px;">"FM" position - FM/AM-1000S generates or receives frequency modulated (FM) signals.</p>
20.	<u>EXT ACC Connector</u>	Output connector providing power or signal sources for external accessory equipment. (See Appendix F for connector pin assignments.)
21.	<u>EXT MOD Connector</u>	Input connector for external modulation sources. (See Appendix F for connector contact assignments.)
22.	<u>INT MOD OUT Connector</u>	Output connector which couples dual tone generator audio output to external devices. Output level is controlled by INT MOD Control (23) and 1 kHz INT MOD Control (24).

Item	Name	Description
------	------	-------------

22. INT MOD OUT Connector (cont'd)

**NOTE**

- Output can consist of one or any combination of following modulated signals mixed together:

1 kHz INTERNAL MODULATION  
VARIABLE INTERNAL MODULATION  
EXTERNAL MODULATION

23. INT MOD Control

Controls %AM modulation or FM peak deviation of frequency selected on MODULATION FREQ Hz Thumbwheels (25). Modulation control is "OFF" in full ccw, detent position; when out of detent, rotate control cw to increase modulation level.

**NOTE**

- Modulated frequency can be externally keyed through the EXT MOD Connector (21).

24. 1 kHz INT MOD Control

Controls %AM modulation or FM peak deviation for an approximate 1 kHz tone. Modulation control is "OFF" in full ccw detent position; when out of detent, rotate control cw to increase modulation level.

25. MODULATION FREQ Hz Thumbwheels

Select internal modulation frequency produced by dual tone generator (10.0 Hz through 9999.9 Hz).

26. SCOPE IN Connector

Vertical deflection input for oscilloscope.

**CAUTION**

- DO NOT APPLY MORE THAN 200 VOLTS (PEAK-TO-PEAK) TO THIS CONNECTOR.

27. SWEEP Control

Controls horizontal sweep speed of oscilloscope in indicated millisecond or microsecond increments per graticule division.

28. SWEEP Vernier Control

Permits continuous variation of sweep speed within any of the ranges provided by SWEEP Control (27). In "CAL" position (fully cw, detent), oscilloscope horizontal graticule divisions are equal to setting of SWEEP Control.

Item	Name	Description
------	------	-------------

28. SWEEP Vernier Control (cont'd)

**NOTE**

- Do not make time measurements with SWEEP Vernier Control out of "CAL" position.

29. AC/OFF/DC Switch

Three-position switch which AC couples scope inputs in "AC" position, DC couples scope inputs in "DC" position and disconnects power from oscilloscope/spectrum analyzer in "OFF" position.

**NOTE**

- When switching from one coupling mode to another, pause briefly in "OFF" position; this ensures that scope power supply inverter will start.
- To conserve power during battery operation, place coupling switch to "OFF" when oscilloscope or spectrum analyzer are not in use.

30. EXT V/DIV Vernier Control

Permits variation of oscilloscope vertical sensitivity within any of the ranges provided by EXT V/DIV Control (31). In "CAL" position (fully cw detent), oscilloscope vertical graticule divisions are equal to setting of EXT V/DIV Control (31).

**NOTE**

- Do not make voltage measurements with EXT V/DIV Vernier Control out of "CAL" position.

31. EXT V/DIV Control

Controls oscilloscope vertical sensitivity and input source applied to oscilloscope as follows:

"EXT V/DIV" positions - Selects oscilloscope vertical sensitivity (in indicated voltage increments per graticule division) for signals applied to SCOPE IN Connector (26).

"kHz" positions - Oscilloscope displays frequency deviation (in "FM" mode) or modulation envelope (in "AM" mode).



Item	Name	Description
------	------	-------------

31. EXT V/DIV Control (cont'd)

EXAMPLE: (Reference CRT display below.)  
 If EXT V/DIV Switch is positioned to 15 or 1.5 kHz setting, measured full scale frequency deviation is 15 kHz or 1.5 kHz along scale "A." If switch is positioned to 6 kHz setting, measured full scale frequency deviation is 6 kHz along scale "B".

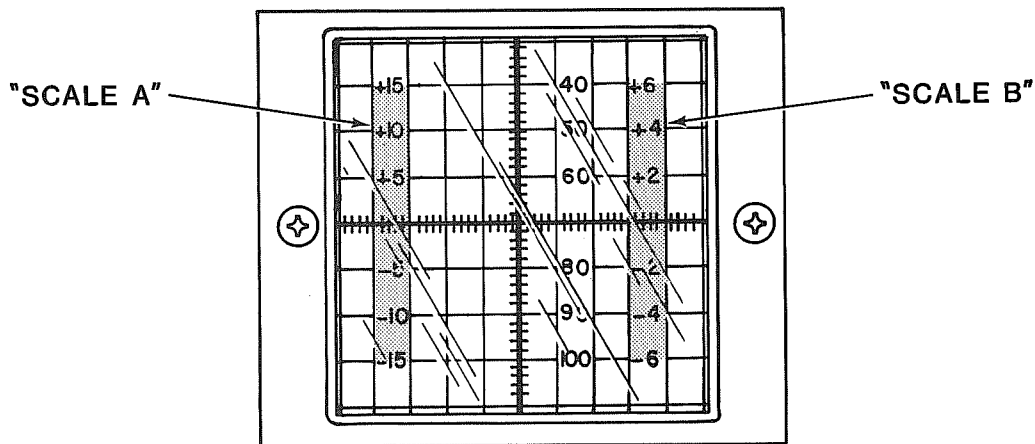

FIGURE 3-2 CRT DISPLAY DEVIATION SCALES

**NOTE**

- When viewing modulation envelope in "AM" mode, setting of EXT V/DIV Control in "kHz" range is irrelevant.

32. FREQUENCY Hz Thumbwheels

Select signal generator or receiver frequency.

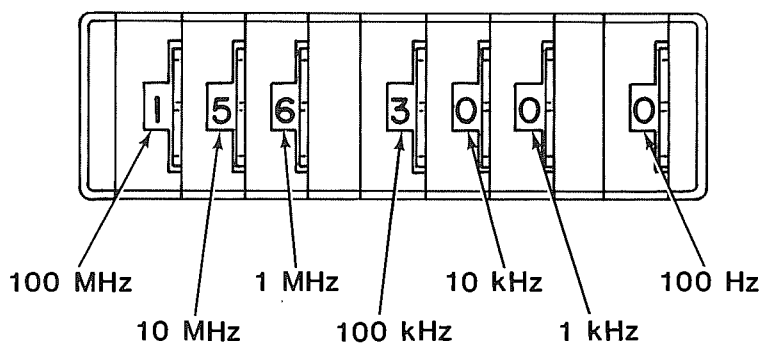

FIGURE 3-3 FREQUENCY MHz THUMBWHEELS

Item	Name	Description
33.	<u>1.5/5/15 kHz Control</u>	Selects full scale sensitivity of "FREQUENCY ERROR METER" (41).
34.	<u>CRT Display</u>	Display screen for FM/AM-1000S oscilloscope or spectrum analyzer.

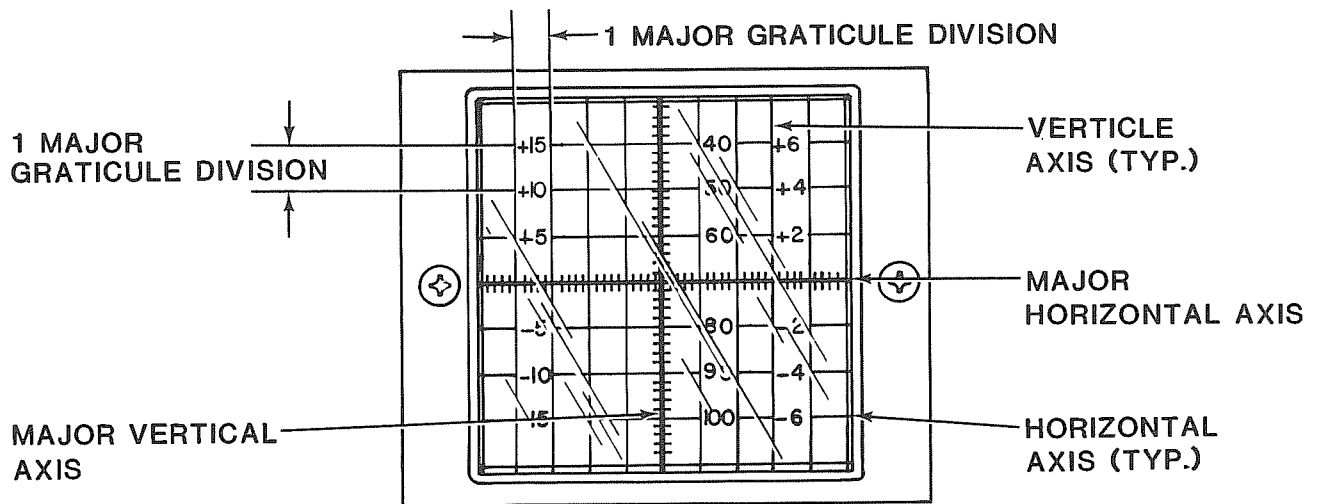

FIGURE 3-4 CRT DISPLAY GRATICULE MARKINGS

35. INTENSITY Control  
Controls brightness of CRT trace. Rotate control ccw to decrease brightness, cw to increase brightness.

**CAUTION**

- When applying power to oscilloscope or spectrum analyzer through PWR/OFF/BATT Switch (9) or AC/OFF/DC Switch (29), make sure INTENSITY Control (35) is turned to a moderate intensity level.
- Warm-up time of CRT is approximately 30 seconds from a "cold" start-up; trace display will not become visible until CRT achieves warm-up.

36. HORIZ Control  
Controls horizontal position of oscilloscope trace. Rotate control cw to move trace to right, ccw to move trace to left.
37. FOCUS Control  
Controls sharpness of oscilloscope trace.

Item	Name	Description
38.	<u>VERT Control</u>	Controls vertical position of oscilloscope trace. Rotate control cw to move trace up, ccw to move trace down.
39.	<u>ANALY DISPR Control</u>	Continuously varies spectrum analyzer dispersion within a span of 1 to 10 MHz. Full cw rotation of control provides a dispersion of 1 MHz per major graticule division; full ccw rotation (short of detent position) provides a dispersion of 0.1 MHz per major graticule division. In full ccw detent position, spectrum analyzer is "OFF" and oscilloscope is "ON."
<b>NOTE</b>		
<ul style="list-style-type: none"> <li>● During spectrum analyzer operation, all oscilloscope controls except INTENSITY Control (35), FOCUS Control (37) and AC/OFF/DC Switch (29) are disabled. Spectrum Analyzer can be turned "OFF" using AC/OFF/DC Switch (29).</li> </ul>		
40.	<u>High Frequency Phase LOCK Light</u>	When illuminated, indicates proper operation of High Frequency Phase Lock Board in FM/AM-1000S. Light will "blink" momentarily when "MHz" segments of FREQUENCY MHz Thumbwheels (32) are incremented or decremented, however light should remain illuminated at all other times when FM/AM-1000S power is "ON."
41.	<u>FREQ ERROR Meter</u>	Provides visual display of difference between received signal frequency and FM/AM-1000S receiver frequency (as represented by FREQUENCY MHz Thumbwheel (32) setting).
42.	<u>FREQ ERROR Meter Zero Adjustment</u>	Mechanical zero adjustment of FREQ ERROR Meter (41) intended for use when power to FM/AM-1000S is "OFF."
43.	<u>Low Frequency Phase LOCK Light</u>	When illuminated, indicates proper operation of 79-80 MHz Low Frequency Phase Lock Board in FM/AM-1000S. Light will "blink" momentarily when "kHz" and "Hz" segments of FREQUENCY MHz Thumbwheels (32) are incremented or decremented, however light should remain illuminated at all other times when FM/AM-1000S power is "ON."
44.	<u>ANT INPUT CONNECTOR</u>	External antenna input to FM/AM-1000S, used primarily for "off-the-air" testing.

Item	Name	Description
44.	<u>ANT INPUT Connector</u> (cont'd)	
		<b>CAUTION</b>
		<ul style="list-style-type: none"> <li>● MAXIMUM CONTINUOUS INPUT ANT INPUT CONNECTOR MUST NOT EXCEED .25 W.</li> <li>● MAXIMUM INPUT TO ANT INPUT CONNECTOR IS -30 dBm FOR PROPER SPECTRUM ANALYZER OPERATION. (Signals above -30 dBm may cause spurious signals to be generated and displayed by FM/AM-1000S.)</li> <li>● IF AN EXTERNAL ANTENNA ATTACHED TO AN UNTERMINATED COAX CABLE IS USED, REMOVE ANY POSSIBLE STATIC CHARGE FROM ANTENNA COAX BEFORE CONNECTING TO FM/AM-1000S.</li> </ul>
45.	NOT USED	
46.	<u>INPUT LEVEL Lamp</u>	When illuminated, indicates input level at ANT INPUT Connector (44) is above squelch threshold of FM/AM-1000S receiver.
47.	<u>DEV/PWR Control</u>	Selects ranges for peak FM frequency deviation, input power at TRANS/RCVR Connector (7) and received signal strength as follows: <ul style="list-style-type: none"> <li>"kHz" positions - Selects full scale range for peak FM deviation as displayed by DEVIATION/WATTS Meter (1).</li> <li>"WATTS" positions - Selects multiplier for output power measurements on red "WATTS" scale of DEVIATION/WATTS Meter (1).</li> <li>"SIG" position - For signals received "off-the-air", a qualitative representation of relative signal strength can be determined by observing DEVIATION/WATTS Meter (1) needle deflection. As signal strength increases, the meter needle deflection will increase towards right of meter scale.</li> </ul>
48.	<u>DEVIATION/WATTS Meter Zero Adjustment</u>	Mechanical zero adjustment of DEVIATION/WATTS Meter intended for use when FM/AM-1000S power is "OFF."

## SECTION 3 - DESCRIPTION OF CONTROLS, CONNECTORS & INDICATORS

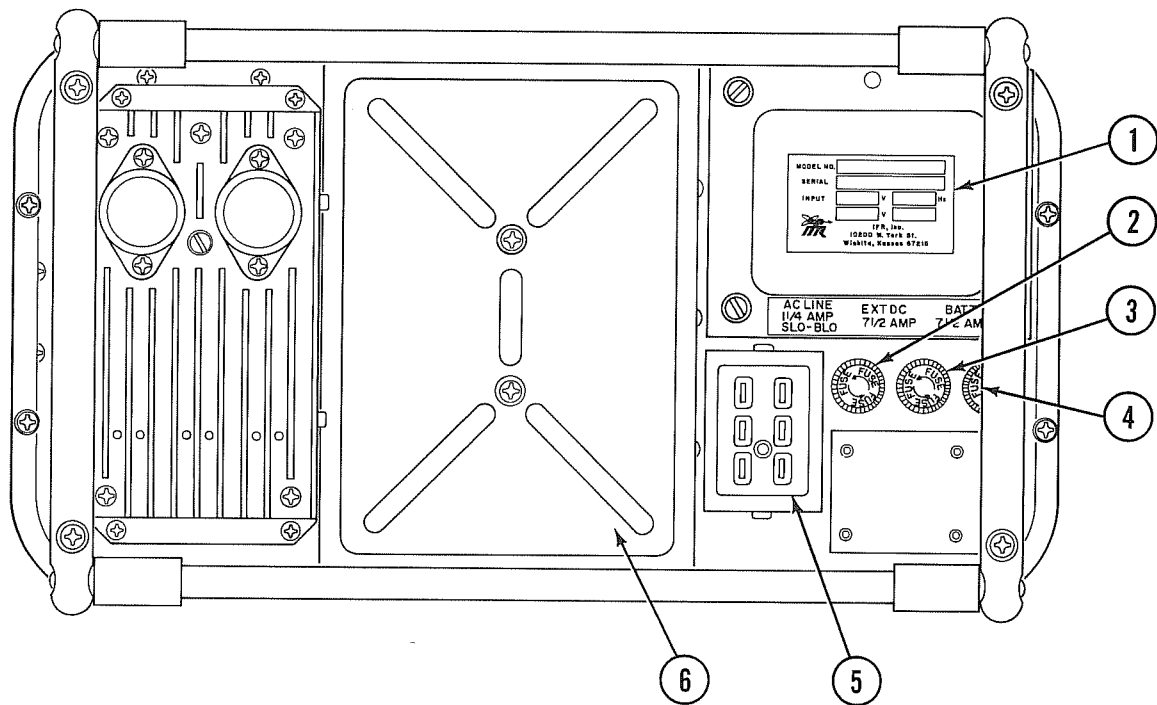

FIGURE 3-5 FM/AM-1000S REAR PANEL

ITEM	NAME	DESCRIPTION
1.	SERIAL NO. NAMEPLATE	
2.	AC LINE FUSE	1½ Amp. SLO BLO fuse.
3.	EXTERNAL DC FUSE	7½ Amp. fuse.
4.	BATTERY FUSE	7½ Amp. fuse.
5.	6-PIN EXTERNAL POWER RECEPTACLE	
6.	BATTERY HOUSING	

# SECTION 4 - OPERATION

## 4-1 GENERAL

This section contains operating instructions relating to all major functions of the FM/AM-1000S and is divided into the following two major subsections:

### BASIC FUNCTIONAL OPERATING PROCEDURES

<u>Section</u>	<u>Title</u>
4-2	Test Procedures Using FM/AM-1000S Oscilloscope
4-3	Test Procedures Using FM/AM-1000S Spectrum Analyzer
4-4	Test Procedures Using FM/AM-1000S Dual Tone Generator
4-5	Test Procedures Using FM/AM-1000S RF Generator
4-6	Test Procedures Using FM/AM-1000S Receiver
4-7	Test Procedures Using FM/AM-1000S as a Sweep Generator/Tracking Oscilloscope.

### GENERAL RECEIVER/TRANSMITTER TESTS

<u>Section</u>	<u>Title</u>
4-8	General Receiver Tests
4-9	General Transmitter Tests

For purposes of clarity and ease of understanding, all instructions are presented as individual test procedures conforming to a "step by step" format. The procedures included within each section are those most commonly associated with the various functions of the FM/AM-1000S and AM/FM transceiver testing.

Each group of "BASIC FUNCTIONAL OPERATING PROCEDURES" is preceded by a brief introductory paragraph relating to the particular FM/AM-1000S function to be used, followed by a table containing FM/AM-1000S initial control settings required for use of that function. Each individual test procedure in turn (including those under "GENERAL RECEIVER/TRANSMITTER TESTS"), contains the following common headings:

4-2-1	Test procedure number.
TEST PROCEDURE:	Name of procedure to be performed.
TEST OBJECTIVE:	Purpose or intent of procedure; if name of "TEST PROCEDURE" itself implies test objective, this heading will contain N/A (not applicable).
SPECIAL ACCESSORY EQUIPMENT REQ'D:	List of any special accessory test equipment required to complete procedure, beyond FM/AM-1000S and UUT.
TEST SET-UP DIAGRAM:	A diagrammatic aid to operator in making proper connections between FM/AM-1000S, UUT and special accessory equipment.

## 4-1 GENERAL (CONT'D)

### NOTE

**MM-100**

Those procedures bearing the the symbol **MM-100** on the upper right hand corner of the page, can be more easily performed using the MM-100 Multi-Meter option. If your FM/AM-1000S is so equipped, refer to MM-100 Operation Manual for the corresponding procedure.

### 4-1-1 PRE-OPERATIONAL CONSIDERATIONS

For maximum benefit of all operating procedures contained herein, it is strongly recommended that operator:

1. Thoroughly read and understand all steps of procedure to be performed, prior to its completion.
2. Be familiar with the circuit or unit under test so some idea is perceived as to the voltage, frequency and waveform to be expected at each test point. This knowledge will aid operator in performing the test procedure in a logical efficient manner with a minimum of blind searching.

### 4-1-2 OPERATING PRECAUTIONS

In addition to the general safety precautions listed under Section 2-1-1 of this manual, the operator must observe the following additional operating precautions:

1. When working with "live" circuits of high potential, keep one hand in pocket or behind back to avoid serious shock hazard.
2. Remove all jewelry or other cosmetic apparel before performing any test procedures involving "live" circuits.
3. Use only insulated troubleshooting tools when working with "live" circuits.
4. For added insulation, place rubber bench mat underneath all powered bench equipment, as well as a rubber floor mat underneath operator chair.
5. Heed all WARNINGS and CAUTIONS concerning maximum voltage and power inputs.
6. Avoid using oscilloscope/spectrum analyzer in direct sunlight, as scope trace is difficult to see under these conditions.
7. Do not allow scope trace to become concentrated on CRT as a stationary spot, as CRT screen may be burned permanently. Reduce trace intensity if trace must remain stationary.
8. Protect FM/AM-1000S from vibration or mechanical shock. The CRT of the FM/AM-1000S is highly evacuated and if broken, will implode causing possible serious injury from fragmented glass.

---

## **4-2 TEST PROCEDURES USING FM/AM-1000S OSCILLOSCOPE**



#### **4-2-1 GENERAL**

The FM/AM-1000S contains a 1 MHz oscilloscope designed for use as a general purpose diagnostic tool. The operator can use this instrument to observe or measure such signal characteristics as AC/DC voltage level, waveshape, pulse duration, pulse spacing and frequency. Additional features unique to this oscilloscope include the selectability of two sweep sources (internal saw-tooth generator and dual tone generator) and the ability to monitor both AM and FM signal modulation.

The procedures contained in this section are:

- 4-2-3 MEASURING DC VOLTAGES
- 4-2-4 MEASURING PEAK-TO-PEAK VOLTAGES
- 4-2-5 MEASURING RMS AC VOLTAGES (Sine Wave Only)
- 4-2-6 MEASURING PEAK AC VOLTAGES
- 4-2-7 MEASURING FREQUENCIES BETWEEN 5 kHz AND 500 kHz
- 4-2-8 MEASURING PULSE DURATION AND DUTY CYCLE

## 4-2-2 INITIAL FM/AM-1000S CONTROL SETTINGS FOR OSCILLOSCOPE OPERATION

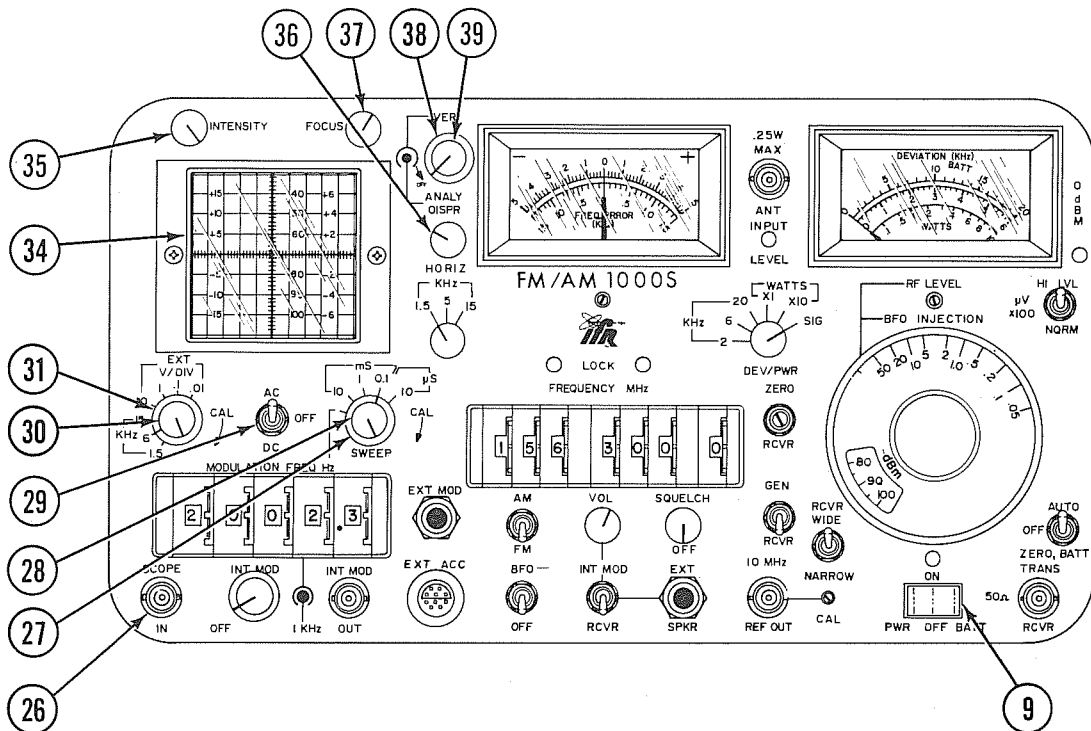

FIGURE 4-1 FM/AM-1000S CONTROLS APPLICABLE TO OSCILLOSCOPE OPERATION

(Refer to "SECTION 3 - DESCRIPTION OF CONTROLS, CONNECTORS & INDICATORS" for functional description of any controls used in this section.)

### NOTE

- Before performing any procedures contained in this section pertaining to oscilloscope operation, make sure all applicable test set controls are positioned as outlined below.
- Some of the control settings outlined below may be changed during the course of a given procedure; all controls, however, should be reset to initial positions described below when starting a new procedure.

CONTROL	INITIAL SETTING	
9	PWR/OFF/BATT Switch	"OFF" position
27	SWEEP Control	"1ms" position
28	SWEEP Vernier Control	Fully cw, detent (in "CAL" position)
29	AC/OFF/DC Switch	"DC" position
30	EXT V/DIV Vernier Control	Fully cw, detent (in "CAL" position)
31	EXT V/DIV Control	"10 V/DIV" position
35	INTENSITY Control	Midrange position
36	HORIZ Control	Midrange position

#### 4-2-2 INITIAL FM/AM-1000S CONTROL SETTINGS FOR OSCILLOSCOPE OPERATION (CONT'D)

CONTROL	INITIAL SETTING
37 FOCUS Control	Midrange position
38 VERT Control	Midrange position
39 ANALY DISPR Control	Fully ccw, detent

Other FM/AM-1000S features related to oscilloscope operation but not requiring an initial setting:

- 26 SCOPE IN Connector
- 34 CRT Display

The FM/AM-1000S is now ready for oscilloscope operation.

### 4-2-3

TEST PROCEDURE: **MEASURING DC VOLTAGES**

TEST OBJECTIVE: N/A

SPECIAL ACCESSORY  
EQUIPMENT REQ'D: N/A

TEST SET-UP  
DIAGRAM: N/A

- | STEP | PROCEDURE  |
|------|--|
| 1.   | Set FM/AM-1000S controls for general oscilloscope operation as shown in Figure 4-1, page 4-5.                  |
| 2.   | Apply power to FM/AM-1000S.  |
| 3.   | Apply power to UUT.  |
| 4.   | Adjust INTENSITY Control (35) cw and FOCUS Control (37) appropriately to obtain a sharp visible trace display. |

#### **NOTE**

- Warm-up time of CRT is approximately 30 seconds from a "cold" start-up; trace display will not become visible until CRT achieves warm-up.
5. Adjust VERTICAL Control (38) and HORIZ Control (36) to center scope trace over major horizontal axis of CRT.

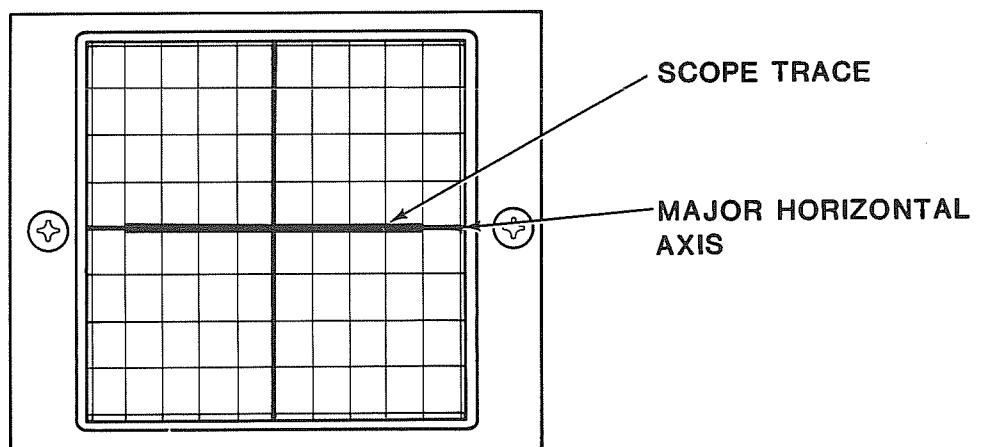

**FIGURE 4-2 SCOPE TRACE CENTERED OVER MAJOR HORIZONTAL AXIS**

## STEP

## PROCEDURE

6. Apply signal to be measured to SCOPE IN Connector (26) using a scope probe or coax. If a scope probe is used, make sure ground lead is attached to UUT ground.

**CAUTION**

- DO NOT APPLY MORE THAN 200 VOLTS (PEAK-TO-PEAK) TO SCOPE IN CONNECTOR (26).

7. Observe trace deflection in relation to major horizontal axis to which trace was previously aligned:

- If trace deflection is downward (towards bottom of CRT), voltage being measured is negative.
- If trace deflection is upward (towards top of graticule), voltage being measured is positive.

8. To determine voltage of signal:

- Count and record number of graticule divisions (along major vertical axis) from major horizontal axis to location where trace is now deflected (see examples below):

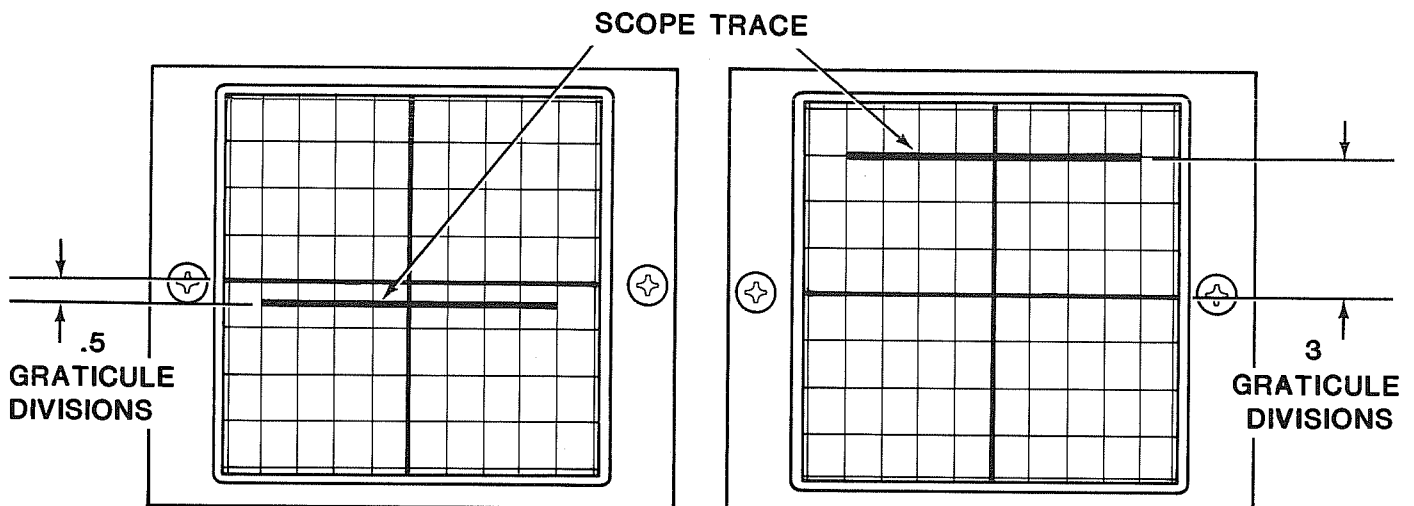

FIGURE 4-3 EXAMPLES OF DC VOLTAGE MEASUREMENTS

**NOTE**

- If trace deflection from major horizontal axis is too small to be accurately measured, adjust EXT V/DIV Control to next smaller volts/division setting. This should result in a greater trace deflection.

STEP

PROCEDURE

8. (cont'd)

- b. Multiply result obtained in Step 8a by setting of EXT V/DIV Control (31):

Trace deflection in graticule divisions  $\times$  Setting of EXT V/DIV Control = DC VOLTAGE

EXAMPLE: Trace deflection = 2.6 graticule divisions

EXT V/DIV  
Control Setting = .1 volts/division

$$(2.6) \times (.1) = .26 \text{ volts DC}$$



#### 4-2-4

TEST PROCEDURE: **MEASURING PEAK TO PEAK VOLTAGES**

TEST OBJECTIVE: N/A

SPECIAL ACCESSORY  
EQUIPMENT REQ'D: N/A

TEST SET-UP  
DIAGRAM: N/A

- | STEP | PROCEDURE  |
|------|--|
| 1.   | Set FM/AM-1000S controls for oscilloscope operation as shown in Figure 4-1, page 4-5.                          |
| 2.   | Place scope AC/OFF/DC Switch (29) to "AC" position.  |
| 3.   | Apply power to FM/AM-1000S.  |
| 4.   | Apply power to UUT.  |
| 5.   | Adjust INTENSITY Control (35) cw and FOCUS Control (37) appropriately to obtain a sharp visible trace display. |

#### **NOTE**

- Warm-up time of CRT is approximately 30 seconds from a "cold" start-up; trace display will not become visible until CRT achieves warm-up.
- |    |  |
|----|--|
| 6. | Adjust VERT Control (38) and HORIZ Control (36) to center scope trace over major horizontal axis of CRT.   |
| 7. | Apply signal to be measured to SCOPE IN Connector (26) using a scope probe or coax. If a scope probe is used, make sure ground lead is attached to UUT ground. |

#### **CAUTION**

- DO NOT APPLY MORE THAN 200 VOLTS (PEAK-TO-PEAK) TO SCOPE IN CONNECTOR (26).
- |    |  |
|----|--|
| 8. | Adjust SWEEP Control (27), EXT V/DIV Control (31) and SWEEP Vernier Control (28) to obtain a stable waveform display of signal to be measured. |
|----|--|



STEP

PROCEDURE

8. (cont'd)

**NOTE**

- EXT V/DIV Vernier Control(30) must remain in "CAL" position (fully cw, detent).

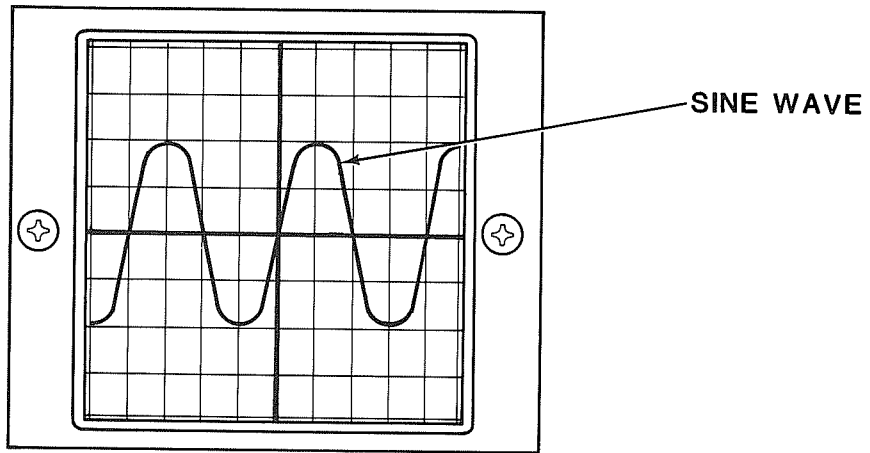

FIGURE 4-4 STABLE SINE WAVE DISPLAY

9. Adjust VERT Control (38) until negative peaks of waveform rest on any horizontal axis of scope display.

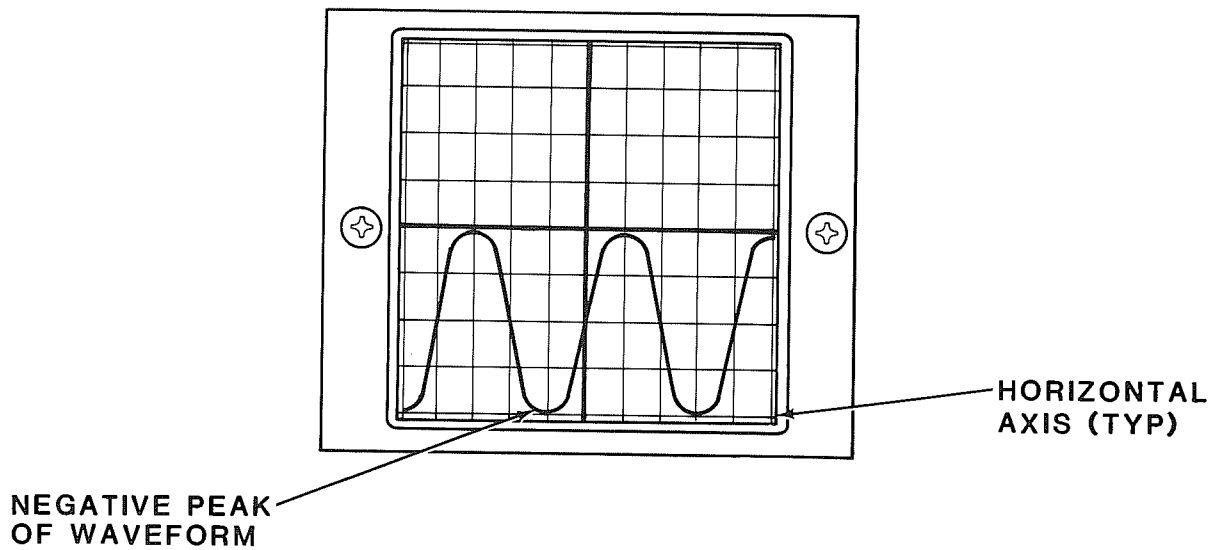

FIGURE 4-5 NEGATIVE PEAKS OF SINE WAVE RESTING ON HORIZONTAL AXIS

STEP

PROCEDURE

10. Adjust HORIZ Control (36) to center positive peak of waveform over major vertical axis of CRT.

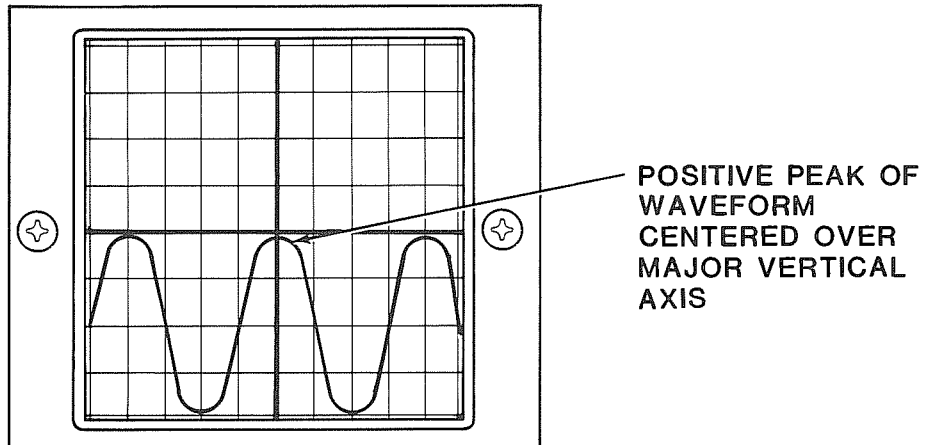

FIGURE 4-6 POSITIVE PEAK OF WAVEFORM CENTERED OVER MAJOR VERTICAL AXIS

11. Count number of graticule divisions between positive and negative peaks of waveform. Record this number.

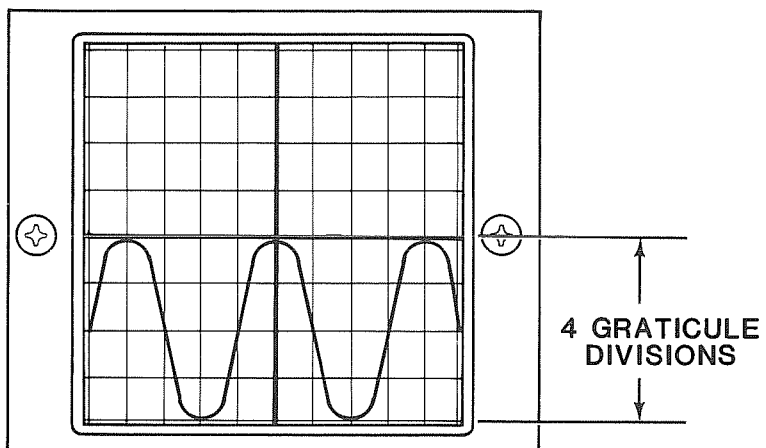

FIGURE 4-7 MEASURING PEAK-TO-PEAK AMPLITUDE OF WAVEFORM

12. Multiply result obtained in Step 9 by setting of EXT V/DIV Control (31):

No. of graticule divisions from negative to positive peak	X	Setting of EXT V/DIV Control	PEAK-TO- = PEAK . VOLTAGE
---	---	---------------------------------	---------------------------------

STEP

PROCEDURE

12. (cont'd)

EXAMPLE: Graticule divisions from positive to negative  
peaks: 4.5

EXT V/DIV Control  
Setting = 1 VOLT/DIVISION

$(4.5) \times (1) = 4.5$  VOLTS PEAK-TO-PEAK

#### 4-2-4

TEST PROCEDURE: **MEASURING RMS AC VOLTAGES (SINE WAVE ONLY)**

TEST OBJECTIVE: N/A

SPECIAL ACCESSORY  
EQUIPMENT REQ'D: N/A

TEST SET-UP  
DIAGRAM: N/A

- | STEP | PROCEDURE   |
|------|---|
| 1.   | Perform procedure 4-2-4, titled "HOW TO MEASURE PEAK-TO-PEAK VOLTAGES", on page 4-11. |
| 2.   | Apply resultant peak-to-peak voltage to following equation:                           |

$$\text{VOLTS RMS} = \frac{V_{p-p}}{2} \times 0.707$$

EXAMPLE:

Peak-to-peak voltage obtained in Step 1 = 6.8 Volts

$$\text{VOLTS RMS} = \frac{6.8}{2} \times 0.707$$

$$\text{VOLTS RMS} = 3.4 \times 0.707$$

$$\text{VOLTS RMS} = 2.4038$$



**4-2-6**

TEST PROCEDURE: **MEASURING PEAK AC VOLTAGES**

TEST OBJECTIVE: N/A

SPECIAL ACCESSORY  
EQUIPMENT REQ'D: N/A

TEST SET-UP  
DIAGRAM: N/A

STEP	PROCEDURE
1.	Perform procedure 4-2-4, titled "HOW TO MEASURE PEAK-TO-PEAK VOLTAGES", on page 4-11.
2.	Divide resultant peak-to-peak voltage by two. The result of this step is the peak voltage ( $V_p$ ).



## 4-2-7

### TEST PROCEDURE: **MEASURING FREQUENCIES BETWEEN 5 Hz AND 500 kHz\***

(\* The frequency response of the FM/AM-1000's oscilloscope is 1 MHz. However, due to the resolution of the scope trace and the limitations of the sweep range, 500 kHz is the largest practical frequency that can be measured under this procedure.)

TEST OBJECTIVE: N/A

SPECIAL ACCESSORY  
EQUIPMENT REQ'D: Calculator

TEST SET-UP  
DIAGRAM: N/A

- | STEP        | PROCEDURE  |
|-------------|--|
| 1.          | Set FM/AM-1000S controls for general oscilloscope operation as shown in Figure 4-1, page 4-5.  |
| 2.          | Place AC/OFF/DC Switch (29) to "AC" position.  |
| 3.          | Apply power to UUT.  |
| 4.          | Apply power to FM/AM-1000S.  |
| 5.          | Adjust INTENSITY Control (35) cw and FOCUS Control (37) appropriately to obtain a sharp visible trace display.   |
| <b>NOTE</b> |  |
|             | ● Warm-up time of CRT is approximately 30 seconds from a "cold" start-up; trace display will not become visible until CRT achieves warm-up.                    |
| 6.          | Adjust VERT Control (38) and HORIZ Control (36) to center scope trace over major horizontal axis of CRT.   |
| 7.          | Apply signal to be measured to SCOPE IN Connector (26) using a scope probe or coax. If a scope probe is used, make sure ground lead is attached to UUT ground. |

#### **CAUTION**

- DO NOT APPLY MORE THAN 200 VOLTS (PEAK-TO-PEAK) TO SCOPE IN Connector (26).



## STEP

## PROCEDURE

8. Adjust SWEEP Control (27) and EXT V/DIV Control (31) to obtain a stable waveform display of signal being measured. EXT V/DIV Vernier Control (30) may also be adjusted to achieve desired amplitude of waveform, however, SWEEP Vernier Control (28) must be in "CAL" position (fully cw, detent).

**NOTE**

- To facilitate measurement of one wavelength of displayed signal, adjust SWEEP Control to produce a waveform with a minimum number of cycles.
- At certain signal frequencies, adjustment of SWEEP Control (27) may produce at best, a closely packed waveform containing numerous cycles or multiple (and possible unstable) waveforms not in phase. See examples below:

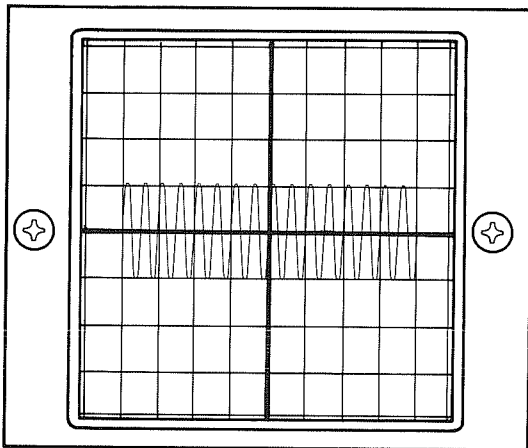

CLOSELY PACKED WAVEFORM

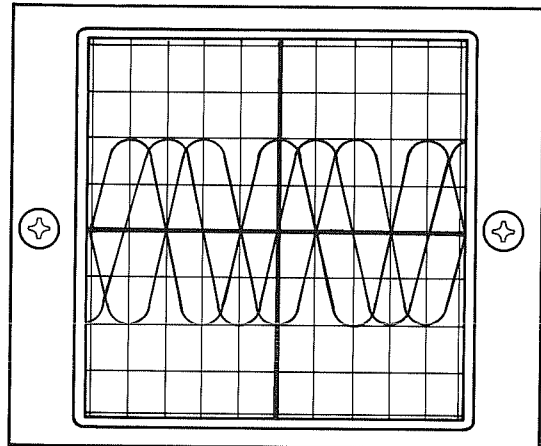

MULTIPLE WAVEFORMS NOT IN PHASE

FIGURE 4-8 EXAMPLES OF CLOSELY PACKED AND MULTIPLE WAVEFORMS

In this situation, operator should select waveform where an accurate measurement of one wavelength (in major graticule divisions) can be made most easily.

9. When a waveform suitable for measurement has been obtained on CRT, use HORIZ Control (36) and VERT Control (38) to align waveform on CRT as follows:
- Adjust VERT Control (38) to center waveform over any horizontal axis.
  - Adjust HORIZ Control so any "positive going zero crossing" of waveform is aligned with any vertical axis.

STEP

PROCEDURE

9. (cont'd)

POSITIVE GOING ZERO CROSSING OF WAVEFORM ALIGNED WITH VERTICAL AXIS

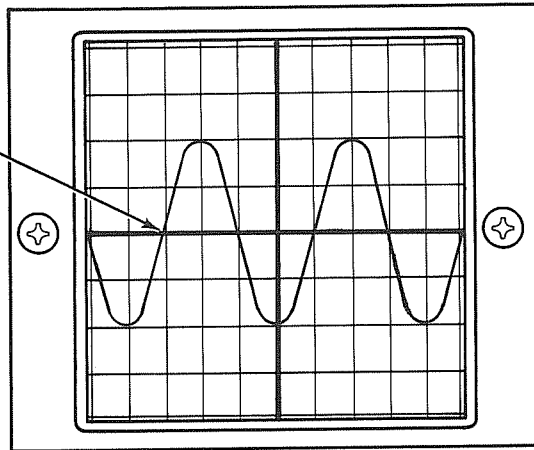
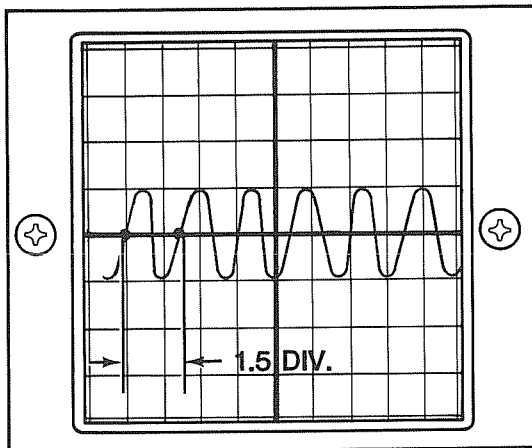

FIGURE 4-9 POSITIVE GOING ZERO POINT OF WAVEFORM ALIGNED WITH VERTICAL AXIS

10. Count number of vertical graticule divisions per one full wavelength, starting at the "positive going zero crossing" aligned in Step 9b. Record this number.

EXAMPLES:



1 WAVELENGTH = 1.5 GRAT. DIV.

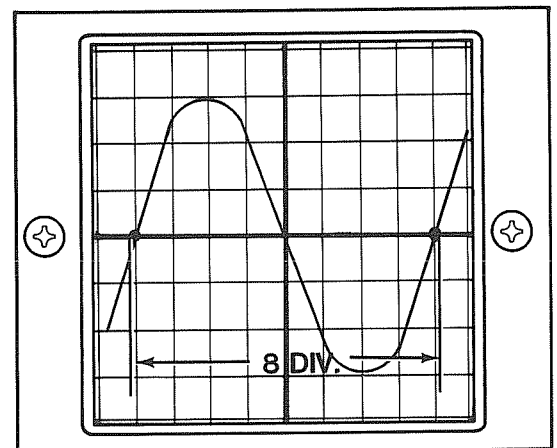

1 WAVELENGTH = 8 GRAT. DIV.

FIGURE 4-10 MEASURING WAVELENGTH IN GRATICULE DIVISIONS

11. Apply result obtained in Step 10 to following formula:

$$\frac{\text{No. of graticule divisions}}{1} \times \text{Setting of SWEEP Control} = \text{Approx. frequency of signal under test}$$

STEP PROCEDURE

11. (cont'd)

EXAMPLE: If the result obtained in Step 10 is 2.5 graticule divisions and setting of SWEEP Control (27) is 0.1 milliseconds, the formula is solved as follows:

$$\frac{1}{(2.5) \times (0.1 \text{ milliseconds})}$$

$$\frac{1}{(2.5) \times (.0001)}$$

$$\frac{1}{.00025} = 4000 \text{ Hz}$$

The result of this equation represents approximate frequency of signal under test.

-----  
 (For more accurate frequency measurement using "Lissajou" method, perform Steps 12 thru 18.)

12. Place SWEEP Control (27) to "MODULATION FREQ Hz" position. Oscilloscope will now display a solid trace area randomly positioned on CRT.
13. Adjust INT MOD Control (23), EXT V/DIV Control (31) EXT V/DIV Vernier Control (30), HORIZONTAL Control (36) and VERT Control (38) to create a comfortably sized solid square trace area on scope display.

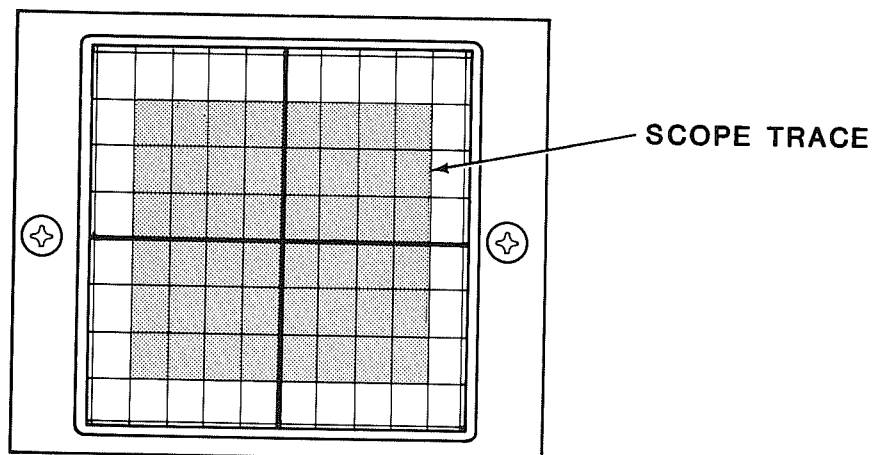

FIGURE 4-11 SOLID SQUARE TRACE AREA DISPLAYED ON CRT

## STEP

## PROCEDURE

14. Set MODULATION FREQ Hz Thumbwheels (25) to signal frequency obtained in Step 11, if that frequency is no greater than 9999.9 Hz.
- a. If frequency exceeds 9999.9 Hz, perform following mathematical operation:
- | If frequency obtained<br>in Step 11 is: | Divide that<br>frequency by: |
|---|------------------------------|
| 10 kHz to 19.999 kHz                    | 2                            |
| 20 kHz to 29.999 kHz                    | 3                            |
| 30 kHz to 39.999 kHz                    | 4                            |
| 40 kHz to 49.999 kHz                    | 5                            |
- b. Set MODULATION FREQ Hz Thumbwheels (25) to resultant frequency obtained in Step 14a.
15. To determine exact frequency of signal being measured, operator must obtain a stable Lissajou figure on CRT. First determine the order of Lissajou figure being sought by referring to following table:

FREQ. OBTAINED IN STEP 11	LISSAJOU ORDER *
5 Hz to 9999.9 Hz	1 (First)
10 kHz to 19.999 kHz	2 (Second)
20 kHz to 29.999 kHz	3 (Third)
30 kHz to 39.999 kHz	4 (Fourth)
40 kHz to 49.999 kHz	5 (Fifth)

(\* See reference chart on page 4-25 for illustration of Lissajou figures.)



16. Begin incrementing or decrementing MODULATION FREQ Hz Thumbwheels (25) in 10 Hz steps, while carefully observing scope trace for any radical, yet brief oscillation which might be the Lissajou figure being sought. Generally, the exact frequency of the signal under test will be within  $\pm 20\%$  of approximate frequency obtained in Step 11.
17. Once the oscillation of scope trace has been detected, continue incrementing or decrementing MODULATION FREQ Hz Thumbwheels (25) in smaller increments until a clear Lissajou figure is visible. Continue until figure is stationary or moving as slowly as possible.

## STEP

## PROCEDURE

18. Record present setting of MODULATION FREQ Hz Thumbwheels (25). Use table below to determine exact frequency of signal under test:

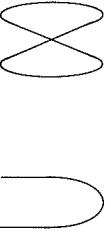
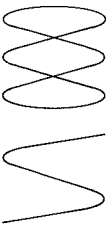
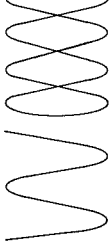
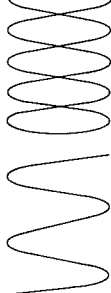
If frequency obtained in Step 11 was:	Multiply present setting of MODULATION FREQ Hz Thumbwheels (25) by corresponding number below to obtain exact frequency of signal under test:
5 Hz to 9999.9 kHz	1
10 kHz to 19.999 kHz	2
20 kHz to 29.999 kHz	3
30 kHz to 39.999 kHz	4
40 kHz to 49.999 kHz	5

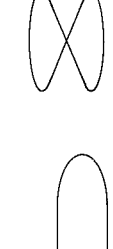
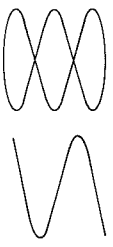
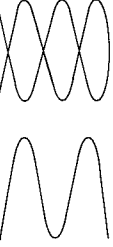
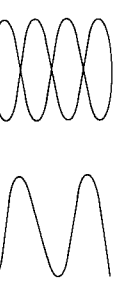
1st ORDER	2nd ORDER	3rd ORDER	4th ORDER	5th ORDER
 <p>REFERENCE FREQUENCY EQUALS FREQUENCY UNDER TEST</p>	 <p>REFERENCE FREQUENCY EQUALS HALF THE FREQUENCY UNDER TEST</p>	 <p>REFERENCE FREQUENCY EQUALS ONE THIRD OF THE FREQUENCY UNDER TEST</p>	 <p>REFERENCE FREQUENCY EQUALS ONE FOURTH OF FREQUENCY UNDER TEST</p>	 <p>REFERENCE FREQUENCY EQUALS ONE FIFTH OF FREQUENCY UNDER TEST</p>
 <p>REFERENCE FREQUENCY EQUALS FREQUENCY UNDER TEST</p>	 <p>REFERENCE FREQUENCY EQUALS TWICE THE FREQUENCY UNDER TEST</p>	 <p>REFERENCE FREQUENCY EQUALS THREE TIMES THE FREQUENCY UNDER TEST</p>	 <p>REFERENCE FREQUENCY EQUALS FOUR TIMES THE FREQUENCY UNDER TEST</p>	 <p>REFERENCE FREQUENCY EQUALS FIVE TIMES THE FREQUENCY UNDER TEST</p>

REFERENCE FREQUENCY = SETTING OF "MODULATION THUMBWHEELS"(25)  
 FREQUENCY UNDER TEST = SIGNAL APPLIED TO "SCOPE-IN CONNECTOR"(26)

FIGURE 4-12 LISSAJOU FIGURE REFERENCE CHART



## 4-2-8

TEST PROCEDURE: **MEASURING PULSE DURATION AND DUTY CYCLE**

TEST OBJECTIVE: N/A

SPECIAL ACCESSORY  
EQUIPMENT REQ'D: N/A

TEST SET-UP  
DIAGRAM: N/A

- | STEP | PROCEDURE  |
|------|--|
| 1.   | Set FM/AM-1000S controls for oscilloscope operation as shown in Figure 4-1, page 4-5.                          |
| 2.   | Apply power to FM/AM-1000S.  |
| 3.   | Adjust INTENSITY Control (35) cw and FOCUS Control (37) appropriately to obtain a sharp visible trace display. |

### **NOTE**

- Warm-up time of CRT is approximately 30 seconds from a "cold" start-up; trace display will not become visible until CRT achieves warm-up.
- |    |  |
|----|--|
| 4. | Adjust VERT Control (38) and HORIZ Control (36), to obtain a centered trace aligned along major horizontal axis.   |
| 5. | Apply power to UUT.  |
| 6. | Apply signal to be measured to a SCOPE IN Connector (26) using a scope probe or coax. If scope probe is used, make sure ground lead is attached to UUT ground. |

### **CAUTION**

- DO NOT APPLY MORE THAN 200 VOLTS (PEAK-TO-PEAK) TO SCOPE IN CONNECTOR (26).
- |    |   |
|----|---|
| 7. | Adjust EXT V/DIV Control (31) and EXT V/DIV Vernier Control (30) to obtain a comfortable square wave display. |
| 8. | Adjust SWEEP Control (27) to obtain a minimum number of pulses.   |

### **NOTE**

- A minimum of two complete pulses must be displayed.



STEP

PROCEDURE

9. Adjust HORIZ Control (36) so a "rising edge" of a given pulse is aligned with leftmost vertical axis. Adjust VERT Control (38) so "off-time" of pulse waveform is aligned along major horizontal axis. Display of pulse waveform should now appear as shown:

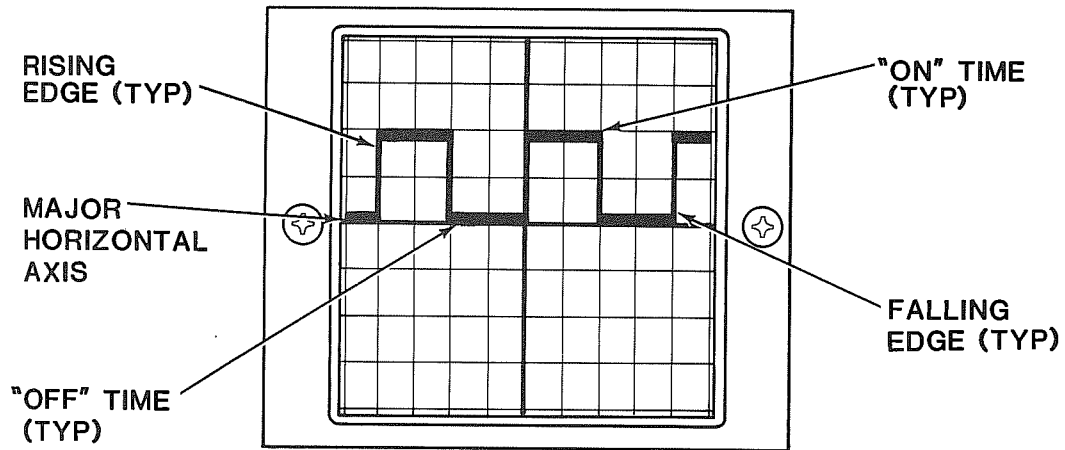

FIGURE 4-13 TYPICAL DISPLAY OF PULSE WAVEFORM

10. Count number of graticule divisions between rising edge of a given pulse and next falling edge; this distance represents time pulse is "ON."

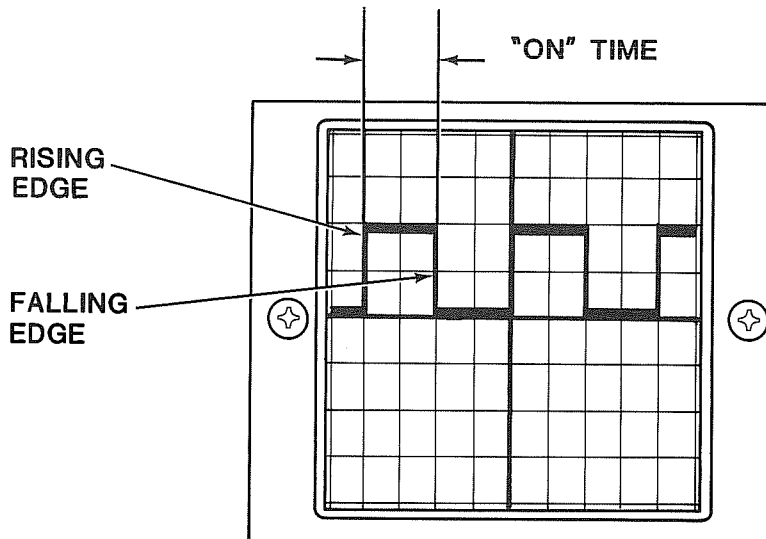

FIGURE 4-14 MEASURING "ON" TIME OF PULSE WAVEFORM

11. Multiply number of graticule divisions representing pulse "ON" time by setting of SWEEP Control (27). Record result.

STEP

PROCEDURE

12. Count number of graticule divisions between rising edge of a given pulse and next rising edge; this distance represents pulse recurrence time (PRT).

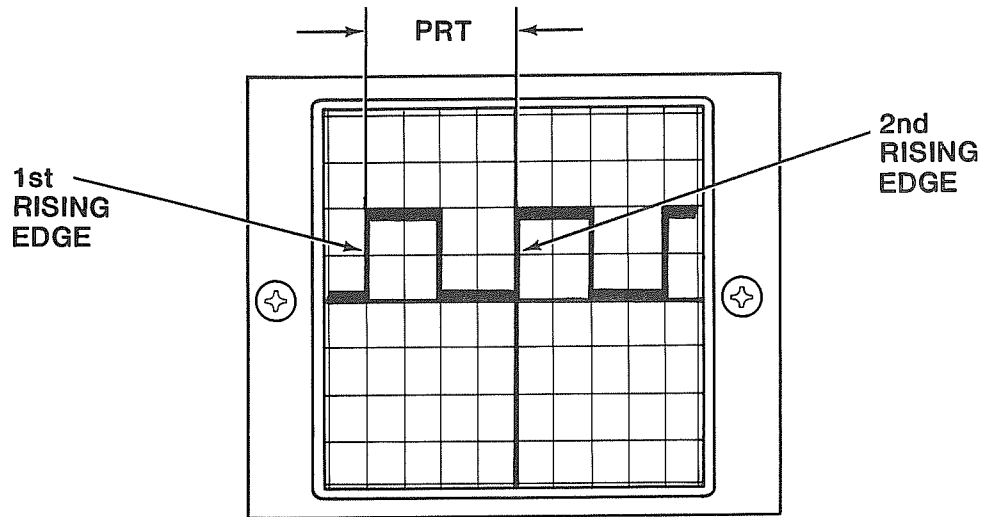

FIGURE 4-15 MEASURING PRT OF PULSE WAVEFORM

13. Multiply number of graticule divisions representing "PRT" by setting of SWEEP Control (27). Record result.
14. To determine duty cycle, apply results from Steps 11 and 13 to following formula:

$$\frac{\text{Result of Step 11}}{\text{Result of Step 13}} \times 100 = \% \text{ DUTY CYCLE}$$



---

## **4-3 TEST PROCEDURES USING FM/AM-1000S SPECTRUM ANALYZER**

#### 4-3-1 GENERAL

The FM/AM-1000S spectrum analyzer can be used for:

1. Measuring received signal strength and frequency.
2. Displaying the frequency relationship between two or more signals.
3. Displaying the frequency distribution of a signal.
4. Detecting presence of modulation and unwanted or spurious signals.

The dynamic range of the analyzer is 70 dB, covering a range from -30 dBm to -100 dBm.

The test procedures contained in this section are:

- 4-3-3 MEASURING SIGNAL STRENGTH
- 4-3-4 DETECTING SPURIOUS SIGNALS

## 4-3-2 INITIAL FM/AM-1000S CONTROL SETTINGS FOR SPECTRUM ANALYZER OPERATION

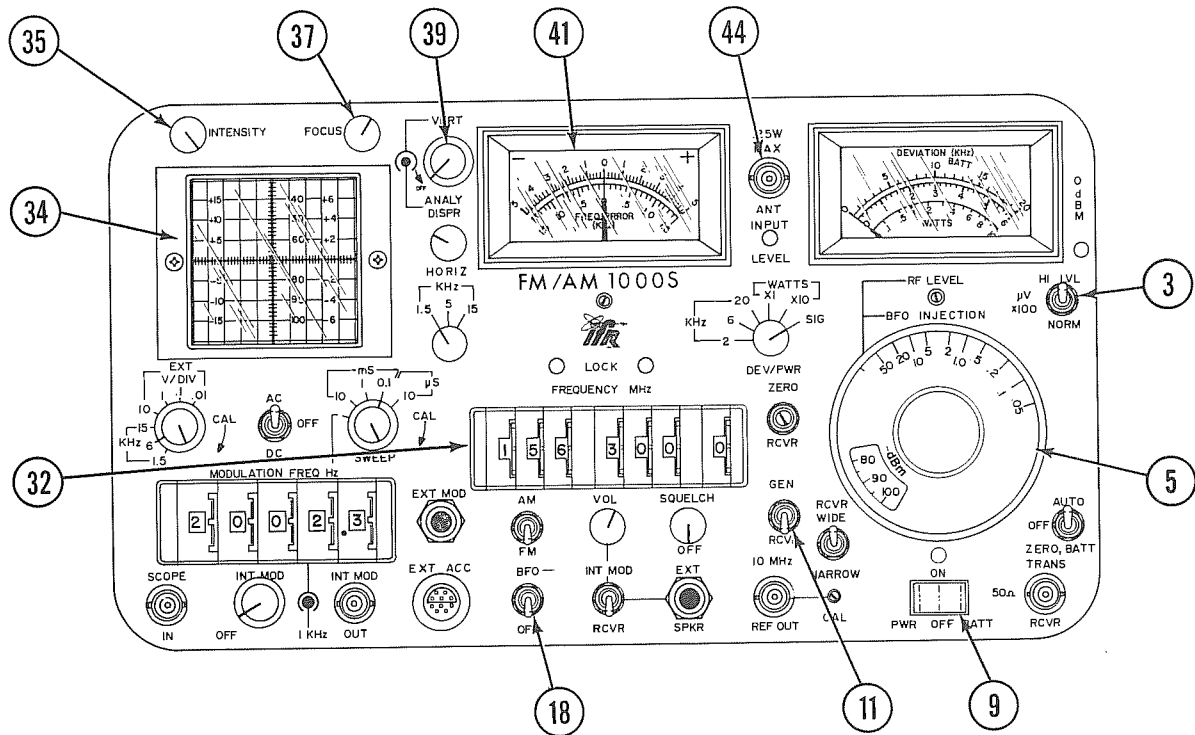

FIGURE 4-16 FM/AM-1000S CONTROLS APPLICABLE TO SPECTRUM ANALYZER OPERATION

(Refer to "SECTION 3 - DESCRIPTION OF CONTROLS, CONNECTORS & INDICATORS" for functional description of any controls used in this section.)

### NOTE

- Before performing any procedures contained in this section pertaining to spectrum analyzer operation, make sure all applicable test set controls are positioned as outlined below.
- Some of the control settings outlined below may be changed during the course of a given procedure; all controls, however, should be reset to initial positions described below when starting a new procedure.

CONTROL	INITIAL SETTING
3 HI LVL/ $\mu$ Vx100/NORM Switch	"NORM" position
5 RF LEVEL/BFO INJECTION Dial	Fully ccw
9 PWR/OFF/BATT Switch	"OFF" position
11 GEN/RCVR Switch	"RECEIVER" position
18 BFO/OFF Switch	"OFF" position
35 INTENSITY Control	Midrange position
37 FOCUS Control	Midrange position
39 ANALY DISPR Control	Fully cw

#### **4-3-2 INITIAL FM/AM-1000S CONTROL SETTINGS FOR SPECTRUM ANALYZER OPERATION (CONT'D)**

Other FM/AM-1000S features related to spectrum analyzer operation, but not requiring an initial setting:

- 32 FREQUENCY MHZ Thumbwheels
- 34 CRT Display
- 41 FREQ ERROR Meter
- 44 ANT INPUT Connector

The FM/AM-1000S is now ready for spectrum analyzer operation.

### 4-3-3

TEST PROCEDURE: **MEASURING SIGNAL STRENGTH**

TEST OBJECTIVE: N/A

SPECIAL ACCESSORY  
EQUIPMENT REQ'D: N/A

TEST SET-UP  
DIAGRAM: N/A

- | STEP | PROCEDURE  |
|------|--|
| 1.   | Set FM/AM-1000S controls for spectrum analyzer operation as shown in Figure 4-16, page 4-33. |
| 2.   | Connect external antenna to ANT INPUT Connector (44).  |

#### **CAUTION**

- MAXIMUM CONTINUOUS INPUT TO THIS CONNECTOR MUST NOT EXCEED .25 W.
  - MAXIMUM INPUT IS -30 dBm FOR PROPER SPECTRUM ANALYZER OPERATION (signals above -30 dBm may cause spurious signals to be generated and displayed by FM/AM-1000S.)
  - IF AN EXTERNAL ANTENNA ATTACHED TO AN UNTERMINATED COAX CABLE IS USED, REMOVE ANY POSSIBLE STATIC CHARGE FROM ANTENNA COAX BEFORE CONNECTION TO FM/AM-1000S.
3. Apply power to FM/AM-1000S.
4. Adjust INTENSITY Control (35) cw and FOCUS Control (37) appropriately to obtain a sharp visible trace display.

#### **NOTE**

- Warm-up time of CRT is approximately 30 seconds from a "cold" start-up; trace display will not become visible until CRT achieves warm-up.



STEP

PROCEDURE

5. Adjust FREQUENCY MHz Thumbwheels (32) so desired signal is aligned along major vertical axis on CRT. Signal to be measured is now on center frequency.

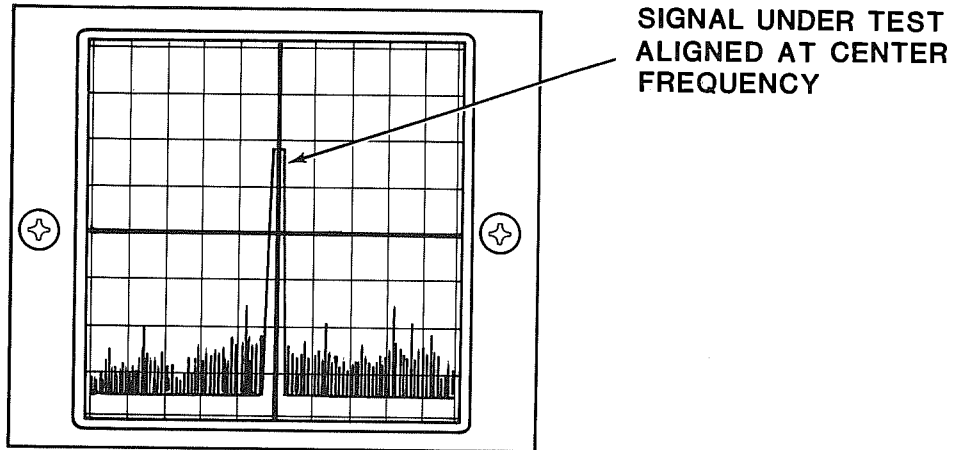

FIGURE 4-17 SIGNAL UNDER TEST DISPLAYED AT CENTER FREQUENCY

6. Rotate ANALY DISPR Control (39) fully ccw, short of detent position.
7. Again adjust FREQUENCY MHz Thumbwheels (32) so desired signal is aligned along major vertical axis on CRT.
8. Measure peak of displayed signal along vertical dB scale. Record measured result.

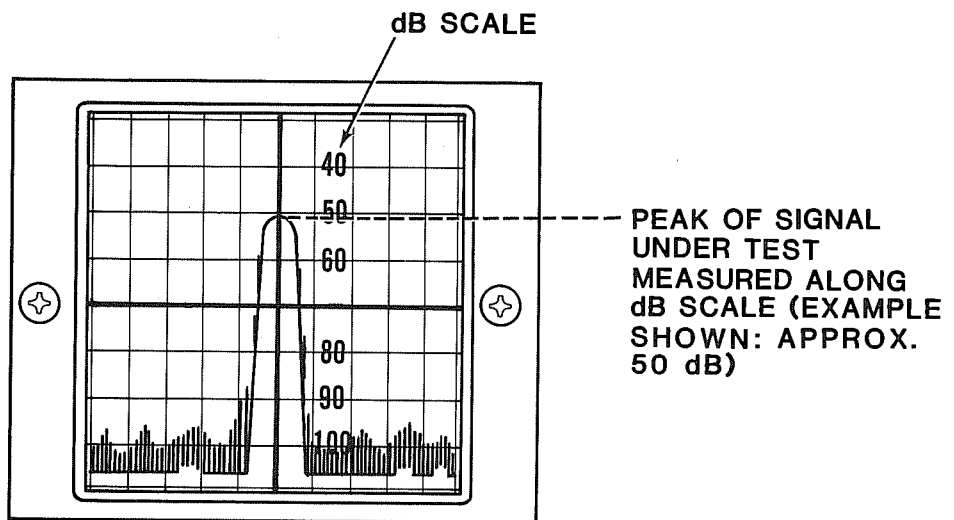

FIGURE 4-18 SIGNAL UNDER TEST MEASURED ALONG dB SCALE OF CRT

## STEP

## PROCEDURE

9. Offset displayed signal to either side of major vertical axis two (2) major graticule divisions by incrementing or decrementing FREQUENCY MHz Thumbwheels (32).

SIGNAL UNDER TEST  
OFFSET FROM MAJOR  
VERTICAL AXIS BY 2  
GRATICULE DIVISIONS

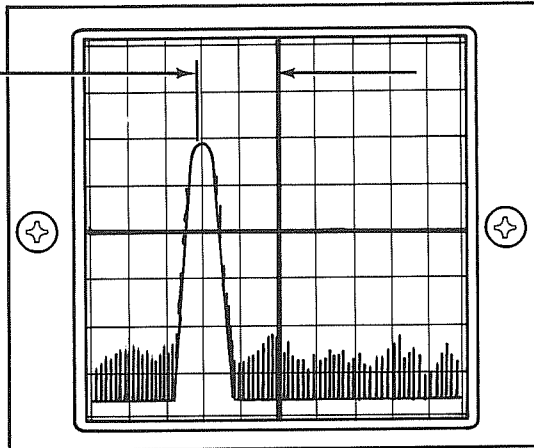

FIGURE 4-19 SIGNAL UNDER TEST OFFSET FROM MAJOR VERTICAL AXIS

10. Place BFO/OFF Switch (18) to "BFO" (ON) position.
11. Rotate RF LEVEL/BFO INJECTION Dial (5) cw so injected BFO signal is the same amplitude as signal under test.

**NOTE**

- If injected BFO signal cannot be raised to amplitude of signal under test, set HI LVL/ $\mu$ V X 100/NORM Switch (3) to " $\mu$ V x 100" position. Again rotate RF LEVEL/BFO INJECTION Dial (5) cw until injected BFO signal matches amplitude of signal under test.

STEP

PROCEDURE

11. (cont'd)

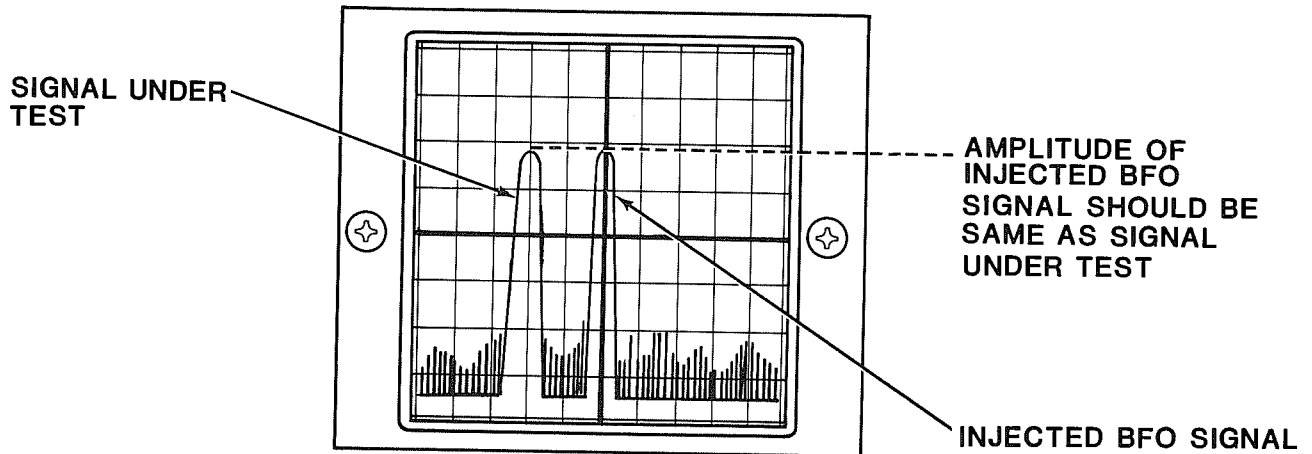

FIGURE 4-20 ADJUSTING INJECTED BFO SIGNAL TO SAME AMPLITUDE OF SIGNAL UNDER TEST

12. Read signal strength of signal under test on " $\mu\text{V}$ " or "dBm" scales of RF LEVEL/BFO INJECTION Dial (5) as follows:
- If HI LVL/ $\mu\text{V}$  X 100/NORM Switch (3) positioned to "NORM", setting of RF LEVEL/BFO INJECTION Dial (5) represents measured signal strength.
  - If HI LVL/ $\mu\text{V}$  X 100/NORM Switch (3) is positioned to " $\mu\text{V}$  x 100" position, add +40 dBm to reading of RF LEVEL/BFO INJECTION Dial (5) on dBm scale to obtain true signal strength in dBm. For equivalent signal strength in " $\mu\text{V}$ ", multiply " $\mu\text{V}$ " setting of RF LEVEL/BFO INJECTION Dial (5) by 100.

EXAMPLE:

- (1) If RF LEVEL/BFO INJECTION Dial (5) reading is -100 dBm, obtain true signal strength as follows:

$$\begin{aligned} -100 \text{ dBm} + (+40 \text{ dBm}) &= \\ -100 \text{ dBm} + 40 \text{ dBm} &= -60 \text{ dBm} \end{aligned}$$

#### 4-3-4

TEST PROCEDURE: **DETECTING SPURIOUS SIGNALS**

TEST OBJECTIVE: N/A

SPECIAL ACCESSORY  
EQUIPMENT REQ'D: N/A

TEST SET-UP  
DIAGRAM: N/A

- | STEP | PROCEDURE  |
|------|--|
| 1.   | Set FM/AM-1000S controls for spectrum analyzer operation as shown in Figure 4-16, page 4-33. |
| 2.   | Connect external antenna to ANT INPUT Connector (44) for "off-the-air" monitoring.           |

#### **CAUTION**

- MAXIMUM CONTINUOUS INPUT TO ANT INPUT Connector MUST NOT EXCEED .25 W.
- MAXIMUM INPUT TO ANT INPUT Connector IS -30 dBm FOR PROPER SPECTRUM ANALYZER OPERATION (signals above -30 dBm may cause spurious signals to be generated and displayed by FM/AM-1000S.)
- IF AN EXTERNAL ANTENNA ATTACHED TO AN UNTERMINATED COAX CABLE IS USED, REMOVE ANY POSSIBLE STATIC CHARGE FROM ANTENNA COAX BEFORE CONNECTION TO FM/AM-1000S.
- IF SIGNAL IS TO BE MONITORED THROUGH A UUT VIA A DIRECT CABLE CONNECTION TO TRANS/RCVR CONNECTOR (7), DO NOT APPLY MORE THAN 20 WATTS OF CONTINUOUS INPUT TO TRANS/RCVR CONNECTOR (7). Maximum "ON" time for measurement of transmitter output using TRANS/RCVR Connector is:

10 seconds at 100 W, 15% Duty Cycle  
20 seconds at 50 W, 30% Duty Cycle  
2 minutes at 30 W, 50% Duty Cycle

- |    |                                     |
|----|-------------------------------------|
| 3. | Apply power to FM/AM-1000S.         |
| 4. | Apply power to UUT (if applicable). |

## STEP

## PROCEDURE

5. Adjust INTENSITY Control (35) cw and FOCUS Control (37) appropriately for a sharp visible trace on CRT.

**NOTE**

- Warm-up time of CRT is approximately 30 seconds from a "cold" start-up; trace display will not become visible until CRT achieves warm-up.

6. Set FREQUENCY MHz Thumbwheels (32) to desired center frequency.
7. Momentarily shut off and re-apply power to UUT (or in case of a transmitter spectral purity check, key transmitter up and down), while carefully observing carrier signal and surrounding span for any spurious signals.

**NOTE**

- While interrupting power to UUT (or keying transmitter up and down) certain momentary spikes which protrude above the noise level may appear. Disregard these momentary spikes; look for signals which remain constant in amplitude during this time.

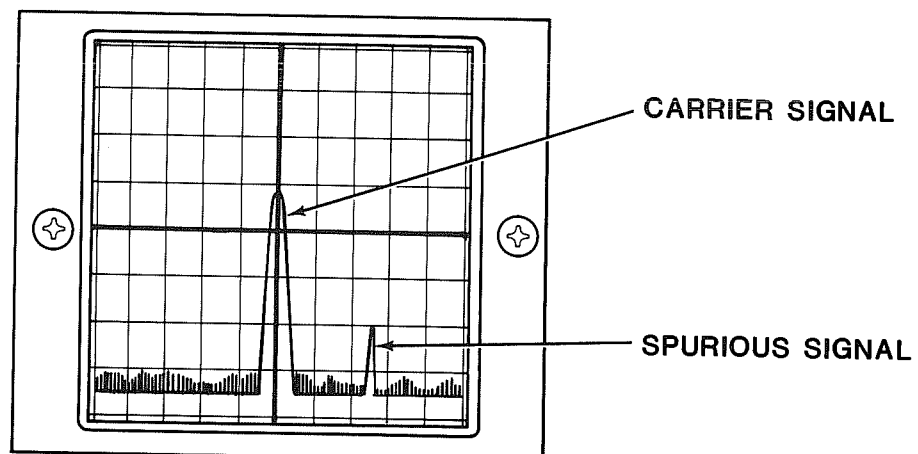

FIGURE 4-21 TYPICAL DISPLAY OF CARRIER SIGNAL AND ADJACENT SPURIOUS SIGNAL

8. To determine origin of spurious signal, increment or decrement 1 MHz and 100 kHz segments of FREQUENCY MHz Thumbwheels (32) several times above or below center frequency.
- a. If the spurious signal moves closer to or further away from carrier signal, spurious signal is being produced by FM/AM-1000S and thus can be disregarded.

## STEP

## PROCEDURE

8. (cont'd)

b. If spurious signal moves in same direction and same distance as carrier signal, spurious signal is being produced by UUT.

9. To determine frequency of spurious signal.

a. Increment or decrement the FREQUENCY MHz Thumbwheels (32), while rotating ANALY DISPR Control (39) ccw until the spurious signal is aligned with major vertical axis. Present setting of FREQUENCY MHz Thumbwheels (32) represents frequency of spurious signal.

**NOTE**

- ANALY DISPR Control (39) should be fully ccw, short of detent when final frequency reading is taken.
- To verify actual center of FM/AM-1000S Spectrum Analyzer when in wide dispersion (ANALY DISP Control fully cw), place GEN/RCVR Switch (11) to "GEN" position and observe generated signal:
  - (1) If generated signal is aligned with major vertical axis, frequency of detected spurious signal is equal to setting of FREQUENCY MHz Thumbwheels (32).
  - (2) If generated signal is not centered over major vertical axis, note position of generated signal on CRT graticule; place GEN/RCVR Switch (11) to "RCVR" position and increment or decrement FREQUENCY MHz Thumbwheels (32) to align spurious signal to same position to which generated signal was previously aligned. Setting of FREQUENCY MHz Thumbwheels (32) now represent frequency of detected spurious signal.



## **4-4 TEST PROCEDURES USING FM/AM-1000S DUAL TONE GENERATOR**



#### **4-4-1 GENERAL**

The FM/AM-1000S contains a dual tone generator capable of generating an approximate 1 kHz fixed audio tone, as well as an audio tone that is variable between 10 Hz and 9999.9 Hz (in 0.1 Hz increments). In addition, an external tone input connector on the FM/AM-1000S front panel permits the introduction of a third audio tone from an external signal source. Using this feature, the operator can produce audio frequency signals suitable for:

1. Signaling or testing audio frequency equipment.
2. Amplitude or frequency modulating FM/AM-1000S signal generator output.
3. Frequency comparison.

The procedures contained in this section are:

- 4-4-3 GENERATING AUDIO TONES OF KNOWN AMPLITUDE
- 4-4-4 USING FM/AM-1000S SPEAKER TO ACCOUSTICALLY EXCITE A MICROPHONE

## 4-4-2 INITIAL FM/AM-1000S CONTROL SETTINGS FOR DUAL TONE GENERATOR OPERATION

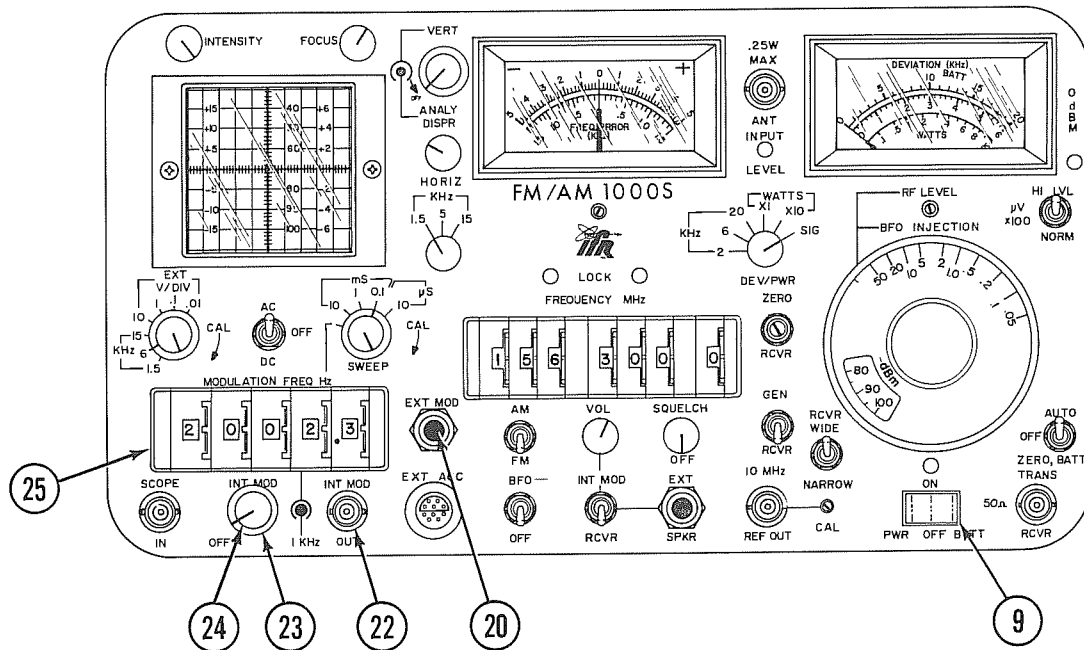

FIGURE 4-22 FM/AM-1000S CONTROLS APPLICABLE TO DUAL TONE GENERATOR OPERATION

(Refer to "SECTION 3 - DESCRIPTION OF CONTROLS, CONNECTORS & INDICATORS" for functional description of any controls used in this section.)

### NOTE

- Before performing any procedures contained in this section pertaining to dual tone generator operation, make sure all applicable test set controls are positioned as outlined below.
- Some of the control settings outlined below may be changed during the course of a given procedure; all controls, however, should be reset to initial positions described below when starting a new procedure.

CONTROL	INITIAL SETTING
9 PWR/OFF/BATT Switch	"OFF" position
23 INT MOD Control	Fully ccw, detent (OFF)
24 1 kHz INT MOD FREQ Control	Fully ccw, detent (OFF)
25 MODULATION FREQ MHz Thumbwheels	0000.0 Hz

#### **4-4-2 INITIAL FM/AM-1000S CONTROL SETTINGS FOR DUAL TONE GENERATOR OPERATION (CONT'D)**

Other FM/AM-1000S features related to dual tone generator operation, but not requiring an initial setting:

- 20 EXT MOD Connector
- 22 INT MOD OUT Connector

The FM/AM-1000S is now ready for dual tone generator operation.

## 4-4-3

TEST PROCEDURE: **GENERATING AUDIO TONES OF KNOWN AMPLITUDE**

TEST OBJECTIVE: Setting up FM/AM-1000S dual tone generator for audio signal injection into UUT.

## SPECIAL ACCESSORY

## EQUIPMENT REQ'D:

1 BNC "tee" connector.

1 short coax cable with male BNC connector on each end.

1 coax cable with male BNC connector on one end and UUT connector on opposite end.

TEST SET-UP  
DIAGRAM:

FIGURE 4-23 TEST SET-UP DIAGRAM FOR INJECTING TONE(S) OF KNOWN AMPLITUDE INTO A UUT

- | STEP | PROCEDURE   |
|------|---|
| 1.   | Set FM/AM-1000S controls for oscilloscope operation as shown in Figure 4-1, page 4-5.   |
| 2.   | Set FM/AM-1000S controls for dual tone generator operation as shown in Figure 4-22, page 4-45.  |
| 3.   | Connect BNC "tee" connector to SCOPE IN Connector (26).   |
| 4.   | Connect one end of short coax cable to INT MOD OUT Connector (22) and opposite end to BNC "tee" connector previously attached to SCOPE IN Connector (26). |
| 5.   | Apply power to UUT.   |
| 6.   | Apply power to FM/AM-1000S.   |
| 7.   | Adjust INTENSITY Control (35) cw and FOCUS Control (37) appropriately for a sharp visible trace display.  |

**NOTE**

- Warm-up time of CRT is approximately 30 seconds from a "cold" start-up; trace display will not become visible until CRT achieves warm-up.

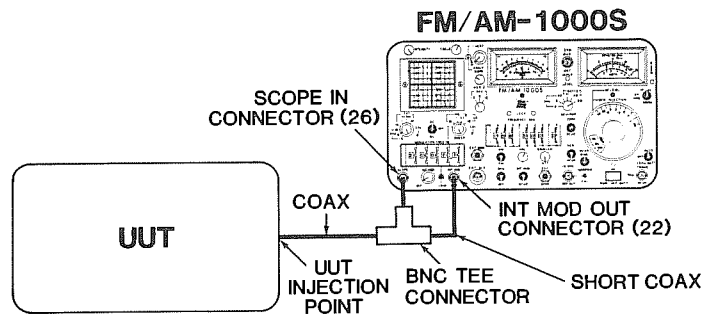
## STEP

## PROCEDURE

8. Adjust VERTICAL Control (38) and HORIZONTAL Control (36) so trace is centered and aligned along major horizontal axis.
9. Set MODULATION FREQUENCY Hz Thumbwheels (25) to desired audio frequency.
10. Connect BNC connector of remaining coax cable to "tee" connector attached to SCOPE IN Connector (26). Connect opposite end of coax cable to injection point on UUT.
11. For calibration, injected audio tone must be expressed in volts peak. Signals expressed in volts RMS or volts peak-to-peak must therefore be converted to volts peak, using following formulas.

$$\text{VOLTS PEAK} = (1.414) \times (\text{VOLTS RMS})$$

$$\text{VOLTS PEAK} = \frac{\text{Volts peak-to-peak}}{2}$$

**NOTE**

- If desired audio level is below 4 volts peak, place EXT V/DIV Control to 1 V/DIV setting.

12. Rotate INT MOD Control (23) to adjust waveform display to desired amplitude in volts peak. Desired audio tone is now being injected into UUT.

EXAMPLE:

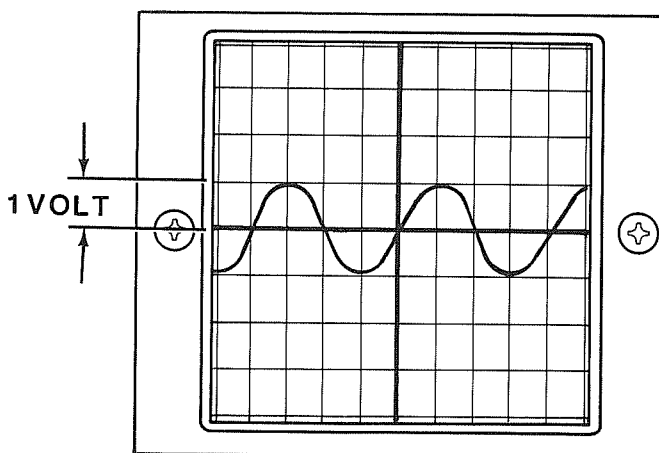

**FIGURE 4-24 AMPLITUDE OF DISPLAYED WAVEFORM ADJUSTED 1 VOLT PEAK**

13. To monitor the injected tones, place INT MOD/RCVR Switch (16) to "INT MOD" position and adjust VOL Control (17) to a comfortable listening level.

4-4-4

TEST PROCEDURE: **USING FM/AM-1000S SPEAKER TO ACCOUSTICALLY EXCITE A MICROPHONE**

TEST OBJECTIVE: Exciting an external microphone with a sine wave of a known frequency.

SPECIAL ACCESSORY  
EQUIPMENT REQ'D: N/A

TEST SET-UP  
DIAGRAM: N/A

- | STEP | PROCEDURE  |
|------|--|
| 1.   | Set FM/AM-1000S controls for dual tone generator operation as shown in Figure 4-22, page 4-45.   |
| 2.   | Set MODULATION FREQ Hz Thumbwheels (25) for desired audio modulation tone.   |
| 3.   | Place INT MOD/RCVR Switch (16) to "INT MOD" position.  |
| 4.   | Rotate INT MOD Control (23) to a midrange position.  |
| 5.   | Apply power to FM/AM-1000S.  |
| 6.   | Adjust VOL Control (17) to a comfortable listening level.  |
| 7.   | Apply power to UUT.  |
| 8.   | Key UUT microphone while holding microphone next to FM/AM-1000S internal speaker (located on right side of FM/AM-1000S). Use FM/AM-1000S monitoring features to analyze UUT modulation capabilities. |



---

**4-5 TEST PROCEDURES USING FM/AM-1000S RF GENERATOR**



## 4-5-1 GENERAL

The FM/AM-1000S signal generator is capable of generating calibrated amplitude signals from 100 Hz to 999.999 MHz (in 100 Hz increments).

### NOTE

- When HI LVL/ $\mu$ V X 100/NORM Switch (3) is positioned to "HI LVL", RF output range is 50 kHz to 999.999 MHz.

The generator function can be used to stimulate external devices by generating unmodulated RF signals, AM modulated RF signals and FM modulated RF signals. The generator output may also be swept over a short frequency span for bandwidth testing of external devices.

The procedures contained in this section are:

- 4-5-3 GENERATING RF SIGNALS
- 4-5-4 GENERATING AM MODULATED RF SIGNALS
- 4-5-5 GENERATING FM MODULATED RF SIGNALS

## 4-5-2 INITIAL FM/AM-1000S CONTROL SETTINGS FOR RF GENERATOR OPERATION

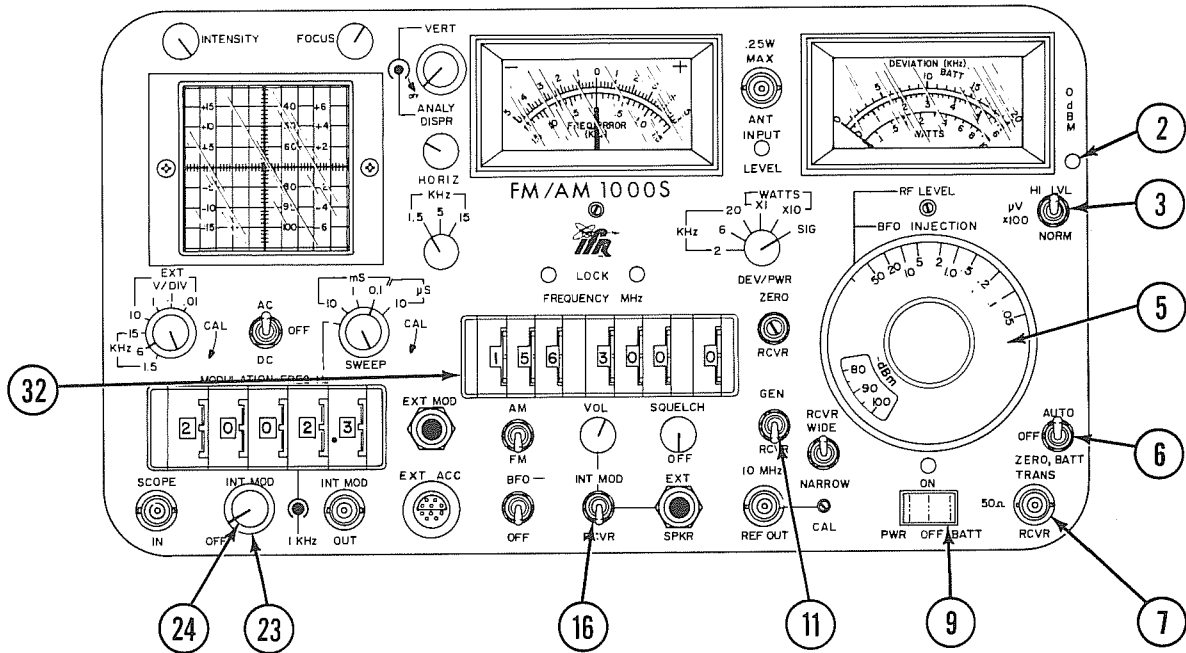

FIGURE 4-25 FM/AM-1000S CONTROLS APPLICABLE TO RF GENERATOR OPERATION

(Refer to "SECTION 3 - DESCRIPTION OF CONTROLS, CONNECTORS & INDICATORS" for functional description of any controls used in this section.)

### NOTE

- Before performing any procedures contained in this section pertaining to RF generator operation, make sure all applicable test set controls are positioned as outlined below.
- Some of the control settings outlined below may be changed during the course of a given procedure; all controls, however, should be reset to initial positions described below when starting a new procedure.

CONTROL	INITIAL SETTING
3 HI LVL/ $\mu$ V X 100/NORM Switch	"NORM" position
5 RF LEVEL/BFO INJECTION Dial	Fully ccw
6 AUTO/OFF/ZERO, BATT Switch	"AUTO" position
9 PWR/OFF/BATT Switch	"OFF" position
10 RCVR WIDE/MID/NARROW Switch	"NARROW" position
11 GEN/RCVR Switch	"GEN" position
16 INT MOD/RCVR Switch	"RCVR" position
23 INT MOD Control	Fully ccw, detent (OFF)
24 1 kHz INT MOD Control	Fully ccw, detent (OFF)

#### **4-5-2 INITIAL FM/AM-1000S CONTROL SETTINGS FOR RF GENERATOR OPERATION**

Other FM/AM-1000S features related to RF generator operation, but not requiring an initial setting:

- 2 0 dBm Lamp
- 7 TRANS/RCVR Connector
- 32 FREQUENCY MHz Thumbwheels

The FM/AM-1000S is now ready for RF generator operation.

### 4-5-3

#### TEST PROCEDURE: **GENERATING RF SIGNALS**

TEST OBJECTIVE: N/A

SPECIAL ACCESSORY  
EQUIPMENT REQ'D: N/A

TEST SET-UP  
DIAGRAM: N/A

- | STEP | PROCEDURE  |
|------|--|
| 1.   | Set FM/AM-1000S controls for RF generator operation as shown in Figure 4-25, page 4-53.                      |
| 2.   | Apply power to FM/AM-1000S.  |
| 3.   | Set FREQUENCY MHz Thumbwheels (32) to desired RF frequency output.   |
| 4.   | For an RF output less than 50 $\mu$ V, rotate RF LEVEL/BFO INJECTION Dial (5) to desired " $\mu$ V" setting. |

#### **NOTE**

- RF output in dBm can be determined by reading setting of RF LEVEL/BFO INJECTION Dial (5) on dBm scale.

The FM/AM-1000S is now generating RF signals at desired frequency and output level.

- |    |   |
|----|---|
| 5. | For an RF output level greater than 50 $\mu$ V (but less than 5000 $\mu$ V):  |
| a. | Place HI LEVEL/ $\mu$ V X 100/NORM Switch (3) to " $\mu$ V x 100" position.   |
| b. | Rotate RF LEVEL/BFO INJECTION Dial (5) to desired " $\mu$ V" setting. The FM/AM-1000S is now generating RF signals at desired frequency and output level. |

#### **NOTE**

- RF output level in " $\mu$ V" is now 100 times the setting of RF LEVEL/BFO INJECTION Dial (5) on " $\mu$ V" scale.

## STEP

## PROCEDURE

5. (cont'd)

**NOTE**

- Equivalent RF output level in dBm can be determined by mathematically adding +40 dBm to reading of RF LEVEL/BFO INJECTION Dial (5) on dBm scale.

EXAMPLE: RF output level as indicated on dial: -100 dBm

$$\begin{aligned} -100 \text{ dBm} + (+40 \text{ dBm}) &= \\ -100 \text{ dBm} + 40 \text{ dBm} &= -60 \text{ dBm output} \end{aligned}$$

6. For an RF output level greater than -35 dBm:
- Rotate RF LEVEL/BFO INJECTION Dial (5) fully ccw.
  - Place HI LVL/ $\mu$ V X 100/NORM Switch (3) to "HI LVL" position.
  - Slowly rotate RF LEVEL/BFO INJECTION Dial (5) cw until 0 dBm Lamp (2) illuminates.
  - Record setting of RF LEVEL/BFO INJECTION Dial (5) on dBm scale.
  - Add result obtained in Step 6d to desired RF output level in dBm. Record result.
  - Rotate RF LEVEL/BFO INJECTION Dial (5) to setting obtained in Step 6e.
  - The FM/AM-1000S is now generating RF signals at desired frequency and output level.

EXAMPLE:

- Desired RF output level: -25 dBm
- RF LEVEL/BFO INJECTION Dial (5) setting when 0 dBm Lamp (2) illuminates: -75 dBm
- Add (1) to (2):  $(-25) + (-75) = -100$  dBm
- Rotate RF LEVEL/BFO INJECTION Dial (5) to -100 dBm; RF output level of FM/AM-1000S is now -25 dBm.

TEST PROCEDURE: **GENERATING AM MODULATED RF SIGNALS**

TEST OBJECTIVE: N/A

SPECIAL ACCESSORY  
EQUIPMENT REQ'D: N/ATEST SET-UP  
DIAGRAM: N/A

- | STEP | PROCEDURE  |
|------|--|
| 1.   | Perform procedure 4-5-3, titled "GENERATING RF SIGNALS", on page 4-55.   |
| 2.   | Place AM/FM Switch (19) to "AM."   |
| 3.   | Set "MODULATION FREQ Hz Thumbwheels (25) to desired tone modulation frequency.   |
| 4.   | Rotate ANALY DISPR Control (39) fully ccw to detent position.  |
| 5.   | Place EXT V/DIV Control (31) to "1.5 kHz", "6 kHz" or "15 kHz" position.   |
| 6.   | Rotate EXT V/DIV Vernier Control (30) to "CAL" position.   |
| 7.   | Adjust INTENSITY Control (35) cw and FOCUS Control (37) appropriately for a sharp visible trace display.   |
| 8.   | Adjust VERT Control (38) and HORIZ Control (36) to obtain a centered trace, with lower edge of displayed carrier aligned with major horizontal axis. |

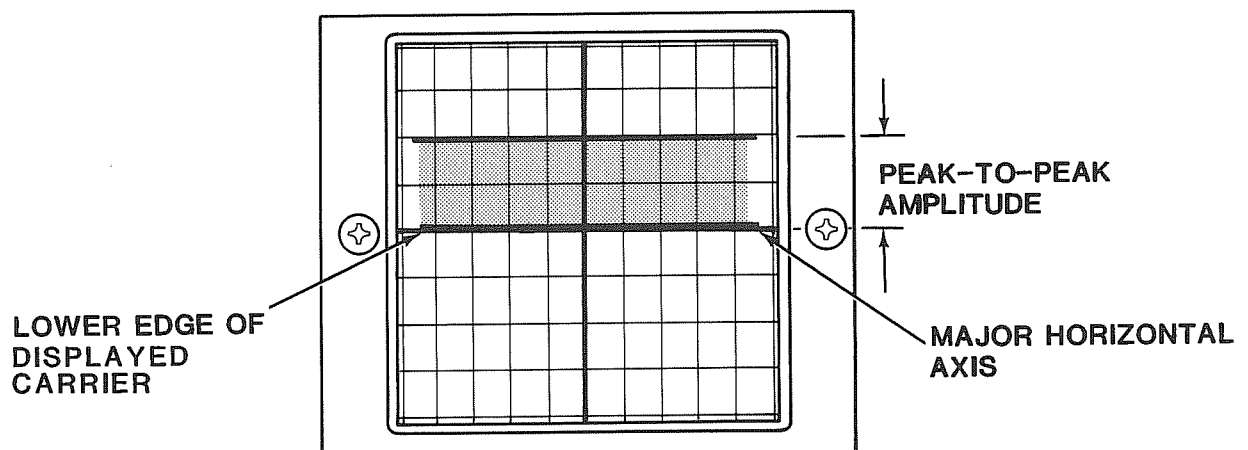

**FIGURE 4-26 DISPLAYED CARRIER ALIGNED WITH LOWER EDGE RESTING ON MAJOR HORIZONTAL AXIS**

## STEP

## PROCEDURE

9. Measure peak-to-peak amplitude (in graticule divisions) of displayed carrier. Record result.
10. Apply result obtained in Step 9 to the following equation:

$$x = \frac{(\text{desired \% modulation}) \times (\text{result of Step 9})}{100}$$

where  $x$  = number of graticule divisions (peak-to-peak) of modulated signal.

11.
  - a. Adjust VERTICAL Control (38) to align negative peak of one of the modulated signals with the major horizontal axis.
  - b. Rotate INT MOD Control (23) to adjust peak-to-peak amplitude of the same modulated signal (in graticule divisions) to the value of " $x$ " obtained in Step 10.

**NOTE**

- Steps 11a and 11b must be performed simultaneously, as both are interactive.

## EXAMPLES:

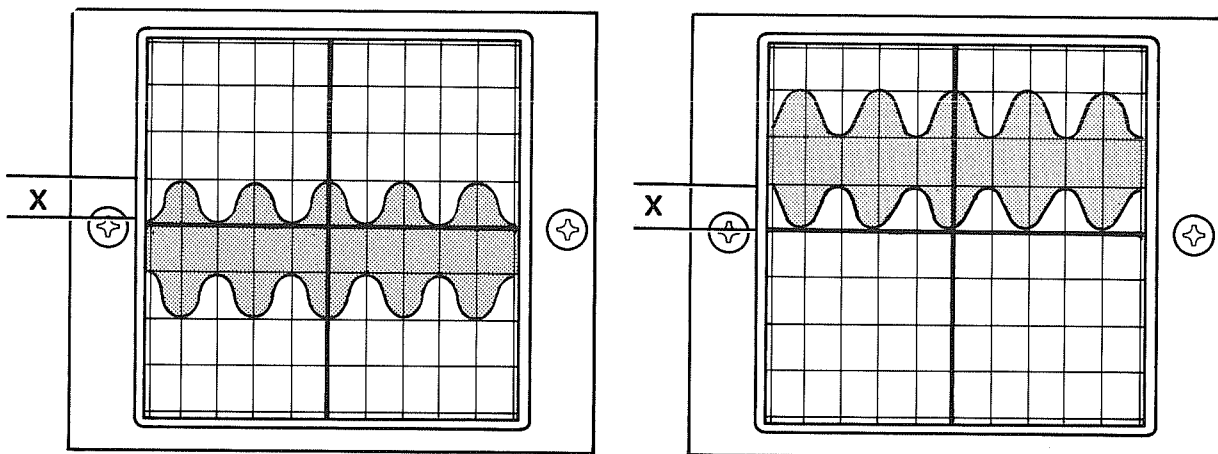

DISPLAYED WAVEFORM WITH UPPER MODULATED SIGNAL ALIGNED ALONG MAJOR HORIZONTAL AXIS

DISPLAYED WAVEFORM WITH LOWER MODULATED SIGNAL ALIGNED ALONG MAJOR HORIZONTAL AXIS

FIGURE 4-27 ALIGNMENT OF UPPER & LOWER MODULATION SIGNALS WITH MAJOR HORIZONTAL AXIS

- c. The FM/AM-1000S signal generator is now calibrated to desired percent modulation and is generating at selected frequency and output level.

## 4-5-5

TEST PROCEDURE: **GENERATING FM MODULATED RF SIGNALS**

TEST OBJECTIVE: N/A

SPECIAL ACCESSORY  
EQUIPMENT REQ'D: N/A

TEST SET-UP  
DIAGRAM: N/A

STEP	PROCEDURE
1.	Perform procedure 4-5-3, titled "GENERATING RF SIGNALS", on page 4-55.
2.	Place AM/FM Switch (19) to "FM."
3.	Set MODULATION FREQ Hz Thumbwheels (25) to desired tone modulation frequency.
4.	Place DEV/PWR Control (47) to desired deviation range (2, 6 or 20 kHz).
5.	Rotate INT MOD Control (23) cw while observing DEVIATION/WATTS Meter (1) until meter indicates desired deviation on appropriate scale.

### NOTE

- If deviation is above 5 kHz, place RCVR WIDE/MID/NARROW Switch (10) to "MID" or "WIDE" position.
- Signals at a 1 kHz rate with more than  $\pm 5$  kHz deviation must be monitored with RCVR WIDE/MID/NARROW Switch (10) in "MID" position.
- Signals modulated above 2 kHz should be monitored with RCVR WIDE/MID/NARROW Switch (10) in "WIDE" position. Note residual modulation indication due to noise on DEVIATION/WATTS Meter (1); add this value to desired value. Total represents indicated deviation value on DEVIATION/WATTS Meter (1).

The FM/AM-1000S is now generating FM modulated RF signals within desired deviation range.





---

## **4-6 TEST PROCEDURES USING FM/AM-1000S RECEIVER**

#### 4-6-1 GENERAL

The FM/AM-1000S contains a sensitive AM/FM communications receiver capable of receiving signals within a range of 300 kHz to 999.999 MHz (in 100 Hz increments). The receiver function enables the operator to measure the characteristics of most radiated signals, including CW and SSB.

The procedures contained in this section are:

- 4-6-3 RECEIVING AM OR FM SIGNALS
- 4-6-4 RECEIVING SIDEBAND SIGNALS
- 4-6-5 RECEIVING CW SIGNALS
- 4-6-6 RECEIVING TIME STANDARD SIGNAL TO CALIBRATE  
FM/AM-1000S MASTER OSCILLATOR.
- 4-6-7 CALIBRATING FM/AM-1000S MASTER OSCILLATOR  
THROUGH AN EXTERNAL FREQUENCY STANDARD.

## 4-6-2 INITIAL FM/AM -1000S CONTROL SETTINGS FOR RECEIVER OPERATION

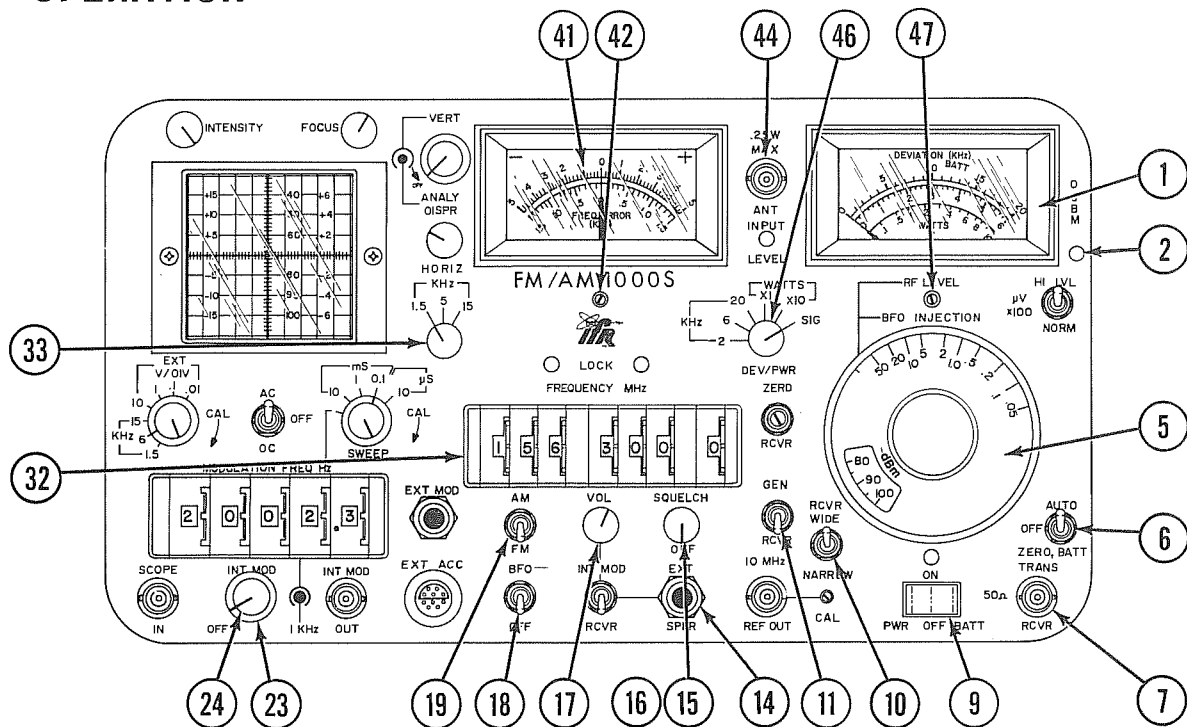

FIGURE 4-28 FM/AM-1000S CONTROLS APPLICABLE TO RECEIVER OPERATION

(Refer to "SECTION 3 - DESCRIPTION OF CONTROLS, CONNECTORS & INDICATORS" for functional description of any controls used in this section.)

### NOTE

- Before performing any procedures contained in this section pertaining to receiver operation, make sure all applicable test set controls are positioned as outlined below.
- Some of the control settings outlined below may be changed during the course of a given procedure; all controls, however, should be reset to initial positions described below when starting a new procedure.

CONTROL	INITIAL SETTING
5 RF LEVEL/BFO INJECTION Dial	Fully ccw
6 AUTO/ZERO/OFF/ZERO, Batt Switch	"AUTO" position
9 POWER/OFF/BATT Switch	"OFF" position
10 RCVR WIDE/MID/NARROW Switch	"WIDE" position
11 GEN/RCVR Switch	"RECEIVER" position
15 SQUELCH Control	Fully ccw, short of detent
16 INT MOD/RCVR Switch	"RECEIVER" position
17 VOL Control	Fully ccw
18 BFO/OFF Switch	"OFF" position

#### 4-6-2 INITIAL FM/AM-1000S CONTROL SETTINGS FOR RECEIVER OPERATION (CONT'D)

CONTROL	INITIAL SETTING
19 AM/FM Switch	"AM" or "FM" position depending on mode of signal to be received.
23 INT MOD Control	Fully ccw, detent (OFF)
24 1 kHz INT MOD Control	Fully ccw, detent (OFF)
33 1.5/5/15 kHz Control	"15 kHz" position
47 DEV/PWR Control	"SIG" position

Other FM/AM-1000S features related to receiver operation, but not requiring an initial setting:

- 1 DEVIATION/WATTS Meter
- 4 ZERO RCVR Adjustment
- 7 TRANS/RCVR Connector
- 14 EXT SPKR Connector
- 32 FREQUENCY MHz Thumbwheels
- 41 FREQ ERROR Meter
- 42 FREQ ERROR Meter Zero Adjustment
- 44 ANT INTPUT Connector
- 47 DEVIATION/WATTS Meter Zero Adjustment

The FM/AM-1000S is now ready for receiver operation.

### 4-6-3

TEST PROCEDURE: **RECEIVING AM OR FM SIGNALS**

TEST OBJECTIVE: N/A

SPECIAL ACCESSORY  
EQUIPMENT REQ'D: N/A

TEST SET-UP  
DIAGRAM: N/A

- | STEP | PROCEDURE   |
|------|---|
| 1.   | Set FM/AM-1000S controls for receiver operation as shown in Figure 4-28, page 4-63.   |
| 2.   | Place AM/FM Switch (19) to desired signal mode position.  |
| 3.   | Select desired method for signal reception:<br>a. <u>External Antenna</u><br>Connect external antenna to ANT INPUT Connector (44) for "off-the-air" monitoring. |

**CAUTION**

- MAXIMUM CONTINUOUS INPUT TO THIS CONNECTOR MUST NOT EXCEED .25 W.
  - MAXIMUM INPUT IS -30 dBm FOR PROPER SPECTRUM ANALYZER OPERATION (SIGNALS ABOVE -30 dBm MAY CAUSE SPURIOUS SIGNALS TO BE GENERATED AND DISPLAYED BY FM/AM-1000S.)
  - IF AN EXTERNAL ANTENNA ATTACHED TO AN UNTERMINATED COAX CABLE IS USED, REMOVE ANY POSSIBLE STATIC CHARGE FROM ANTENNA COAX BEFORE CONNECTING TO FM/AM-1000S.
- b. Direct Cable Connection from UUT  
Connect cable from UUT to TRANS/RCVR Connector (7).

**CAUTION**

- DO NOT APPLY MORE THAN 20 WATTS OF CONTINUOUS INPUT TO TRANS/RCVR CONNECTOR (7).
- Maximum "ON" time for measurement of transmitter output using TRANS/RCVR Connector (7) is:

10 seconds at 100 W, 15% Duty Cycle  
20 seconds at 50 W, 30% Duty Cycle  
2 minutes at 30 W, 50% Duty Cycle



## STEP

## PROCEDURE

11. If received signal is being monitored through a direct cable connection at TRANS/RCVR Connector (7), rotate DEV/PWR Control (47) to "Watts x 10" position. If DEVIATION/WATTS Meter (1) reading is under 10 watts (on red scale), rotate DEV/PWR Control (47) to "Watts x 1" position.
12. Output power of UUT can now be measured on red scale of DEVIATION/WATTS Meter (1).

**NOTE**

- For signals received "off-the-air", a qualitative representation of relative signal strength can be determined by observing DEVIATION/WATTS Meter (1) needle deflection (with DEV/PWR Control (47) in "SIG" position). As signal strength increases, the meter needle deflection will increase towards right of meter scale. For exact measurement of "off-the-air" signal strength, refer to procedure 4-3-3, titled "MEASURING SIGNAL STRENGTH" on page 4-35.





#### 4-6-4

TEST PROCEDURE: **RECEIVING SIDEBAND SIGNALS**

TEST OBJECTIVE: N/A

SPECIAL ACCESSORY  
EQUIPMENT REQ'D: N/A

TEST SET-UP  
DIAGRAM: N/A

- | STEP | PROCEDURE   |
|------|---|
| 1.   | Perform procedure 4-6-3, titled "RECEIVING AM or FM SIGNALS" on page 4-65.                              |
| 2.   | Place BFO/OFF Switch (18) to "BFO" (ON) position.   |
| 3.   | Rotate RF LEVEL/BFO INJECTION Dial (5) cw until sideband becomes understandable.                        |
| 4.   | Increment or decrement FREQUENCY MHz Thumbwheels (32) in 100 Hz steps as necessary to "clarify" signal. |

#### **NOTE**

- Excessive BFO quiets the receiver and depresses audio output, while insufficient BFO causes distortion.



## 4-6-5

TEST PROCEDURE: **RECEIVING CW SIGNALS**

TEST OBJECTIVE: N/A

SPECIAL ACCESSORY  
EQUIPMENT REQ'D: N/A

TEST SET-UP  
DIAGRAM: N/A

STEP	PROCEDURE
1.	Perform all steps of procedure 4-6-3, titled "RECEIVING AM or FM SIGNALS" on page 4-65, with exception of Step 7, which is to be disregarded.
2.	Place BFO/OFF Switch (18) to "BFO" (ON) position.
3.	Place AM/FM Switch (19) to "AM" position.
4.	Increment or decrement FREQUENCY MHz Thumbwheels (32) 1 kHz or as desired.
5.	Rotate RF LEVEL/BFO INJECTION Dial (5) and VOL Control (17) cw simultaneously until beat frequency becomes audible.



## 4-6-6

TEST PROCEDURE: **RECEIVING TIME STANDARD SIGNAL TO CALIBRATE  
FM/AM-1000S MASTER OSCILLATOR**

TEST OBJECTIVE: N/A

### SPECIAL ACCESSORY

EQUIPMENT REQ'D: 1 small flatblade screwdriver  
1 short length of wire (18 ga.)

### TEST SET-UP

DIAGRAM: N/A

- | STEP        | PROCEDURE  |
|-------------|--|
| 1.          | Perform procedure 4-6-3, titled "RECEIVING AM OR FM SIGNALS" on page 4-65.   |
| <b>NOTE</b> |  |
|             | <ul style="list-style-type: none"><li>● AM/FM Switch (19) should be in "AM" position.</li><li>● Frequency to be received is 10.000 MHz (WWV Time Standard Radio Station.)</li><li>● DEV/PWR Control (47) should be in "SIG" position.</li></ul>  |
| 2.          | Set FM/AM-1000S controls for oscilloscope operation as shown in Figure 4-1, page 4-5.  |
| 3.          | Rotate EXT V/DIV Switch (31) to "15 kHz" position.   |
| 4.          | Insert a short length of wire into center conductor of 10 MHz REF OUT Connector (13).  |
| 5.          | Adjust position of wire to obtain a suitable beat note from FM/AM-1000S speaker.   |
| 6.          | Using small screwdriver, rotate 10 MHz CAL Adjustment (12) appropriately until beat note achieves as low a frequency as possible: <ul style="list-style-type: none"><li>a. Initially, it will be helpful to observe oscillation of waveform on oscilloscope while rotating 10 MHz CAL Adjustment (12); rotate screw until oscillation diminishes to a point of being as close as possible to stationary.</li></ul> |

## STEP

## PROCEDURE

6. (cont'd)

- b. Continue adjustment of 10 MHz CAL Adjustment (12) while observing DEVIATION/WATTS Meter (1) until meter needle oscillation becomes as slow as possible. During this step, recheck oscilloscope display to make sure waveform remains stable. Master oscillator of FM/AM-1000S is now calibrated in accordance with WWV.

**NOTE**

- Careful calibration can result in a beat frequency less than 0.1 Hz.
- The needle indication described in Step 6b may not occur if the WWV transmitter is in close proximity to the FM/AM-1000S.

7. In addition to calibrating the FM/AM-1000S master oscillator for accurate frequency reference/measurement, the FM/AM-1000S FREQ ERROR Meter (41) should also be zeroed for reliable frequency measurements. Procedure is as follows:

- a. Place GEN/RCVR Switch (11) to "GEN" position.

**NOTE**

- RCVR WIDE/MID/NARROW Switch (10) must be in "NARROW" position.
- b. Make sure AUTO/OFF/ZERO, BATT Switch (6) is in "AUTO" position.
  - c. Rotate 1.5/5/15 kHz Control (33) to "1.5 kHz" position.
  - d. Adjust ZERO RCVR Adjustment (4) cw or ccw to center FREQ ERROR Meter (41) needle at zero.

#### 4-6-7

TEST PROCEDURE: **CALIBRATING FM/AM-1000S MASTER OSCILLATOR THROUGH AN EXTERNAL FREQUENCY STANDARD**

TEST OBJECTIVE: Alternate procedure for calibrating FM/AM-1000S master oscillator through an external source (e.g. frequency counter) when a 10 MHz "off-the-air" reference signal is not available.

SPECIAL ACCESSORY  
EQUIPMENT REQ'D:

- 1 Coax cable with male BNC connector on each end
- 1 Frequency Counter

TEST SET-UP  
DIAGRAM:

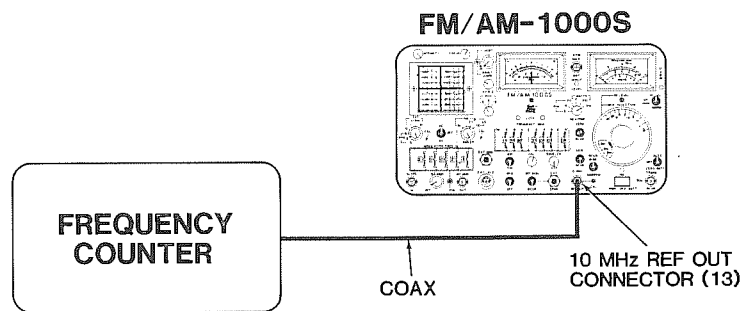

FIGURE 4-29 TEST SET-UP DIAGRAM FOR CALIBRATING FM/AM-1000S MASTER OSCILLATOR

- | STEP | PROCEDURE   |
|------|---|
| 1.   | Connect one end of coax cable to 10 MHz REFERENCE OUT Connector (13).   |
| 2.   | Connect opposite end of coax cable to input of frequency counter.   |
| 3.   | Apply power to frequency counter.   |
| 4.   | Apply power to FM/AM-1000S.   |
| 5.   | For most precise adjustment, wait approximately 5 minutes before proceeding with Step 6.  |
| 6.   | Adjust 10 MHz CAL Adjustment (12) until frequency counter reads 10 MHz, $\pm 1$ Hz. FM/AM-1000S master oscillator is now calibrated to frequency counter. |



STEP

PROCEDURE

7. In addition to calibrating the FM/AM-1000S master oscillator for accurate frequency reference/measurement, the FM/AM-1000S FREQ ERROR Meter (41) should also be zeroed for reliable frequency measurements. Procedure is as follows:
- a. Place GEN/RCVR Switch (11) to "GEN" position.

**NOTE**

- RCVR WIDE/MID/NARROW Switch (10) must be in "NARROW" position.
- b. Make sure AUTO/OFF/ZERO, BATT Switch (6) is in "AUTO" position.
  - c. Rotate 1.5/5/15 kHz Control (33) to "1.5 kHz" position.
  - d. Adjust ZERO RCVR Adjustment (4) cw or ccw to center FREQ ERROR Meter (41) needle at zero.

**4-7 TEST PROCEDURES USING FM/AM-1000S AS A SWEEP  
GENERATOR /TRACKING OSCILLOSCOPE**

## 4-7-1 GENERAL

The RF output of the FM/AM-1000S signal generator can be caused to sweep by as much as  $\pm 20$  kHz. Since the horizontal scan of the FM/AM-1000S is synchronized to the dual tone generator output, the FM/AM-1000S oscilloscope can be used to track the swept RF signal output. This permits direct viewing of filter, crystal and tuned circuit response curves on the FM/AM-1000S oscilloscope.

### IMPORTANT CONSIDERATIONS APPLICABLE TO PROCEDURES CONTAINED IN THIS SECTION:

- When using FM/AM-1000S as a Sweep Generator/Tracking Oscilloscope, frequency display on CRT is inverted; i.e. frequency is maximum on left side of CRT and minimum on right side of CRT.
- Certain circuits exhibiting severe attenuation may not provide sufficient detector output to obtain necessary scope deflection.
- A circuit under test must be highly selective to show a response curve within the 40 kHz displayed span.
- High impedance (Hi-Z) circuits should be monitored using a detector probe.
- When testing notch, highpass and lowpass circuits, best results are normally obtained at or near 0 dBm output. If smaller levels are required, use maximum output with HI LVL/ $\mu$ V X 100/NORM Switch (3) in " $\mu$ V X 100" position.
- DC blocking capacitors are required only for active circuits.
- If circuit under test (CUT) is an amplifier, make sure amplifier:
  - (1) is terminated with proper load impedance.
  - (2) power out does not exceed detector parameters.
  - (3) is not saturated.

The test procedures contained in this section are:

- 4-7-3 USING FM/AM-1000S AS A SWEEP GENERATOR/TRACKING OSCILLOSCOPE
- 4-7-4 MEASURING BANDPASS AND CENTER FREQUENCY OF A BANDPASS CIRCUIT
- 4-7-5 MEASURING BANDREJECT AND CENTER FREQUENCY OF NOTCH CIRCUITS
- 4-7-6 MEASURING CUT-OFF FREQUENCY OF LOWPASS CIRCUITS
- 4-7-7 MEASURING CUT-OFF FREQUENCY OF HIGHPASS CIRCUITS

## 4-7-2 INITIAL FM/AM-1000S CONTROL SETTING FOR SWEEP GENERATOR/ TRACKING OSCILLOSCOPE OPERATION

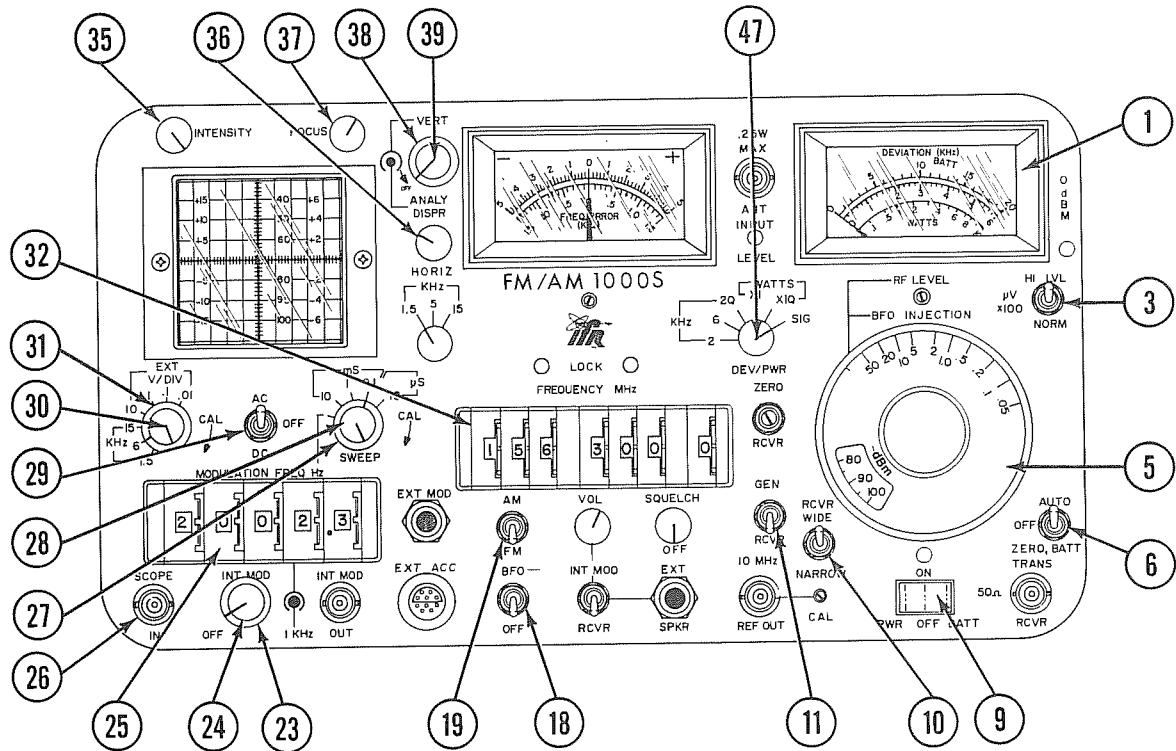

FIGURE 4-30 FM/AM-1000S CONTROLS APPLICABLE TO SWEEP GENERATOR/  
TRACKING OSCILLOSCOPE OPERATION

(Refer to "SECTION 3 - DESCRIPTION OF CONTROLS, CONNECTORS & INDICATORS" for functional description of any controls used in this section.)

### NOTE

- Before performing any procedures contained in this section pertaining to sweep generator/tracking oscilloscope operation, make sure all applicable test set controls are positioned as outlined below.
- Some of the control settings outlined below may be changed during the course of a given procedure; all controls, however, should be reset to initial positions described below when starting a new procedure.

CONTROL	INITIAL SETTING
3 HI LVL/ $\mu$ V X 100/NORM Switch	"HI LVL" position
5 RF LEVEL/BFO INJECTION Dial	Fully ccw
6 AUTO/OFF/ZERO, BATT Switch	"AUTO" position
9 PWR/OFF/BATT Switch	"OFF" position
10 RCVR WIDE/MID/NARROW Switch	"MID" position
11 GEN/RCVR Switch	"GEN" position
18 BFO/OFF Switch	"OFF" position
19 AM/FM Switch	"FM" position
23 INT MOD Control	Fully ccw, detent (OFF)

#### 4-7-2 INITIAL FM/AM-1000S CONTROL SETTINGS FOR SWEEP GENERATOR/ TRACKING OSCILLOSCOPE OPERATION (CONT'D)

CONTROL	INITIAL SETTING
24 1 kHz INT MOD Control	Fully ccw, detent (OFF)
25 MODULATION FREQ Hz Thumbwheels	20.0 Hz
27 SWEEP Control	"OFF" position
28 SWEEP Vernier Control	Fully cw, detent (in "CAL" position)
29 AC/OFF/DC Switch	"DC" position
30 EXT V/DIV Vernier Control	Fully cw, detent (in "CAL" position)
31 EXT V/DIV Control	".01 V/DIV" position
35 INTENSITY Control	Fully ccw
36 HORIZONTAL Control	Midrange position
37 FOCUS Control	Midrange position
38 VERT Control	Midrange position
39 ANALY DISPR Control	Fully ccw, detent
47 DEV/PWR Control	"20 kHz" position

Other FM/AM-1000S features related to sweep generator/tracking oscilloscope operation, but not requiring an initial setting:

- 1 DEVIATION/WATTS Meter
- 26 SCOPE IN Connector
- 32 FREQUENCY MHz Thumbwheels

The FM/AM-1000S is now ready for sweep generator/tracking oscilloscope operation.

### 4-7-3

TEST PROCEDURE: **USING THE FM/AM-1000S AS A SWEEP GENERATOR AND TRACKING OSCILLOSCOPE**

TEST OBJECTIVE: To display typical frequency response curve of a circuit under test on FM/AM-1000S oscilloscope.

SPECIAL ACCESSORY  
EQUIPMENT REQ'D:

For Circuits Using Detector:

- 1 Positive or negative detector (Hewlett Packard 8471A or similar)
- 1 Coax cable with BNC male connector on both ends
- 2 Oscilloscope probes (1:1). If CUT has terminating connectors, use 50Ω coax cables with appropriate connectors.
- 1 BNC female to female adaptor
- 2 DC blocking capacitors (required only if DC components are present)

For Circuits Using Detector Probe (High Impedance Circuits):

- 1 Oscilloscope probe (1:1). If CUT has terminating connectors, use 50Ω coax cable with appropriate connectors.
- 1 Detector probe
- 1 DC blocking capacitor (required only if DC components are present)

TEST SET-UP  
DIAGRAM:

For Circuits Using Detector:

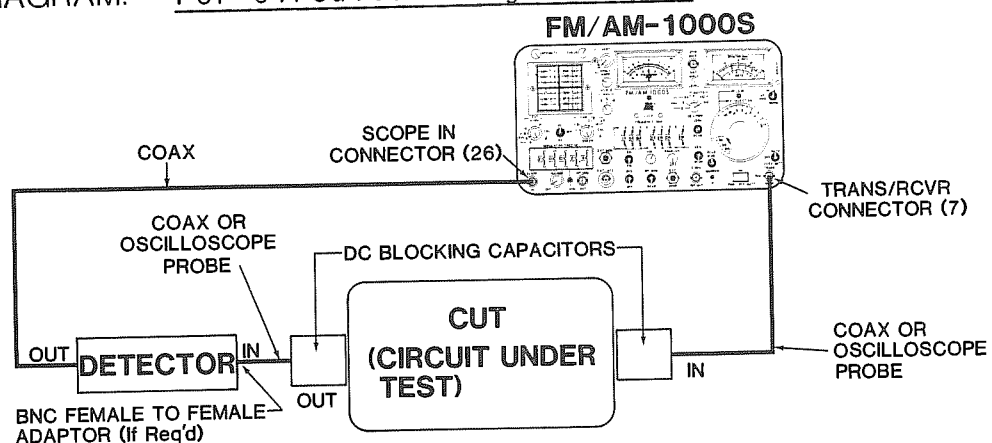

FIGURE 4-31 TEST SET-UP DIAGRAM FOR SWEEP GENERATOR/TRACKING OSCILLOSCOPE OPERATION (USING DETECTOR)

TEST SET-UP  
DIAGRAM: (cont'd)

For Circuits Using Detector Probe (High Impedance  
Circuits):

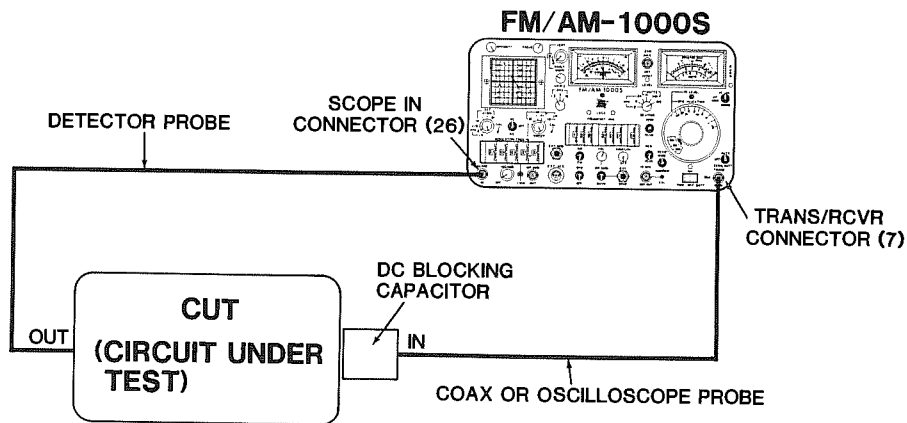

FIGURE 4-32 TEST SET-UP DIAGRAM FOR SWEEP GENERATOR/TRACKING OSCILLOSCOPE OPERATION (USING DETECTOR PROBE)

- | STEP | PROCEDURE  |
|------|--|
| 1.   | Set FM/AM-1000S controls for sweep generator/tracking oscilloscope operation as shown in Figure 4-30, page 4-79.                 |
| 2.   | Connect FM/AM-1000S to circuit under test (CUT) and required test accessories as shown in appropriate test set-up diagram above. |
| 3.   | Apply power to CUT (if applicable).  |
| 4.   | Apply power to FM/AM-1000S.  |
| 5.   | Adjust INTENSITY Control (35) and FOCUS Control (37) for a sharp visible dot on CRT.   |

## STEP

## PROCEDURE

6. Adjust VERT Control (38) and HORIZ Control (36) to position dot three graticule divisions above or below major horizontal axis, along major vertical axis.

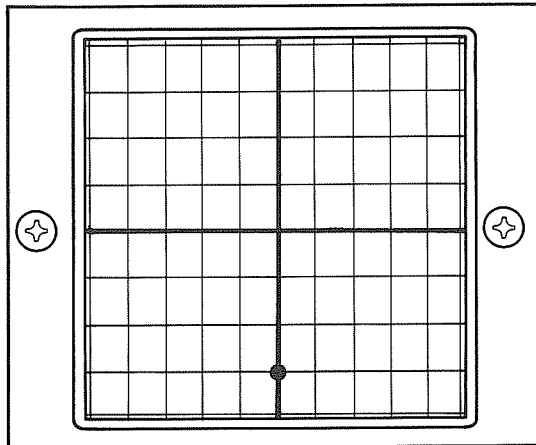

USING POSITIVE DETECTOR

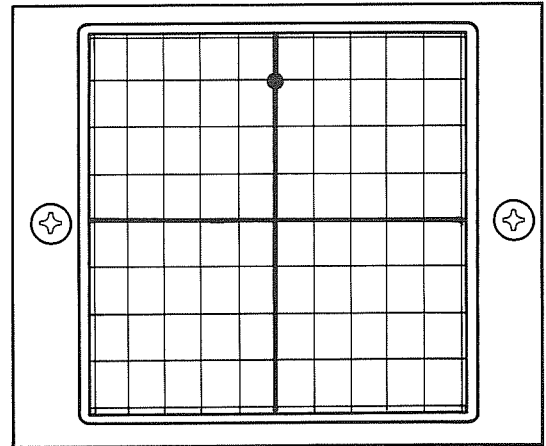

USING NEGATIVE DETECTOR

**FIGURE 4-33 DOT POSITIONED 3 GRATICULE DIVISIONS ABOVE OR BELOW MAJOR HORIZONTAL AXIS, ON MAJOR VERTICAL AXIS**

7. Rotate INT MOD Control (23) cw until deviation reading on DEVIATION/WATTS Meter (1) is 20 kHz. Dot on CRT will now become a horizontal trace.

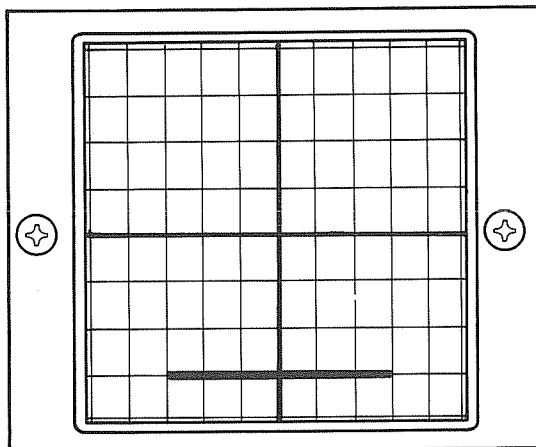

USING POSITIVE DETECTOR

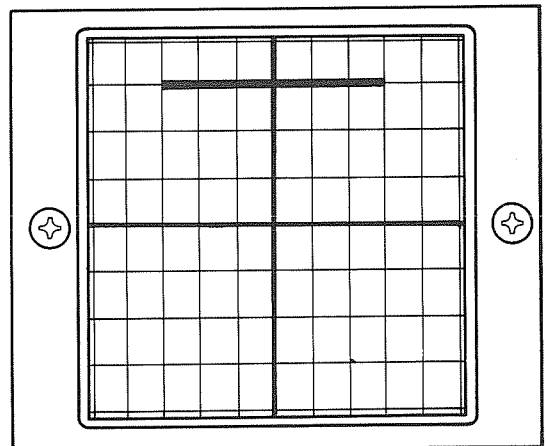

USING NEGATIVE DETECTOR

**FIGURE 4-34 HORIZONTAL TRACE POSITIONED 3 GRATICULE DIVISIONS ABOVE OR BELOW MAJOR HORIZONTAL AXIS, CENTERED OVER MAJOR VERTICAL AXIS.**

8. If trace exhibits any vertical components (i.e. noise), rotate EXT V/DIV Control (31) to ".1 volts/div" position to eliminate those components.
9. Set FREQUENCY MHz Thumbwheels (32) to center of frequency to be swept.



STEP

PROCEDURE

10. Rotate RF LEVEL/BFO INJECTION Dial (5) cw until peak of displayed waveform rests on major horizontal axis.

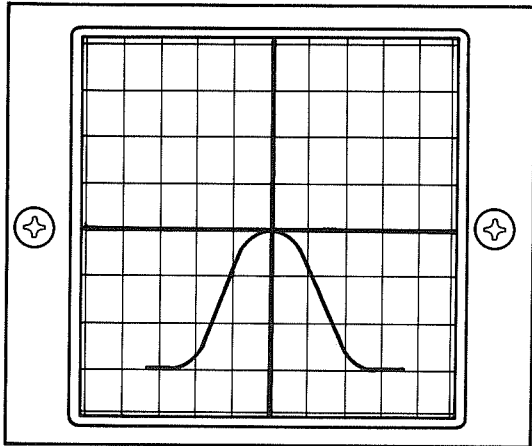

USING POSITIVE DETECTOR

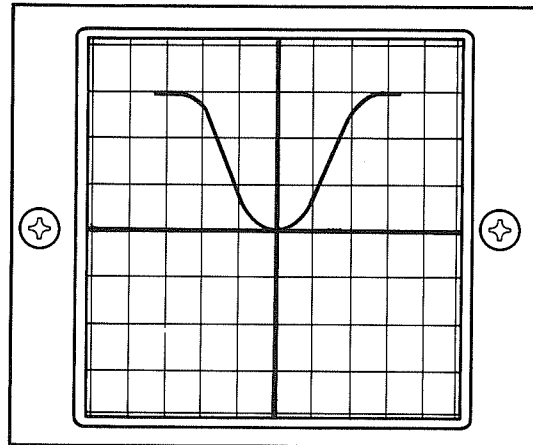

USING NEGATIVE DETECTOR

FIGURE 4-35 PEAK OF DISPLAYED WAVEFORM RESTING ON MAJOR HORIZONTAL AXIS

11. Rotate RF LEVEL/BFO INJECTION Dial (5) cw to add 3 dB to signal strength. Oscilloscope is now displaying frequency response curve of CUT. The major horizontal axis on CRT now represents -3 dB point (or half power point) of CUT.

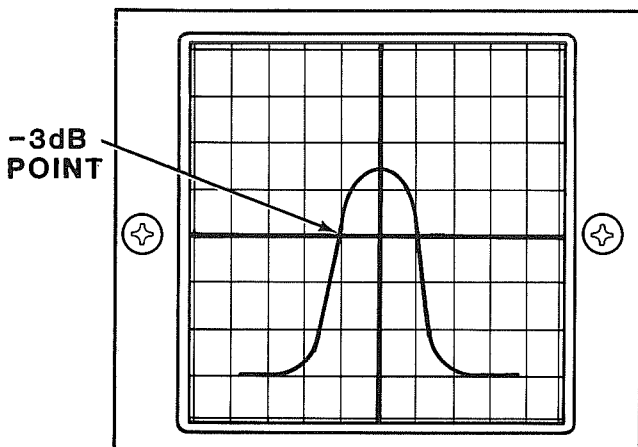

USING POSITIVE DETECTOR

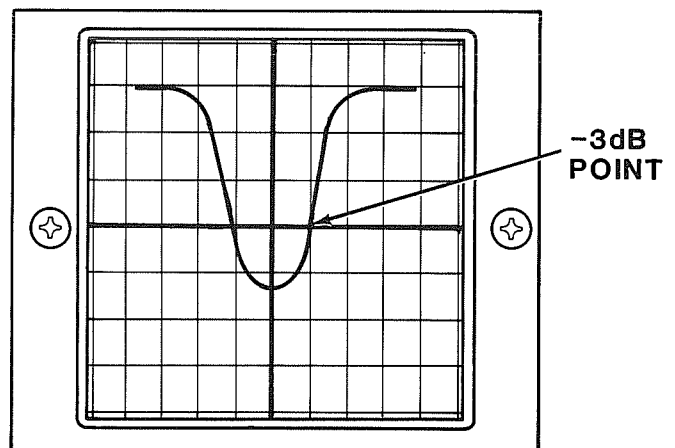

USING NEGATIVE DETECTOR

FIGURE 4-36 FREQUENCY RESPONSE OF CURVE OF CUT

STEP

PROCEDURE

11. (cont'd)

**NOTE**

- If the 3 dB point above major horizontal axis (below axis when using negative detector) cannot be achieved because of significant attenuation, repeat Step 10 until peak of displayed waveform is aligned with any other horizontal graticule marking above or below major horizontal axis. After repeating Step 11, selected horizontal marking will represent the -3 dB point (or half power point) of frequency response curve.



#### 4-7-5

TEST PROCEDURE: **MEASURING BANDPASS AND CENTER FREQUENCY OF A BANDPASS CIRCUIT**

TEST OBJECTIVE: N/A

SPECIAL ACCESSORY  
EQUIPMENT REQ'D: N/A

TEST SET-UP  
DIAGRAM: N/A

- | STEP | PROCEDURE   |
|------|---|
| 1.   | Perform procedure 4-7-3, titled "USING THE FM/AM-1000S AS A SWEEP GENERATOR AND TRACKING OSCILLOSCOPE", on page 4-81.     |
| 2.   | Increment or decrement FREQUENCY MHz Thumbwheels (32) to center peak of bandpass response curve over major vertical axis. |

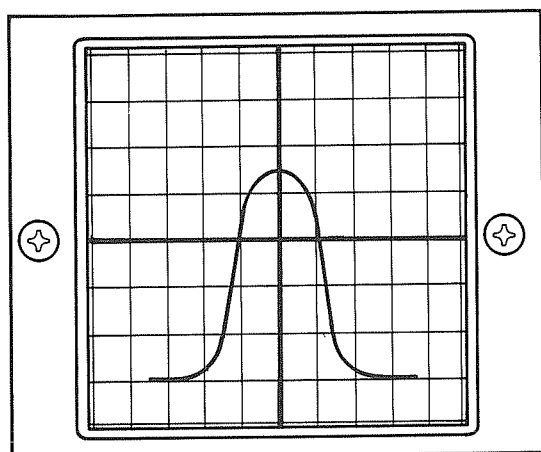

USING POSITIVE DETECTOR

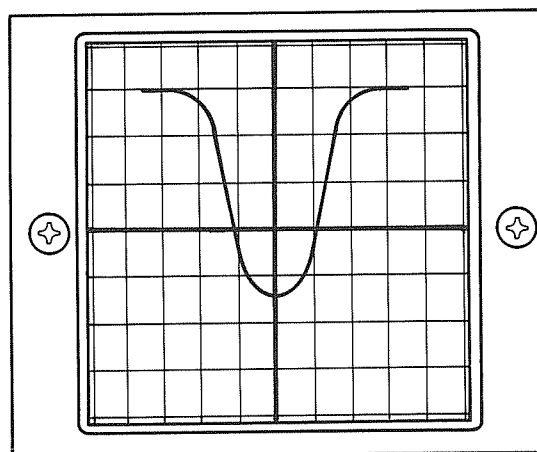

USING NEGATIVE DETECTOR

FIGURE 4-37 BANDPASS RESPONSE CURVE CENTERED OVER MAJOR VERTICAL AXIS

3. Rotate INT MOD Control (23) ccw until one leg of frequency response curve rests on major horizontal axis.

#### NOTE

- Bandpass response curve may not be totally symmetrical after completing this step (i.e. one leg of curve may be longer than the other).

STEP

PROCEDURE

3. (cont'd)

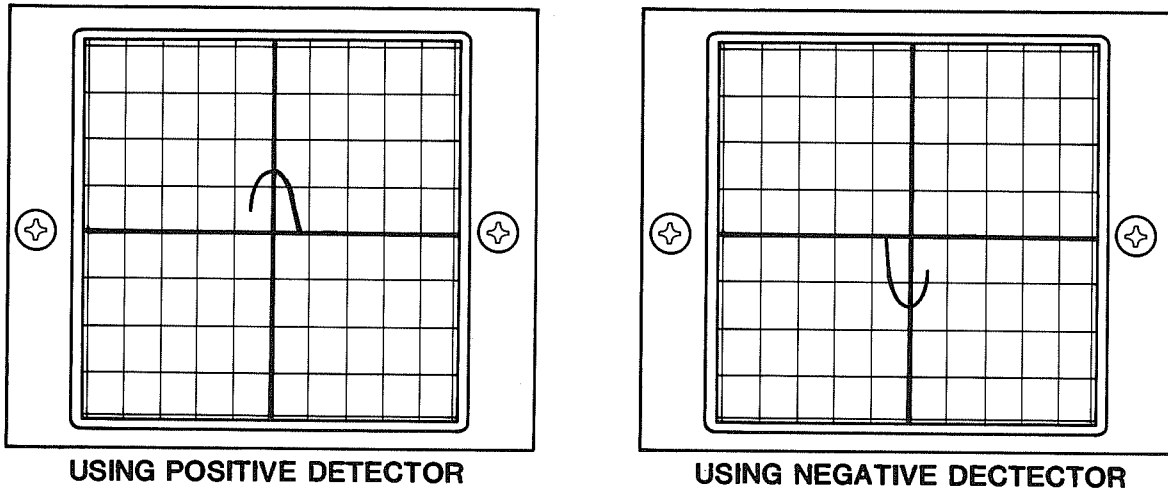

**FIGURE 4-38 BANDPASS RESPONSE CURVE WITH ONE LEG RESTING ON MAJOR HORIZONTAL AXIS**

4. Increment or decrement FREQUENCY MHz Thumbwheels (32) until bandpass response curve becomes symmetrical (both legs of curve of equal length).

**NOTE**

- Legs of frequency response curve may not rest on major horizontal axis after completion of this step.

Present setting of FREQUENCY MHz Thumbwheels (32) represent center frequency of CUT. Record setting.

## STEP

## PROCEDURE

5. Rotate INT MOD Control (23) cw until legs of bandpass response curve again rest on major horizontal axis. The intersection of response curve with major horizontal axis represents -3 dB point (or half power point) of the response curve.

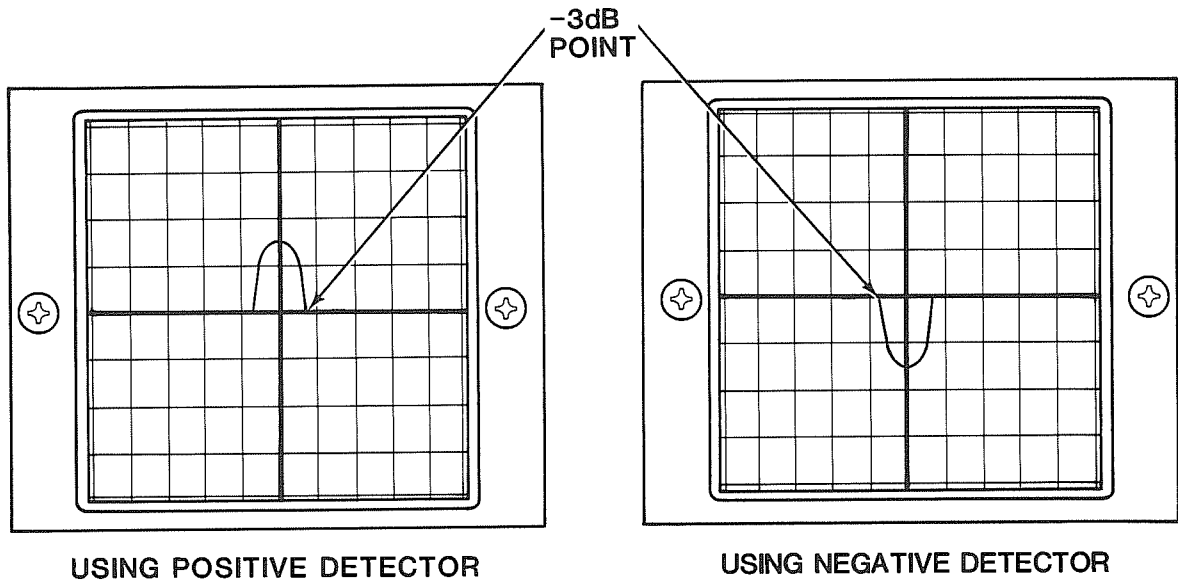

**FIGURE 4-39 BANDPASS RESPONSE CURVE WITH LEGS RESTING ON MAJOR HORIZONTAL AXIS**

6. To determine bandpass of CUT, observe reading of DEVIATION/WATTS Meter (1):
- a. If reading on uppermost scale of meter is less than 6 kHz, rotate DEV/PWR Control (47) to "6 kHz" position and proceed to Step 6b. If reading is above 6 kHz, proceed directly to Step 6c.
  - b. If reading on middle scale of meter is less than 2 kHz, rotate DEV/PWR Control (47) to "2 kHz" position and proceed to Step 6c. If reading is above 2 kHz, proceed directly to Step 6c.
  - c. Record reading of meter; multiply result by 2 to obtain bandpass of CUT in kHz.



## 4-7-5

TEST PROCEDURE: **MEASURING BANDREJECT AND CENTER FREQUENCY OF KNOTCH CIRCUITS**

TEST OBJECTIVE: N/A

SPECIAL ACCESSORY  
EQUIPMENT REQ'D: N/A

TEST SET-UP  
DIAGRAM: N/A

- | STEP | PROCEDURE  |
|------|--|
| 1.   | Perform procedure 4-7-3, titled "USING THE FM/AM-1000S AS A SWEEP GENERATOR AND TRACKING OSCILLOSCOPE", on page 4-81.        |
| 2.   | Increment or decrement FREQUENCY MHz Thumbwheels (32) to center peak of bandreject response curve along major vertical axis. |

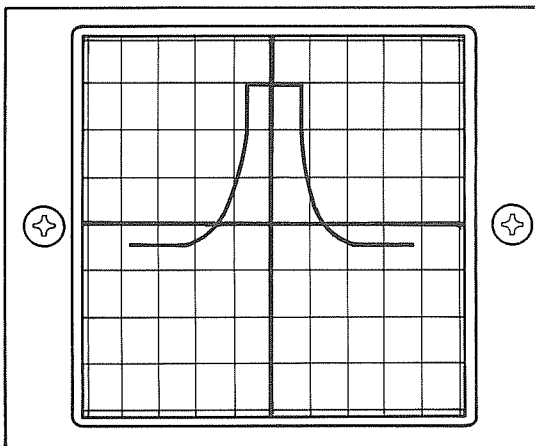

USING NEGATIVE DETECTOR

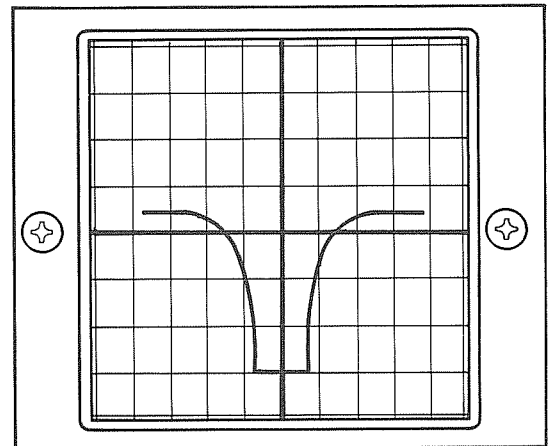

USING POSITIVE DETECTOR

**FIGURE 4-40 BANDREJECT RESPONSE CURVE CENTERED OVER MAJOR VERTICAL AXIS**

3. Rotate INT MOD Control (23) ccw until one leg of frequency response curve rests on major horizontal axis.

### NOTE

- Bandreject response curve may not be totally symmetrical after completing this step (i.e. one leg of curve may be longer than the other).



## STEP

## PROCEDURE

3. (cont'd)

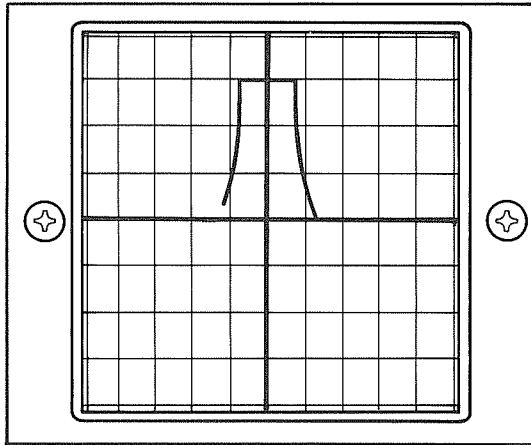

USING NEGATIVE DETECTOR

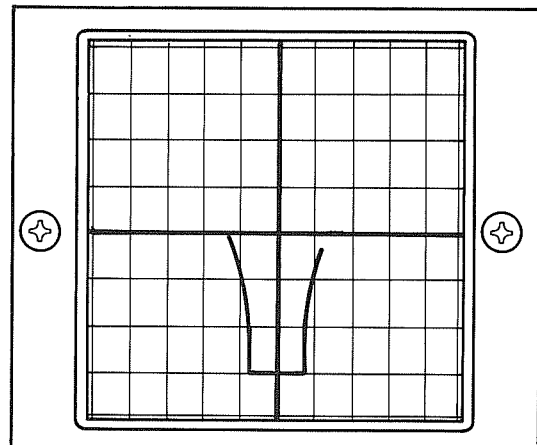

USING POSITIVE DETECTOR

**FIGURE 4-41 BANDREJECT RESPONSE CURVE WITH ONE LEG RESTING ON MAJOR HORIZONTAL AXIS**

4. Increment or decrement FREQUENCY MHz Thumbwheels (32) until bandreject response curve becomes symmetrical (both legs of curve of equal length).

**NOTE**

- Legs of frequency response curve may not rest on major horizontal axis after completion of this step.

Present setting of FREQUENCY MHz Thumbwheels (32) represents center frequency of CUT. Record setting.

5. Rotate INT MOD Control (23) cw until legs of bandreject response curve again rest on major horizontal axis. The intersection of the response curve with major horizontal axis represents -3 dB point (or half power point) of the response curve.

## STEP

## PROCEDURE

5. (cont'd)

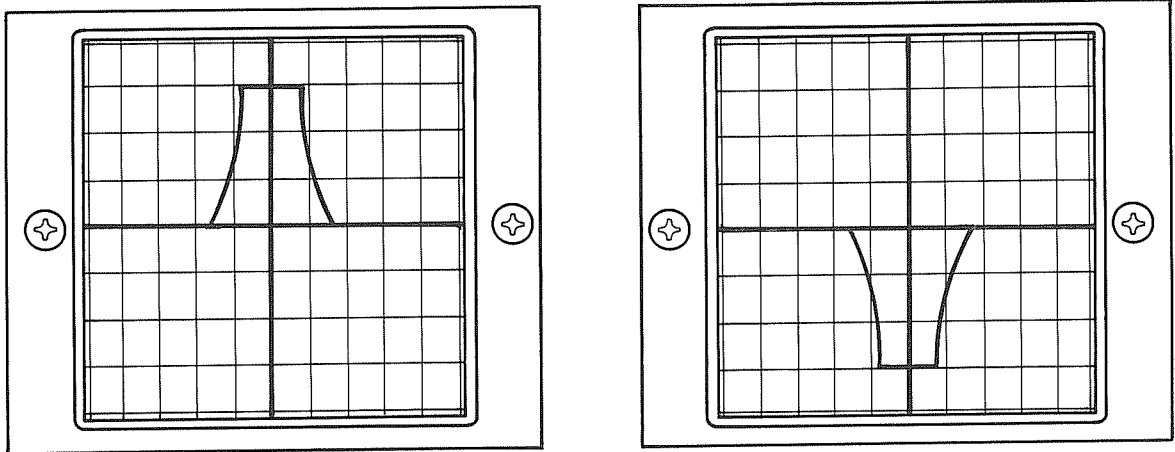

FIGURE 4-42 BANDREJECT RESPONSE CURVE WITH LEGS RESTING ON MAJOR HORIZONTAL AXIS

6. To determine bandreject of CUT, observe reading of DEVIATION/WATTS Meter (1):
- If reading on uppermost scale of meter is less than 6 kHz, rotate DEV/PWR Control (47) to "6 kHz" position and proceed to Step 6b. If reading is above 6 kHz, proceed directly to Step 6c.
  - If reading on middle scale is less than 2 kHz, rotate DEV/PWR Control (47) to "2 kHz" position and proceed to Step 6c. If reading is above 2 kHz, proceed directly to Step 6c.
  - Record reading of meter; multiply result by 2 to obtain bandreject of CUT in kHz.



## 4-7-6

TEST PROCEDURE: **MEASURING CUT-OFF FREQUENCY OF LOWPASS CIRCUITS**

TEST OBJECTIVE: N/A

SPECIAL ACCESSORY  
EQUIPMENT REQ'D:

For Circuits Using Detector:

- 1 Positive or negative detector (Hewlett Packard 8471A or similar)
- 1 Coax cable with BNC male connector on both ends
- 2 Oscilloscope probes (1:1). If CUT has terminating connectors, use  $50\Omega$  coax cables with appropriate connectors.
- 1 BNC female to female adaptor
- 2 DC blocking capacitors (required only if DC components are present)

For Circuits Using Detector Probe (High Impedance Circuits):

- 1 Oscilloscope probe (1:1). If CUT has terminating connectors, use  $50\Omega$  coax cable with appropriate connectors
- 1 Detector probe
- 1 DC blocking capacitor (required only if DC components are present)

TEST SET-UP

DIAGRAM: For Circuits Using Detector:

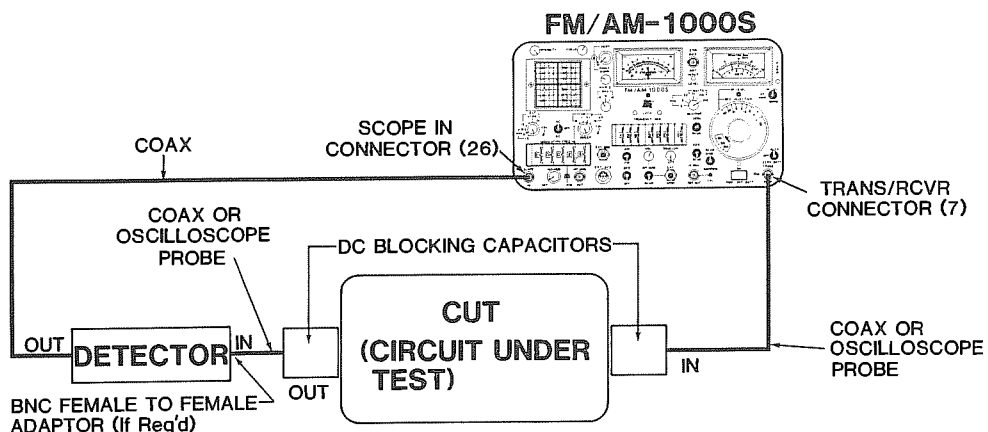

FIGURE 4-43 TEST SET-UP DIAGRAM FOR MEASURING CUT-OFF FREQUENCY OF LOWPASS CIRCUITS (USING DETECTOR)

TEST SET-UP  
 DIAGRAM: For Circuits Using Detector Probes (High Impedance  
 Circuits):

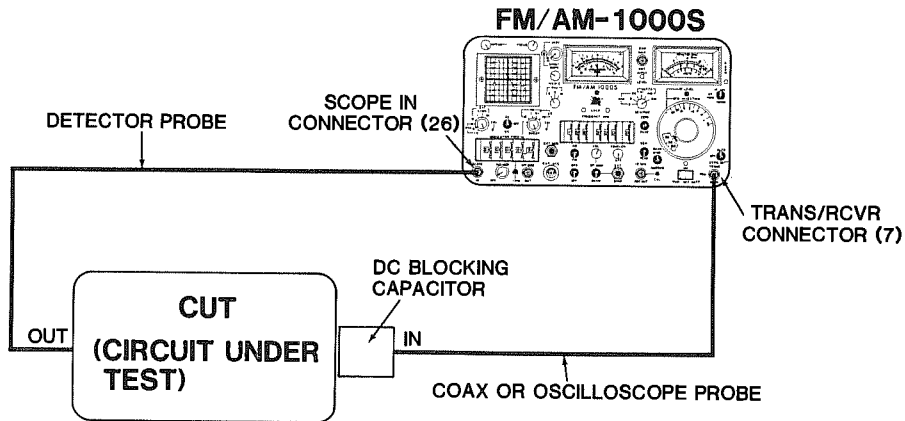

FIGURE 4-44 TEST SET-UP DIAGRAM FOR MEASURING CUT-OFF FREQUENCY OF LOWPASS CIRCUITS (USING DETECTOR PROBE)

- | STEP | PROCEDURE  |
|------|--|
| 1.   | Set FM/AM-1000S controls for sweep generator/tracking oscilloscope operation as shown in Figure 4-30, page 4-79.   |
| 2.   | Connect FM/AM-1000S to circuit under test (CUT) and required test accessories as shown in appropriate test set-up diagram above.                           |
| 3.   | Apply power to CUT (if applicable).  |
| 4.   | Apply power to FM/AM-1000S.  |
| 5.   | Adjust INTENSITY Control (35) and FOCUS Control (37) for a sharp visible dot on CRT.   |
| 6.   | Adjust VERT Control (38) and HORIZ Control (36) to position dot three graticule divisions above or below major horizontal axis, along major vertical axis. |

STEP

PROCEDURE

6. (cont'd)

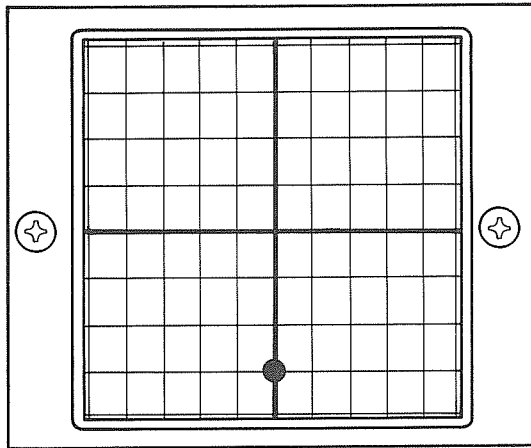

USING POSITIVE DETECTOR

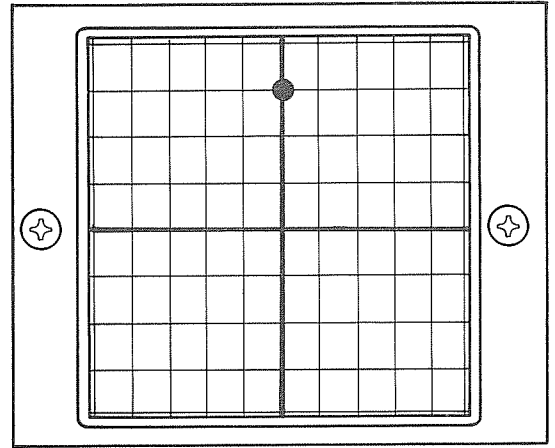

USING NEGATIVE DETECTOR

FIGURE 4-45 DOT POSITIONED 3 GRATICULE DIVISIONS ABOVE OR BELOW MAJOR HORIZONTAL AXIS, CENTERED OVER MAJOR VERTICAL AXIS

7. Rotate INT MOD Control (23) cw until deviation reading on DEVIATION/WATTS Meter (1) is 5 kHz. Dot on CRT will now become a horizontal trace.

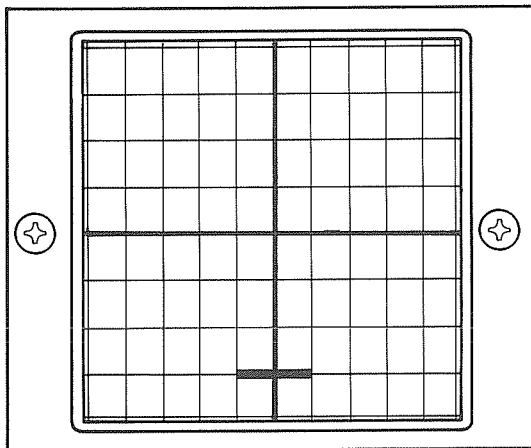

USING NEGATIVE DETECTOR

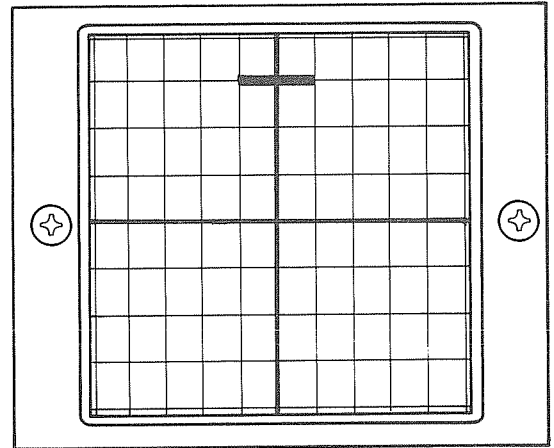

USING POSITIVE DETECTOR

FIGURE 4-46 HORIZONTAL TRACE POSITIONED 3 GRATICULE DIVISIONS ABOVE OR BELOW MAJOR HORIZONTAL AXIS, CENTERED OVER MAJOR VERTICAL AXIS

8. If trace exhibits any vertical components (e.g. noise), rotate EXT V/DIV Control (31) ccw to ".1 volts/div" position to eliminate those components.

- | STEP | PROCEDURE  |
|------|--|
| 9.   | Set FREQUENCY MHz Thumbwheels (32) to a frequency substantially lower than cut-off frequency of CUT. |
| 10.  | Rotate RF LEVEL/BFO INJECTION Dial (5) cw until scope trace becomes aligned with horizontal axis.    |

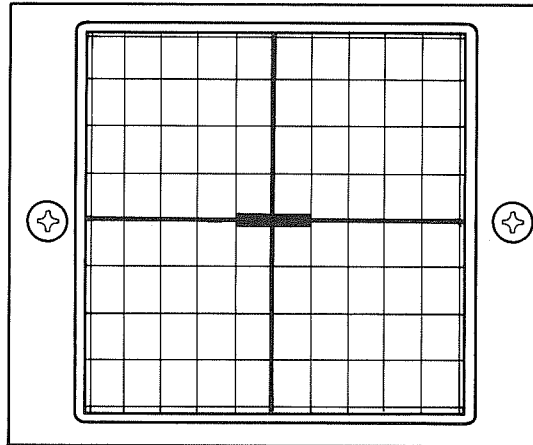

FIGURE 4-47 HORIZONTAL TRACE ALIGNED WITH MAJOR HORIZONTAL AXIS (USING POSITIVE & NEGATIVE DETECTOR)

11. Rotate RF LEVEL/BFO INJECTION Dial (5) cw to add 3 dB to signal strength. The major horizontal axis now represents -3 dB point (or half power point) of CUT.

**NOTE**

- If the 3 dB point above major horizontal axis (below axis when using negative detector) cannot be achieved because of significant attenuation, repeat Step 10 until horizontal trace is aligned with any other horizontal graticule marking above or below major horizontal axis. After repeating Step 11, selected horizontal marking will represent the -3 dB point (or half power point) of frequency response curve.

STEP

PROCEDURE

11. (cont'd)

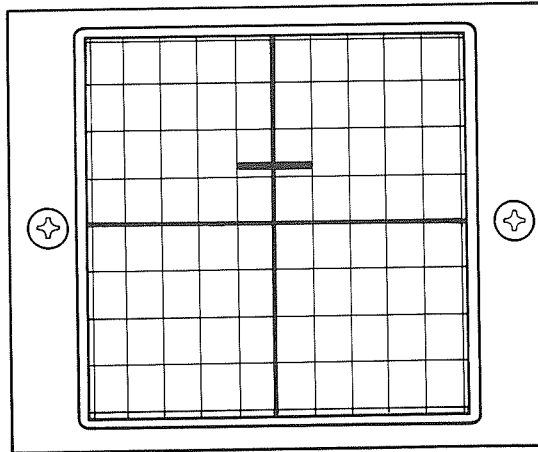

USING POSITIVE DETECTOR

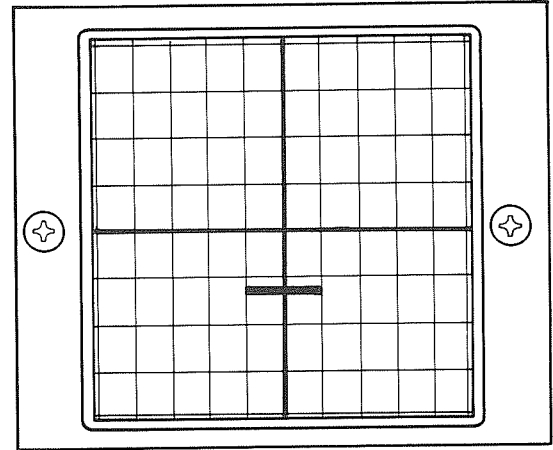

USING NEGATIVE DETECTOR

FIGURE 4-48 POSITION OF HORIZONTAL TRACE AFTER ADDING 3dB TO SIGNAL STRENGTH

12. Set FREQUENCY MHz Thumbwheels (32) to approximate cut-off frequency of CUT.
13. Rotate FREQUENCY MHz Thumbwheels (32) as indicated below to position frequency response curve at point where major vertical and horizontal axes intersect:
  - a. If horizontal trace (or section of frequency response curve) is above a major horizontal axis, increment FREQUENCY MHz Thumbwheels (32).
  - b. If horizontal trace (or section of frequency response curve) is below major horizontal axis, decrement FREQUENCY MHz Thumbwheels (32).

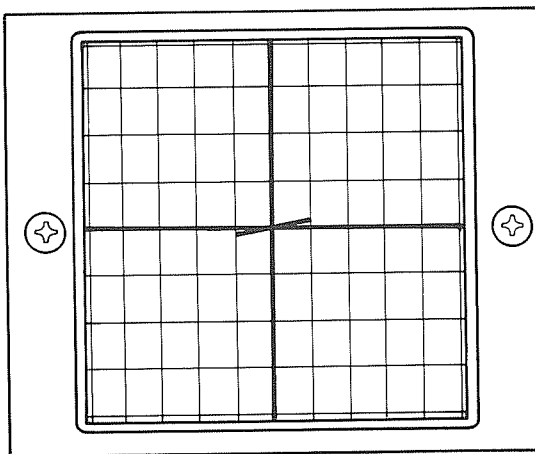

USING POSITIVE DETECTOR

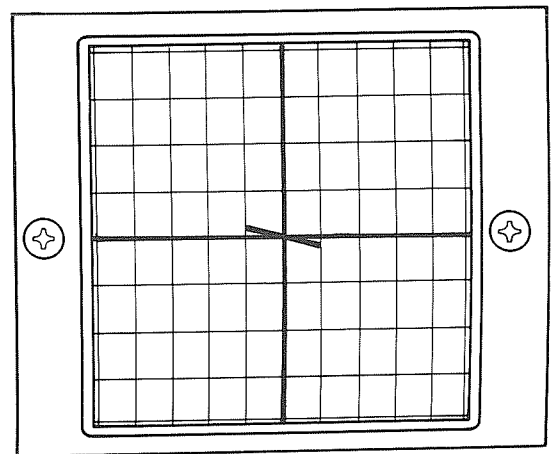

USING NEGATIVE DETECTOR

FIGURE 4-49 HORIZONTAL TRACE (OR SECTION OF FREQUENCY RESPONSE CURVE) POSITIONED AT INTERSECTION OF MAJOR AXIS



STEP

PROCEDURE

14. Present setting of FREQUENCY MHz Thumbwheels represents cut-off frequency of CUT.

4-7-7

TEST PROCEDURE: **MEASURING CUT -OFF FREQUENCY OF HIGH PASS CIRCUITS**

TEST OBJECTIVE: N/A

SPECIAL ACCESSORY  
EQUIPMENT REQ'D:

For Circuits Using Detector:

- 1 Positive or negative detector (Hewlett Packard 8471A or similar)
- 1 Coax cable with BNC male connector on both ends
- 2 Oscilloscope probes (1:1). If CUT has terminating connectors, use 50Ω coax cables with appropriate connectors.
- 1 BNC female to female adaptor
- 2 DC blocking capacitors (required only if DC components are present)

For Circuits Using Detector Probe (High Impedance Circuits):

- 1 Oscilloscope probe (1:1). If CUT has terminating connectors, use 50Ω coax cable with appropriate connectors
- 1 Detector probe
- 1 DC blocking capacitor (required only if DC components are present)

TEST SET-UP

DIAGRAM: For Circuits Using Detector:

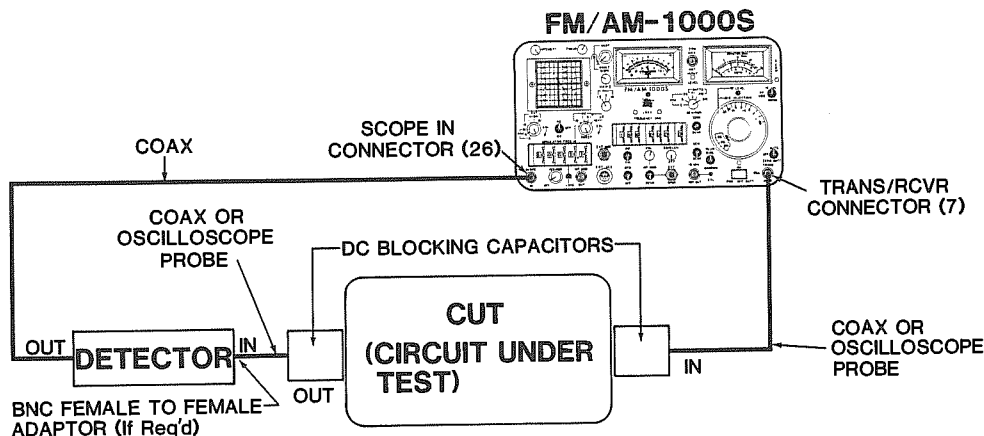

FIGURE 4-50 TEST SET-UP DIAGRAM FOR MEASURING CT CUT-OFF FREQUENCY OF HIGHPASS CIRCUITS (USING DETECTOR)

TEST SET-UP  
 DIAGRAM: For Circuits Using Detector Probe (High Impedance Circuits):

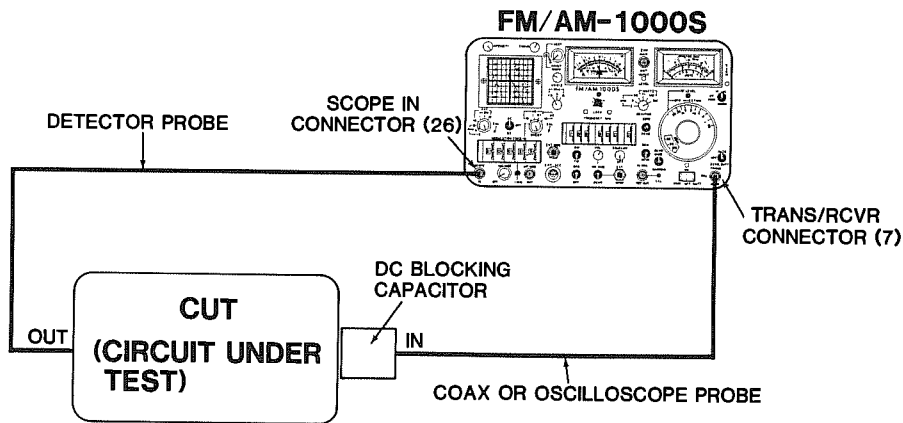

FIGURE 4-51 TEST SET-UP DIAGRAM FOR MEASURING CUT-OFF FREQUENCY OF HIGHPASS CIRCUITS (USING DETECTOR PROBE)

- | STEP | PROCEDURE  |
|------|--|
| 1.   | Set FM/AM-1000S controls for sweep generator/tracking oscilloscope operation as shown in Figure 4-30, page 4-79.   |
| 2.   | Connect FM/AM-1000S to circuit under test (CUT) and required test accessories as shown in appropriate test set-up diagram above.                           |
| 3.   | Apply power to CUT (if applicable).  |
| 4.   | Apply power to FM/AM-1000S.  |
| 5.   | Adjust INTENSITY Control (35) and FOCUS Control (37) for a sharp visible dot on CRT.   |
| 6.   | Adjust VERT Control (38) and HORIZ Control (36) to position dot three graticule divisions above or below major horizontal axis, along major vertical axis. |

STEP

PROCEDURE

6. (cont'd)

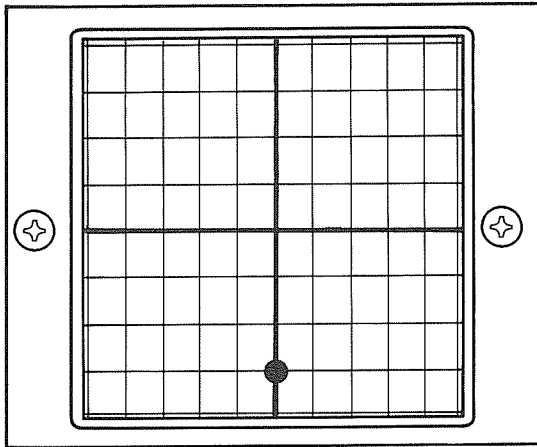

USING POSITIVE DETECTOR

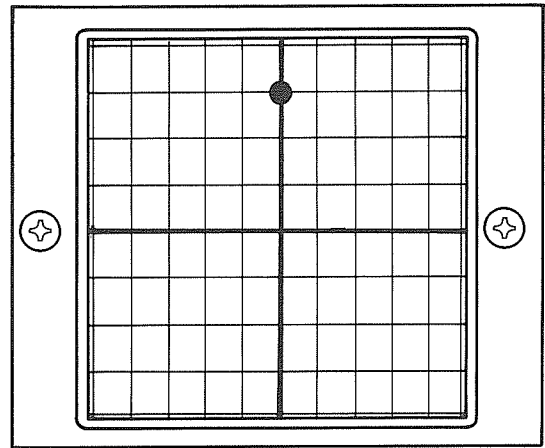

USING NEGATIVE DETECTOR

**FIGURE 4-52 DOT POSITIONED 3 GRAD GRATICULE DIVISIONS ABOVE OR BELOW MAJOR HORIZONTAL AXIS, ON MAJOR VERTICAL AXIS**

7. Rotate INT MOD Control (23) cw until deviation reading on DEVIATION/WATTS Meter (1) is 5 kHz. Dot on CRT will now become a horizontal trace.

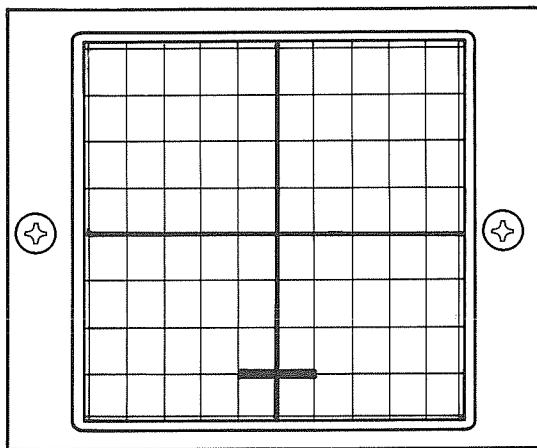

USING POSITIVE DETECTOR

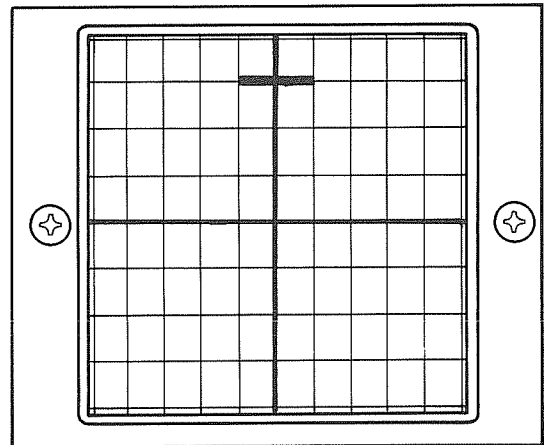

USING NEGATIVE DETECTOR

**FIGURE 4-53 HORIZONTAL TRACE POSITIONED 3 GRATICULE DIVISIONS ABOVE OR BELOW MAJOR HORIZONTAL AXIS, CENTERED OVER MAJOR VERTICAL AXIS**

8. If trace exhibits any vertical components (e.g. noise), rotate EXT V/DIV Control (31) ccw to ".1 volts/div" position to eliminate those components.

## STEP

## PROCEDURE

9. Set FREQUENCY MHz Thumbwheels (32) to a frequency substantially higher than cut-off frequency of CUT.
10. Rotate RF LEVEL/BFO INJECTION Dial (5) cw until scope trace becomes aligned with major horizontal axis.

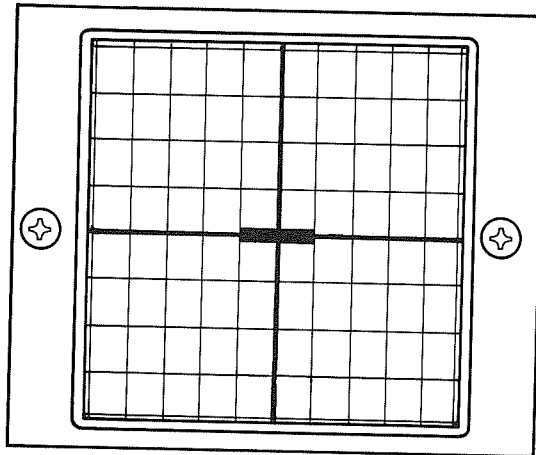

FIGURE 4-54 HORIZONTAL TRACE ALIGNED WITH MAJOR HORIZONTAL AXIS (USING POSITIVE AND NEGATIVE DETECTOR)

11. Rotate RF LEVEL/BFO INJECTION Dial (5) cw to add 3 dBm to signal strength. The major horizontal axis on CRT now represents -3 dB point (or half power point) of CUT.

**NOTE**

- If the 3 dB point above major horizontal axis (below axis when using negative detector) cannot be achieved because of significant attenuation, repeat Step 10 until horizontal trace is aligned with any other horizontal graticule marking above or below major horizontal axis. After repeating Step 11, selected horizontal marking will represent the -3 dB point (or half power point) of frequency response curve.

STEP

PROCEDURE

11. (cont')

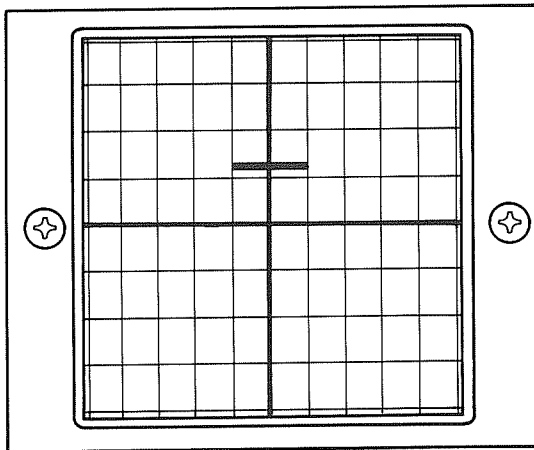

USING POSITIVE DETECTOR

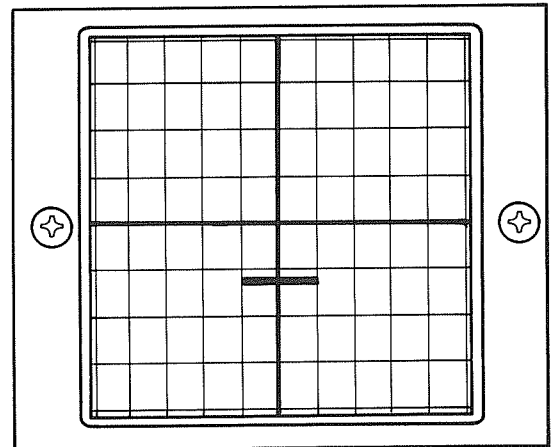

USING NEGATIVE DETECTOR

FIGURE 4-55 POSITION OF HORIZONTAL TRACE AFTER ADDING 3dB

12. Set FREQUENCY MHz Thumbwheels (32) to approximate cut-off frequency of CUT.
13. Rotate FREQUENCY MHz Thumbwheels (32) as indicated below to position frequency response curve at point where major vertical and horizontal axes intersect:
  - a. If horizontal trace (or section of frequency response curve) is above major horizontal axis, decrement FREQUENCY MHz Thumbwheels (32).
  - b. If horizontal trace (or section of frequency response curve) is below major horizontal axis, increment FREQUENCY MHz Thumbwheels (32).

STEP

PROCEDURE

13. (cont'd)

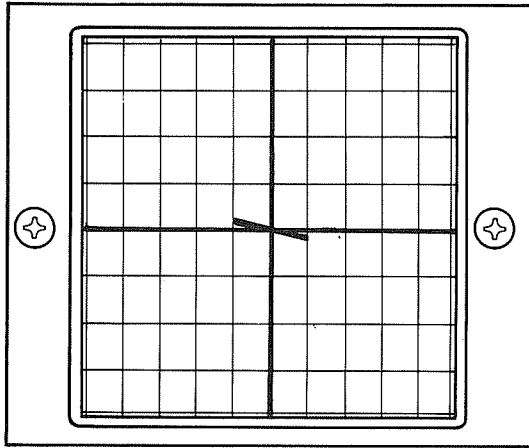

USING POSITIVE DETECTOR

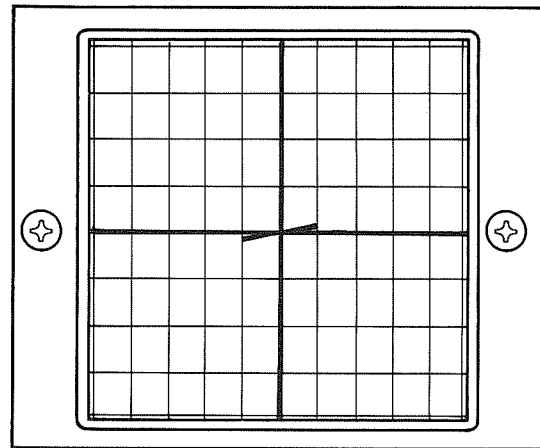

USING NEGATIVE DETECTOR

FIGURE 4-56 HORIZONTAL TRACE (OR SECTION OF FREQUENCY RESPONSE CURVE ) POSITIONED AT INTERSECTION OF MAJOR AXIS.

14. Present setting of FREQUENCY MHz Thumbwheels represents cut-off frequency of CUT.

---

## **4-8 GENERAL RECEIVER TESTS**



## 4-8-1 GENERAL

This section contains an assortment of the more common tests to be used in evaluating AM/FM receiver performance using the FM/AM-1000S. The tests included were selected on the basis of appropriateness, wide ranging applicability and minimal support equipment required to complete the tests. Reference the "RECEIVER ALIGNMENT FLOWCHART" contained in Section 5 of this manual for the recommended sequence in which these tests should be performed.

The test procedures contained in this section are:

### Applicable to AM or FM receivers:

- 4-8-2 OSCILLATOR FREQUENCY MEASUREMENT
- 4-8-3 MEASURING RF SECTION BANDPASS AND CENTER FREQUENCY
- 4-8-4 MEASURING BANDPASS AND CENTER FREQUENCY OF AN IF STRIP
- 4-8-5 MEASURING RECEIVER BANDPASS AND CENTER FREQUENCY (For bandpasses less than 40 kHz)
- 4-8-6 MEASURING RECEIVER BANDPASS AND CENTER FREQUENCY (For bandpasses greater than 40 kHz)
- 4-8-7 MEASURING SQUELCH THRESHOLD AND DIFFERENTIAL (For receivers with fixed squelch control.)
- 4-8-8 MEASURING SQUELCH THRESHOLD AND DIFFERENTIAL (For receivers with variable squelch control.)
- 4-8-9 MEASURING AGC ACTION
- 4-8-10 MEASURING RECEIVER SENSITIVITY

### Applicable to FM receivers only:

- 4-8-11 MEASURING 20 dB QUIETING
- 4-8-12 MEASURING 12 dB SINAD SENSITIVITY
- 4-8-13 MEASURING MAXIMUM RECEIVABLE DEVIATION

## 4-8-2

TEST PROCEDURE: **OSCILLATOR FREQUENCY MEASUREMENT (AM/FM RCVR)**

TEST OBJECTIVE: N/A

SPECIAL ACCESSORY  
EQUIPMENT REQ'D: RF Pickup or "Sniffer" Cable (See Appendix G for  
cable construction procedure.)

TEST SET-UP  
DIAGRAM:

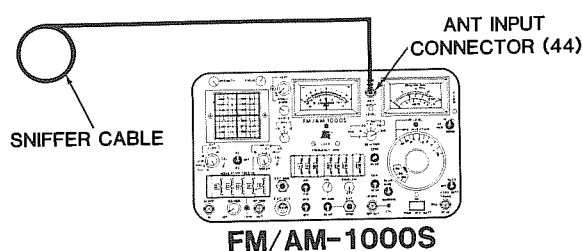

FIGURE 4-57 TEST SET-UP DIAGRAM FOR OSCILLATOR FREQUENCY MEASUREMENT

- | STEP | PROCEDURE  |
|------|--|
| 1.   | Set FM/AM-1000S controls for receiver operation as shown in Figure 4-28, page 4-63.                      |
| 2.   | Set FM/AM-1000S controls for spectrum analyzer operation as shown in Figure 4-16, page 4-33.             |
| 3.   | Apply power to FM/AM-1000S.  |
| 4.   | Adjust INTENSITY Control (35) cw and FOCUS Control (37) appropriately for a sharp visible trace display. |

### NOTE

- Warm-up time of CRT is approximately 30 seconds from a "cold" start-up; trace display will not become visible until CRT achieves warm-up.
5. Set FREQUENCY MHz Thumbwheels (32) within  $\pm 5$  MHz of approximate frequency of local oscillator under test.

## STEP

## PROCEDURE

6. Connect RF pickup or "sniffer" cable to ANT INPUT Connector (44).

**CAUTION**

- MAXIMUM CONTINUOUS INPUT TO THIS CONNECTOR MUST NOT EXCEED .25 W.
  - MAXIMUM INPUT IS -30 dBm FOR PROPER SPECTRUM ANALYZER OPERATION (SIGNALS ABOVE -30 dBm MAY CAUSE SPURIOUS SIGNALS TO BE GENERATED AND DISPLAYED BY FM/AM-1000S.)
7. Place loop of sniffer cable in antenna in close proximity to oscillator being tested in UUT.
8. Rotate ANALY DISPR Control (39) fully ccw and locate oscillator spectrum on spectrum analyzer display.
9. Increment or decrement FREQUENCY MHz Thumbwheels (32) to align oscillator spectrum with major vertical axis.

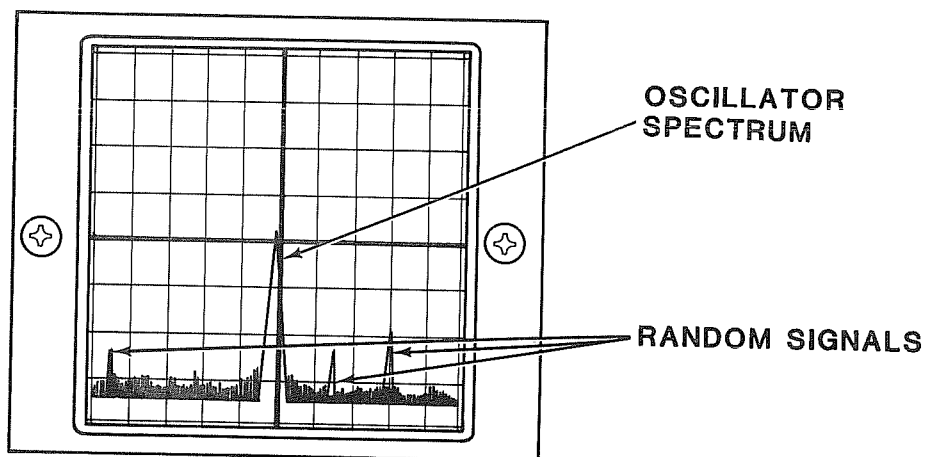

FIGURE 4-58 OSCILLATOR SPECTRUM ALIGNED WITH MAJOR VERTICAL AXIS

10. Shut off power to UUT and observe spectrum analyzer to confirm that the spectrum previously aligned with major vertical axis disappears.
- a. If spectrum disappears when power to UUT is shut off, spectrum is confirmed to be a product of UUT; proceed to Step 13.
  - b. If spectrum does not disappear, its origin is confirmed to be from a source other than UUT; proceed to Step 12.

## STEP

## PROCEDURE

11. Reapply power to UUT and observe spectrums which reappear on spectrum analyzer. Those spectrums which reappear are produced by UUT. Repeat Step 9 to locate and align spectrum of oscillator under test with major vertical axis.
12. Rotate ANALY DISPR Control (39) fully ccw, short of detent position.
13. Realign local oscillator spectrum with major vertical axis by incrementing or decrementing FREQUENCY MHz Thumbwheels (32).
14. While carefully observing FREQ ERROR Meter (41), increment or decrement FREQUENCY MHz Thumbwheels (32) to center FREQ ERROR Meter (41) at zero.
15. Rotate 1.5/5/15 kHz Control (33) to "5 kHz" position and increment or decrement FREQUENCY MHz Thumbwheels (32) to center FREQ ERROR Meter (41) at zero.
16. Rotate 1.5/5/15 kHz Control (33) to "1.5 kHz" position and increment or decrement FREQUENCY MHz Thumbwheels (32) to center FREQ ERROR Meter (41) at zero.
  - a. Present setting of FREQUENCY MHz Thumbwheels (32) represents frequency of oscillator under test.



### 4-8-3

TEST PROCEDURE: **MEASURING RF SECTION BANDPASS AND CENTER FREQUENCY (AM/FM RCVR)**

TEST OBJECTIVE: N/A

SPECIAL ACCESSORY  
EQUIPMENT REQ'D:

For Circuits Using Detector:

- 1 Positive or negative detector (Hewlett Packard 8471A or similar)
- 1 Coax cable with BNC male connector on both ends
- 2 Oscilloscope probes (1:1). If CUT has terminating connectors, use 50Ω coax cables with appropriate connectors.
- 1 BNC female to female adaptor
- 2 DC blocking capacitors (required only if DC components are present)

For Circuits Using Detector Probe (High Impedance Circuits):

- 1 Oscilloscope probe (1:1). If CUT has terminating connectors, use 50Ω coax cable with appropriate connectors
- 1 Detector probe
- 1 DC blocking capacitor (required only if DC components are present)

TEST SET-UP

DIAGRAM: For Circuits Using Detector:

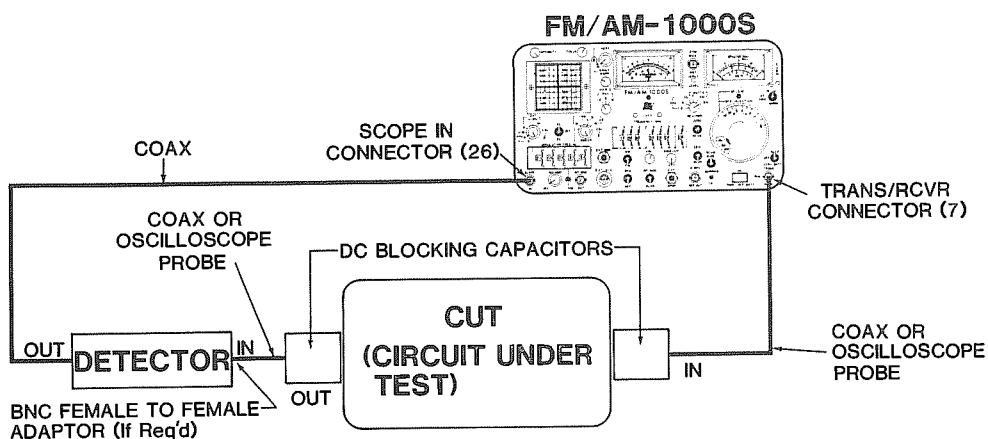

FIGURE 4-59 TEST SET-UP DIAGRAM FOR MEASURING RF SECTION BANDPASS AND CENTER FREQUENCY (USING DETECTOR)

TEST SET-UP  
DIAGRAM: (cont'd)

For Circuits Using Detector Probe (High Impedance  
Circuits):

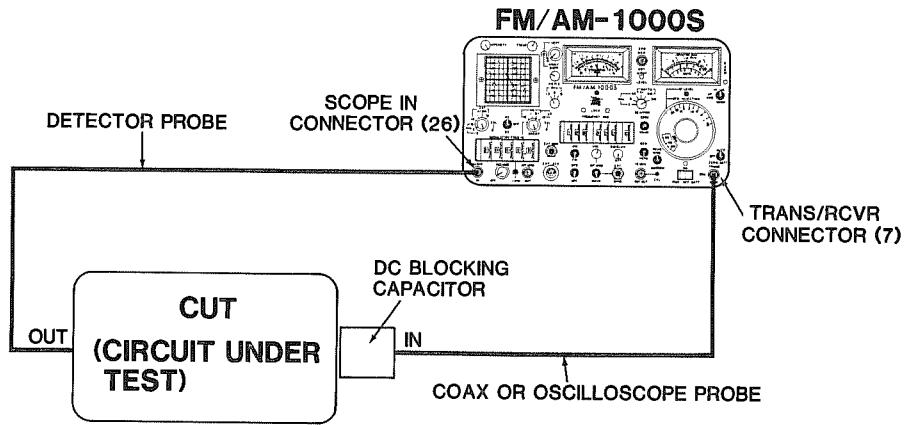

FIGURE 4-60 TEST SET-UP DIAGRAM FOR MEASURING RF SECTION BANDPASS AND CENTER FREQUENCY (USING DETECTOR PROBE)

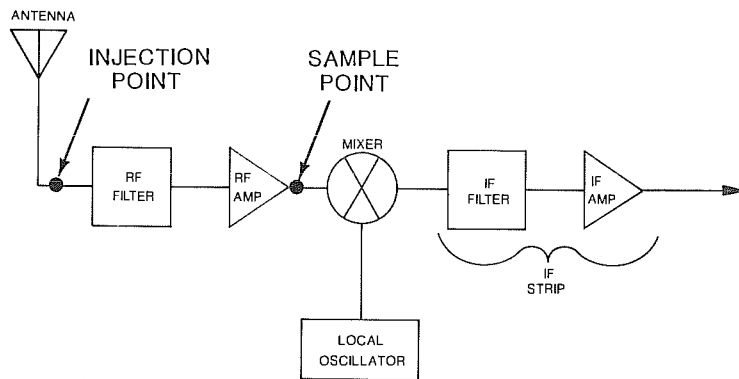

FIGURE 4-61 UUT INJECTION AND SAMPLE POINTS (SINGLE CONVERSION RECEIVER)

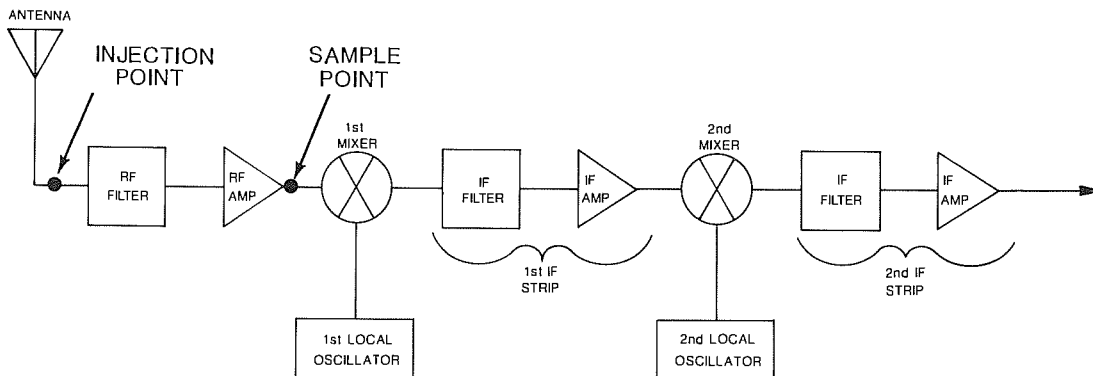
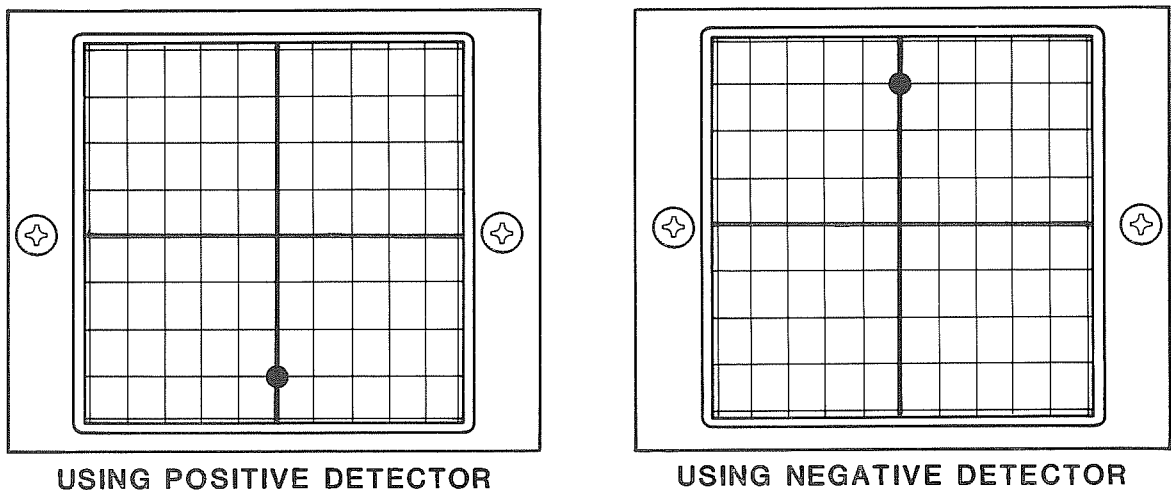

FIGURE 4-62 UUT INJECTION AND SAMPLE POINTS (DUAL CONVERSION RECEIVER)

## STEP

## PROCEDURE

1. Set FM/AM-1000S controls for sweep generator/tracking oscilloscope operation as shown in Figure 4-30, page 4-79.
2. Connect FM/AM-1000S to required test accessory equipment and circuit under test within UUT as shown in appropriate test set-up diagram at beginning of this procedure.
3. Apply power to UUT.
4. Apply power to FM/AM-1000S.
5. Adjust INTENSITY Control (35) and FOCUS Control (37) for a sharp visible dot on CRT.
6. Adjust VERT Control (38) and HORIZ Control (36) to position dot three graticule divisions above or below major horizontal axis, along major vertical axis.



**FIGURE 4-63 DOT POSITIONED 3 GRATICULE DIVISIONS ABOVE OR BELOW MAJOR HORIZONTAL AXIS , ON MAJOR VERTICAL AXIS**

7. Rotate INT MOD Control (23) cw until deviation reading on DEVIATION/WATTS Meter (1) is 5 kHz. Dot on CRT will now become a horizontal trace.
8. If trace exhibits any vertical components (e.g. noise) rotate EXT V/DIV Control (31) ccw to ".1 volts/div" position to eliminate those components.
9. Set FREQUENCY MHz Thumbwheels (32) to center of frequency being swept (approximate center of bandpass).



STEP

PROCEDURE

10. Rotate RF LEVEL/BFO INJECTION Dial (5) cw until trace becomes aligned with major horizontal axis.

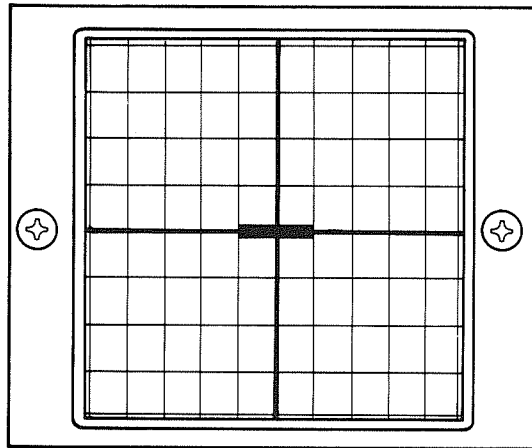

FIGURE 4-64 HORIZONTAL TRACE ALIGNED WITH MAJOR HORIZONTAL AXIS (USING POSITIVE AND NEGATIVE DETECTOR)

11. Rotate RF LEVEL/BFO INJECTION Dial (5) cw to add 3 dB to signal strength. The major horizontal axis now represents the -3 dB point (or half power point) of CUT.

**NOTE**

- If the 3 dB point above major horizontal (below axis when using negative detector) cannot be achieved because of significant attenuation, repeat Step 10 until horizontal trace is aligned with any other horizontal graticule marking above or below major horizontal axis. After repeating Step 11, selected horizontal marking will represent the -3 dB point (or half power point) of frequency response curve.

## STEP

## PROCEDURE

12. Increment FREQUENCY MHz Thumbwheels (32) until horizontal trace is centered at point where major vertical and horizontal axes intersect. Record setting of FREQUENCY MHz Thumbwheels (32).

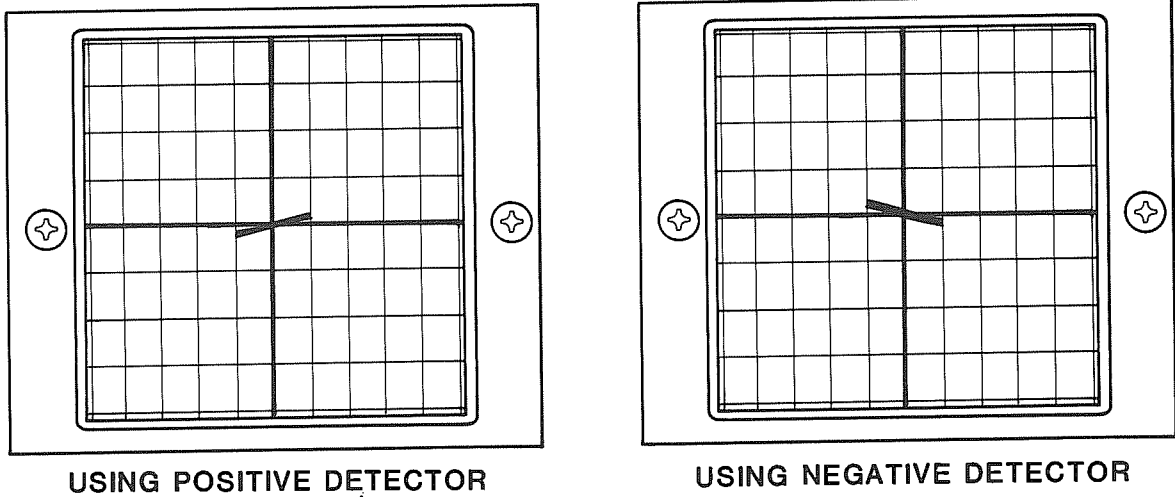

FIGURE 4-65 HORIZONTAL TRACE (OR SECTION OF FREQUENCY RESPONSE CURVE )  
POSITIONED AT INTERSECTION OF MAJOR AXIS

13. Decrement FREQUENCY MHz Thumbwheels (32) until horizontal trace is centered at point where major vertical and horizontal axes intersect. Record setting of FREQUENCY MHz Thumbwheels (32).

**NOTE**

- While performing Step 13, horizontal trace will deviate from intersection of major vertical and horizontal axes before returning to its centered position as shown in Figure 4-66 on following page.

STEP

PROCEDURE

13. (cont'd)

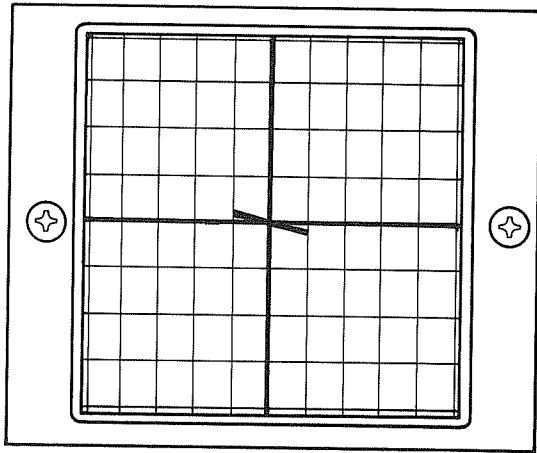

USING POSITIVE DETECTOR

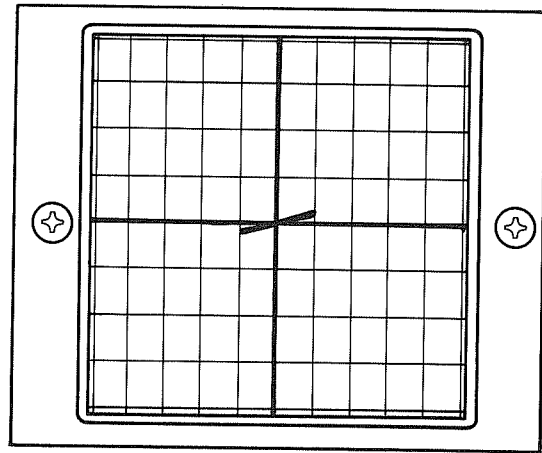

USING NEGATIVE DETECTOR

FIGURE 4-66 HORIZONTAL TRACE (OR SECTION OF FREQUENCY RESPONSE CURVE) POSITIONED AT INTERSECTION OF MAJOR AXIS

14. To determine bandpass of CUT, subtract result of Step 13 from result of Step 12; difference represents bandpass of CUT.
15. To obtain center frequency of CUT, add result of Step 12 to result of Step 13 and divide total by two; quotient represents center frequency of CUT.

4-8-4

TEST PROCEDURE: **MEASURING BANDPASS AND CENTER FREQUENCY OF AN IF STRIP (AM/FM RCVR)**

TEST OBJECTIVE: N/A

SPECIAL ACCESSORY  
EQUIPMENT REQ'D:

Same as required for procedure 4-7-3, titled "USING THE FM/AM-1000S AS A SWEEP GENERATOR/TRACKING OSCILLOSCOPE", on page 4-81.

TEST SET-UP  
DIAGRAM:

Use block diagrams below to locate injection and sample points within a typical UUT.

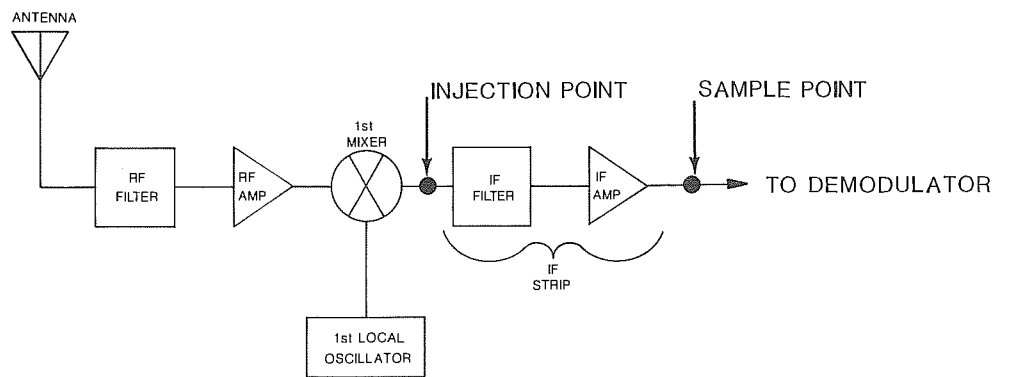

FIGURE 4-67 UUT SAMPLE AND INJECTION POINTS (SINGLE CONVERSION RECEIVER )

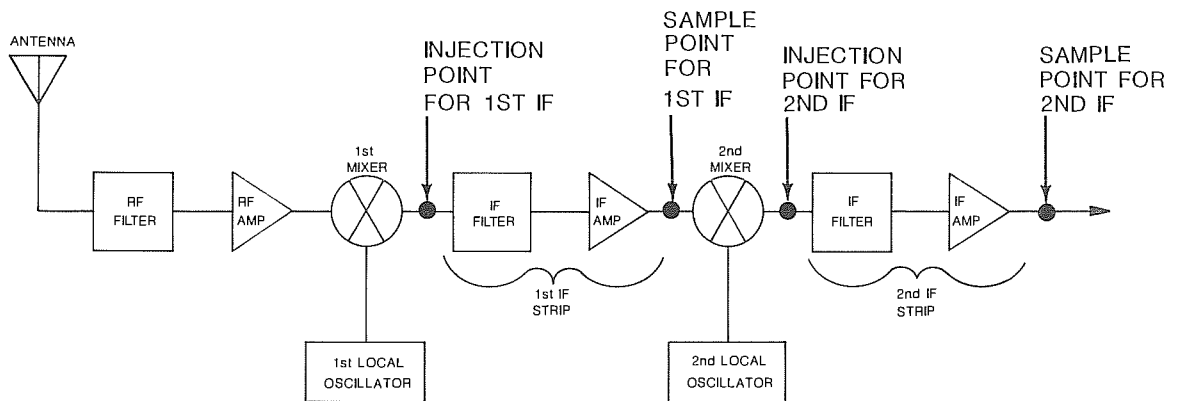

FIGURE 4-68 UUT SAMPLE AND INJECTION POINTS ( DUAL CONVERSION RECEIVER )

## STEP

## PROCEDURE

1. Perform procedure 4-7-4, titled "MEASURING BANDPASS AND CENTER FREQUENCY OF A BANDPASS CIRCUIT", on page 4-87.

**NOTE**

- The circuit under test (CUT) referenced in above procedure is now represented by block diagrams furnished above.
  - Center frequency of span to be swept will be IF frequency of UUT.
2. Return DEV/PWR Control (47) to "20 kHz" position.
  3. Rotate INT MOD Control (23) cw until DEVIATION/WATTS Meter (1) reads 20 kHz.
  4. Observe frequency response curve for good flatness, symmetry and roll-off characteristics.

**NOTE**

- Examples below reflect measurements taken with a positive detector.
- Narrow bandwidth receivers will not exhibit flatness characteristic.

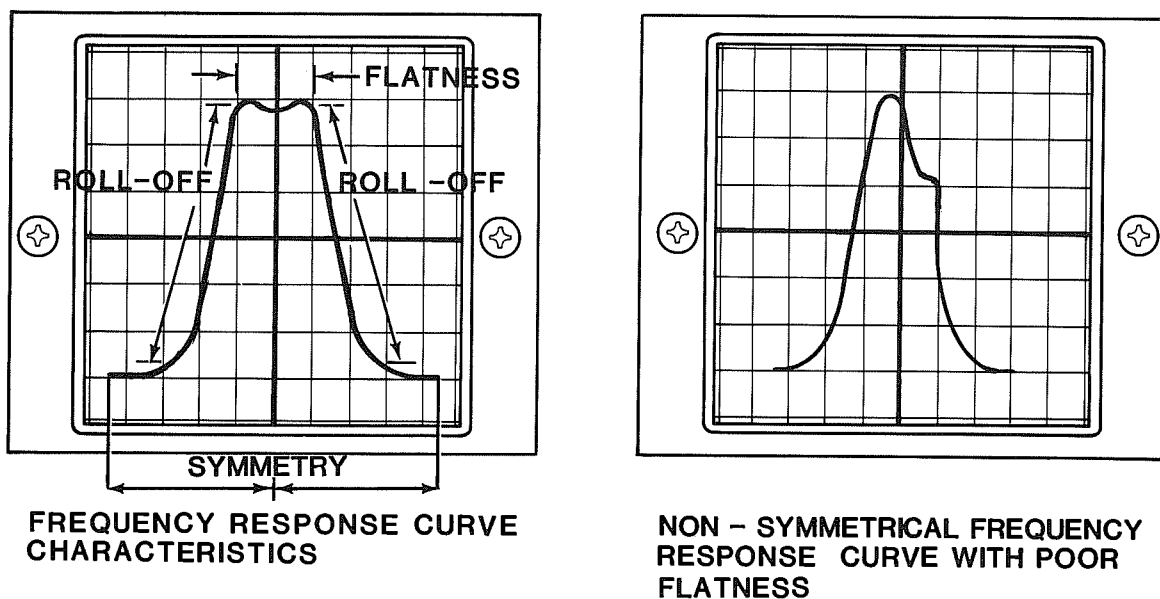
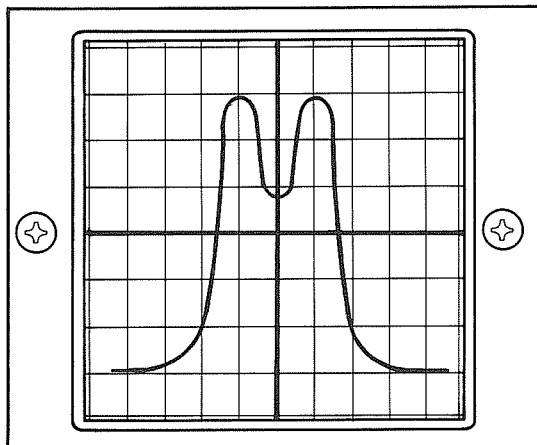

FIGURE 4-69 TYPICAL DISPLAYS OF FREQUENCY RESPONSE CURVE

STEP

PROCEDURE

4. (cont'd)



**SYMMETRICAL FREQUENCY  
RESPONSE CURVE LACKING  
FLATNESS**

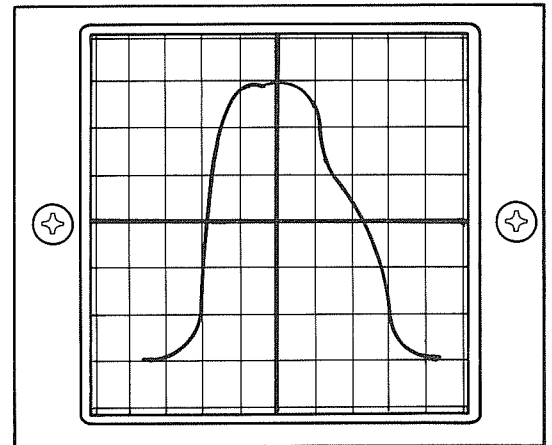

**NON-SYMMETRICAL FREQUENCY  
CURVE WITH POOR ROLL-OFF.**

**FIGURE 4-70 TYPICAL DISPLAYS OF FREQUENCY RESPONSE CURVES**



### 4-8-5

TEST PROCEDURE: **MEASURING RECEIVER BANDPASS AND CENTER FREQUENCY (FOR BANDPASSES LESS THAN 40 kHz)**

TEST OBJECTIVE: N/A

SPECIAL ACCESSORY EQUIPMENT REQ'D: Same as required for procedure 4-7-3, titled "USING THE FM/AM-1000S AS A SWEEP GENERATOR/TRACKING OSCILLOSCOPE", on page 4-81.

TEST SET-UP DIAGRAM: Use block diagrams below to locate injection and sample points within a typical UUT.

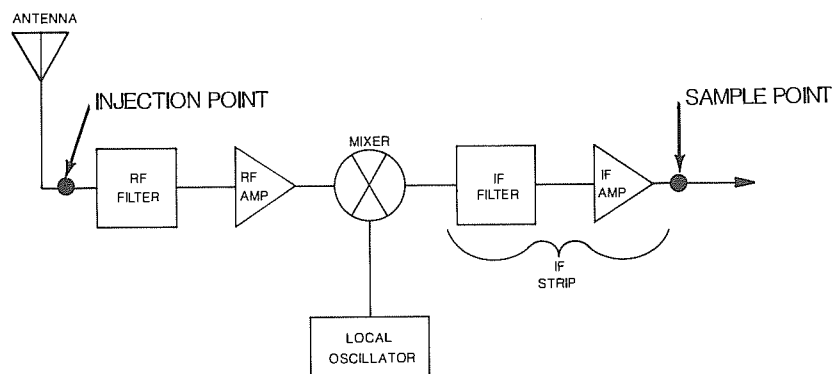

FIGURE 4-71 UUT INJECTION AND SAMPLE POINTS (SINGLE CONVERSION RECEIVER)

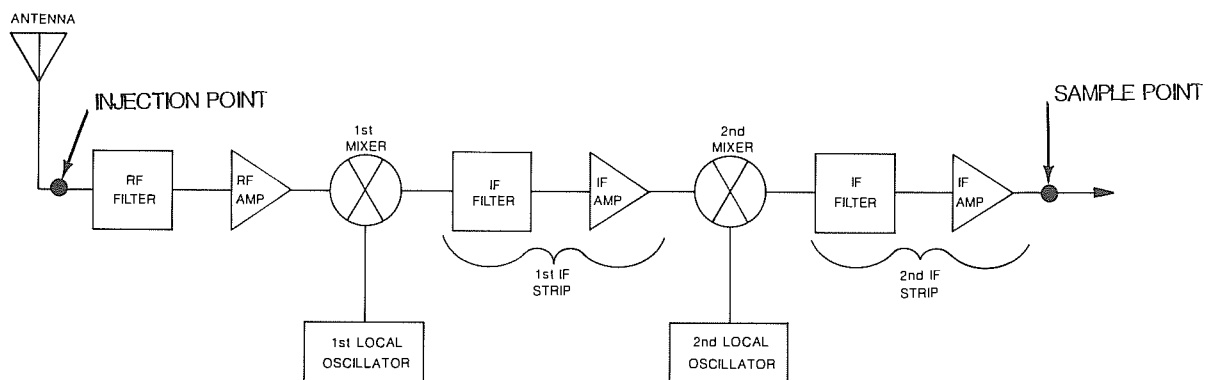

FIGURE 4-72 UUT INJECTION AND SAMPLE POINTS (DUAL CONVERSION RECEIVER)



STEP

PROCEDURE

1. Perform procedure titled 4-7-4, "MEASURING CENTER FREQUENCY AND BANDPASS OF A BANDPASS CIRCUIT", on page 4-87.

**NOTE**

- The circuit under test (CUT) referenced in above procedure is now represented by block diagrams furnished above.
  - Center frequency of span to be swept will be receiver frequency.
2. Return DEV/PWR Control (47) to "20 kHz" position.
  3. Rotate INT MOD Control (23) cw until DEVIATION/WATTS Meter reads "20 kHz."
  4. Observe bandpass response curve for good flatness, symmetry and roll-off characteristics:

**NOTE**

- If frequency of UUT local oscillator is greater than sweep frequency (low side injection), the polarity of CRT display will be reversed; therefore, frequency is minimum on left side of CRT and maximum on right side of CRT.
- Examples below reflect measurements taken with a positive detector.
- Narrow bandwidth receivers will not exhibit flatness characteristic.

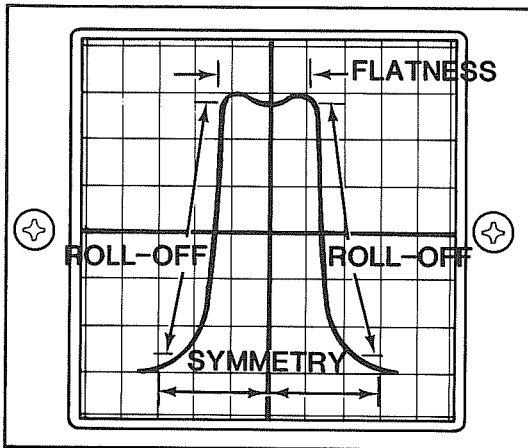

FREQUENCY RESPONSE CHARACTERISTICS

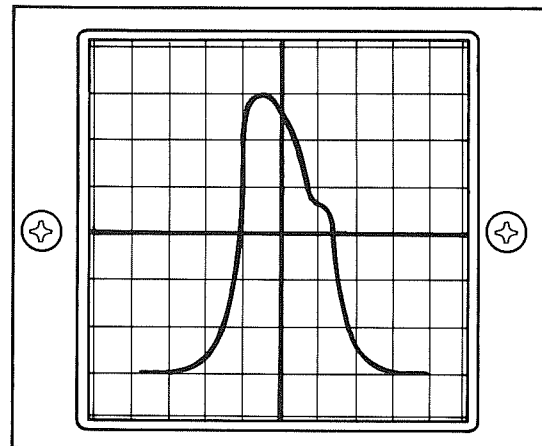

NON-SYMMETRICAL BANDPASS RESPONSE CURVE WITH POOR FLATNESS

FIGURE 4-73 TYPICAL DISPLAYS OF FREQUENCY RESPONSE CURVES FOR AVERAGE BAND RECEIVERS

STEP

PROCEDURE

4. (cont'd)

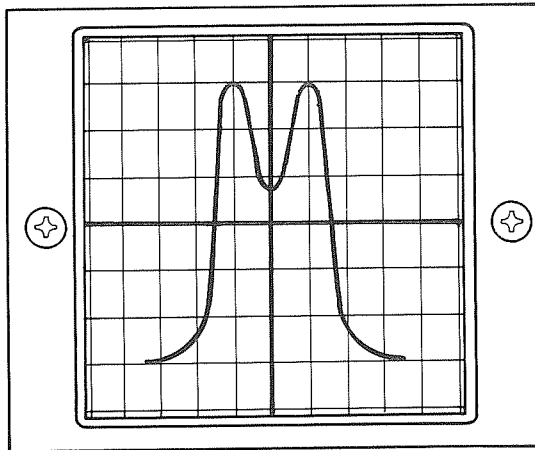

**SYMMETRICAL BANDPASS  
RESPONSE CURVE LACKING  
FLATNESS**

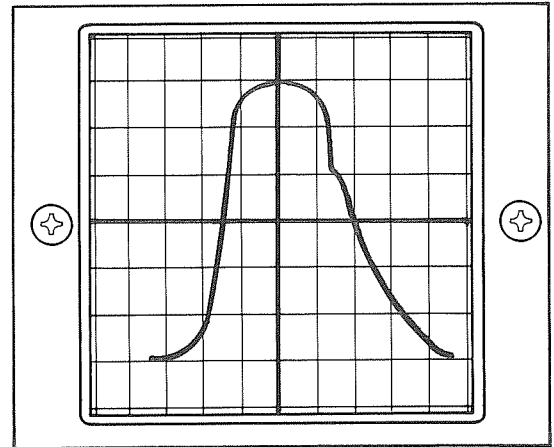

**NON-SYMMETRICAL BANDPASS  
RESPONSE CURVE WITH POOR  
ROLL-OFF**

**FIGURE 4-74 TYPICAL DISPLAYS OF FREQUENCY RESPONSE CURVES  
FOR AVERAGE BAND RECEIVERS**

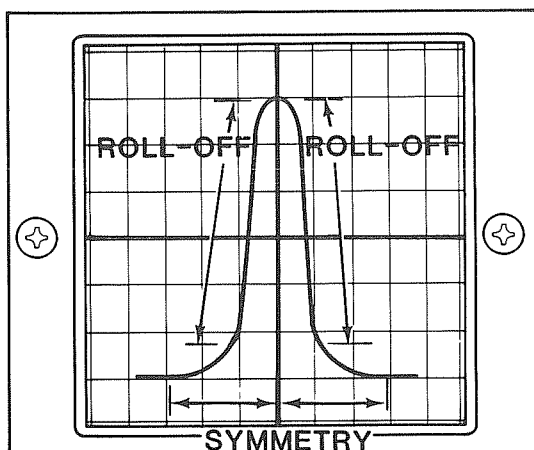

**FREQUENCY RESPONSE CURVE  
CHARACTERISTICS**

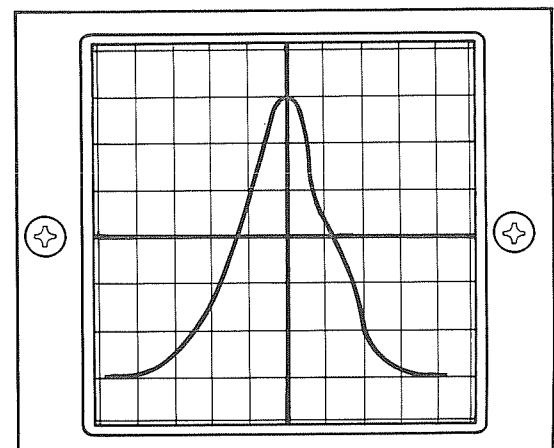

**BANDPASS RESPONSE CURVE  
WITH POOR ROLL-OFF**

**FIGURE 4-75 TYPICAL DISPLAYS OF FREQUENCY RESPONSE  
CURVES FOR NARROW BAND RECEIVERS**

STEP

PROCEDURE

4. (cont'd)

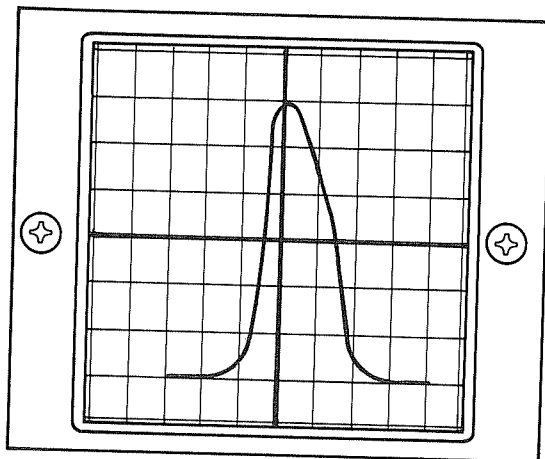

**BANDPASS RESPONSE CURVE  
WITH POOR SYMMETRY**

**FIGURE 4-76 TYPICAL DISPLAY OF FREQUENCY RESPONSE CURVE  
FOR NARROW BAND RECEIVERS**

4-8-6

TEST PROCEDURE: **MEASURING RECEIVER BANDPASS AND CENTER FREQUENCY (FOR AM/FM RECEIVER BANDPASSES GREATER THAN 40 kHz)**

TEST OBJECTIVE: N/A

SPECIAL ACCESSORY EQUIPMENT REQ'D: Same as required for procedure 4-7-3, titled "USING FM/AM-1000S AS A SWEEP GENERATOR/TRACKING OSCILLOSCOPE", on page 4-81.

TEST SET-UP DIAGRAM: Use block diagrams below to locate injection and sample points within a typical UUT.

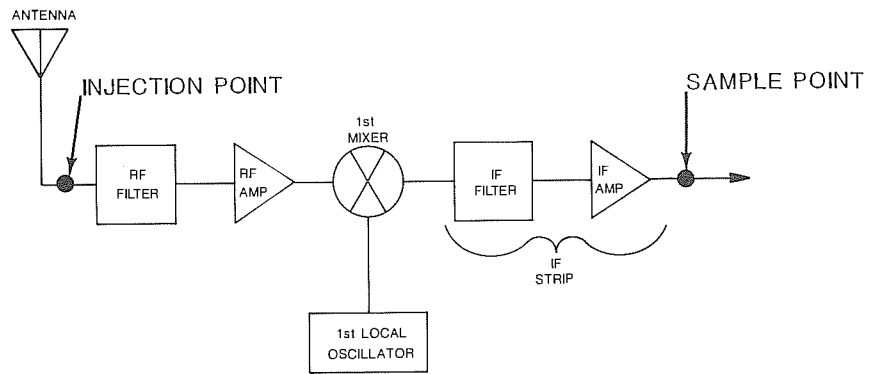

FIGURE 4-77 UUT INJECTION AND SAMPLE POINTS (SINGLE CONVERSION RECEIVER)

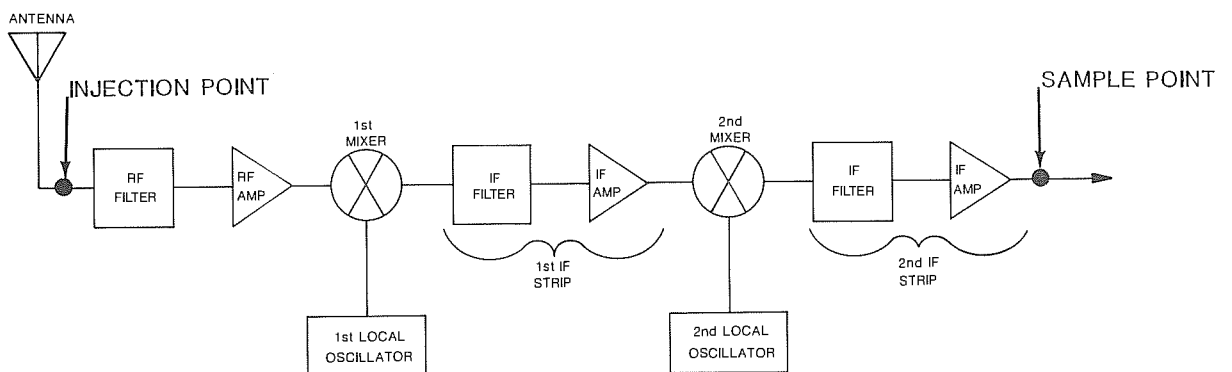

FIGURE 4-78 UUT INJECTION AND SAMPLE POINTS (DUAL CONVERSION RECEIVER)

## STEP

## PROCEDURE

1. Perform Steps 1 through 9 of procedure 4-7-3, titled "USING FM/AM-1000S AS A SWEEP GENERATOR/TRACKING OSCILLOSCOPE", on page 4-81.
2. Rotate RF LEVEL/BFO INJECTION Dial (5) cw until horizontal trace is aligned with major horizontal axis.

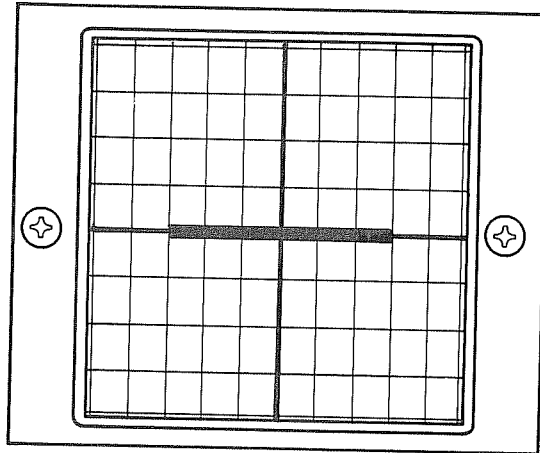

FIGURE 4-79 HORIZONTAL TRACE ALIGNED WITH MAJOR HORIZONTAL AXIS

3. Rotate RF LEVEL/BFO INJECTION Dial (5) cw to add 3 dB to signal strength. Oscilloscope is now displaying a small section of frequency response curve of UUT. The major horizontal axis on CRT now represents -3 dB point (or half power point of UUT).

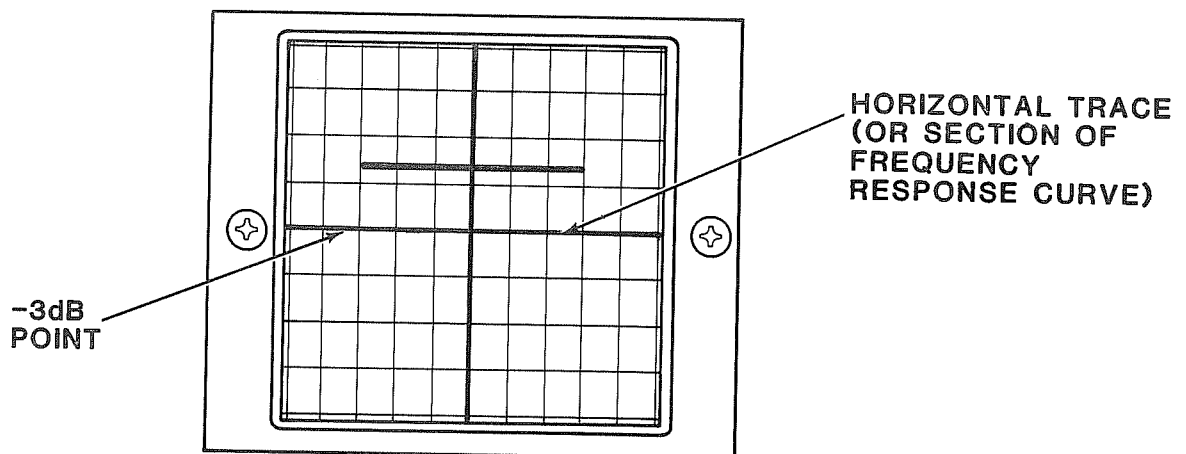

FIGURE 4-80 SECTION OF FREQUENCY RESPONSE CURVE DISPLAYED USING POSITIVE DETECTOR

STEP

PROCEDURE

3. (cont'd)

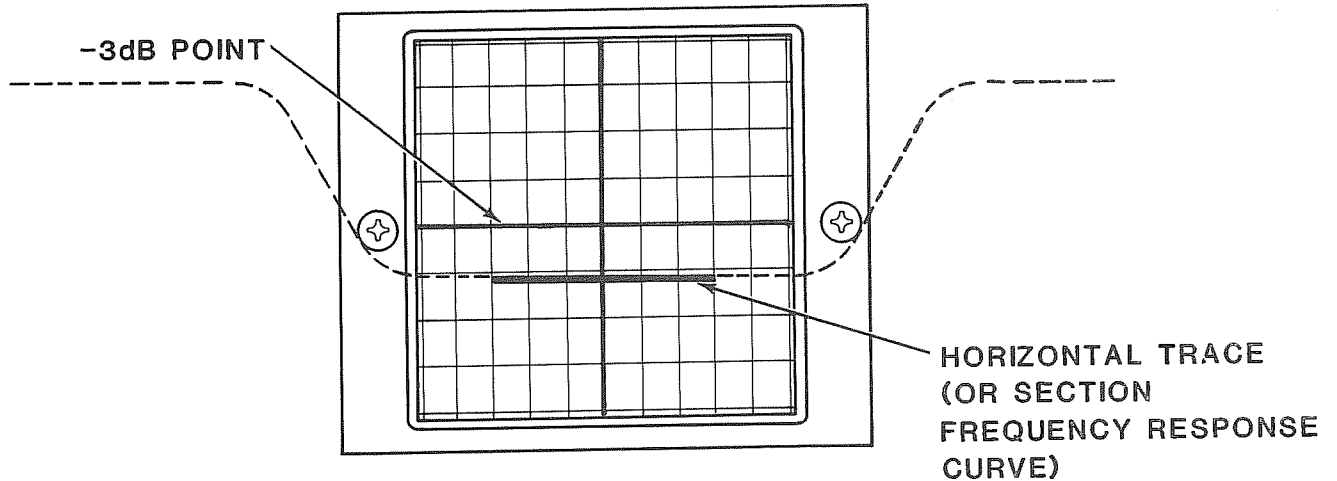

FIGURE 4-81 SECTION FREQUENCY RESPONSE CURVE DISPLAYED USING NEGATIVE DETECTOR

4. Increment FREQUENCY MHz Thumbwheels (32) to center high edge of frequency response curve at intersection of major vertical and horizontal axes.

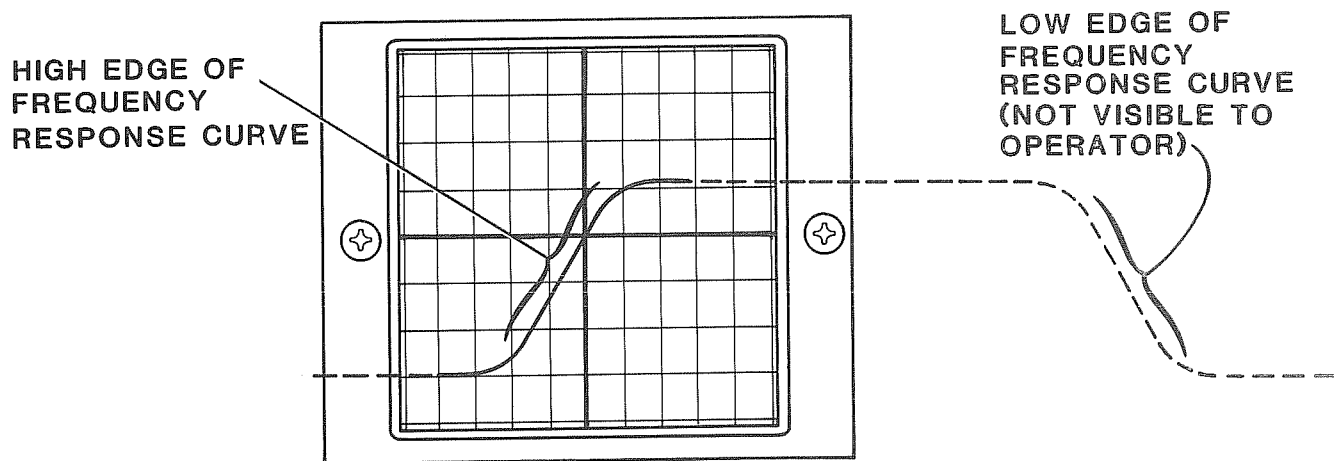

FIGURE 4-82 HIGH EDGE OF FREQUENCY RESPONSE CURVE CENTERED AT INTERSECTION OF MAJOR VERTICAL AND HORIZONTAL AXES (USING POSITIVE DETECTOR)

STEP

PROCEDURE

4. (cont'd)

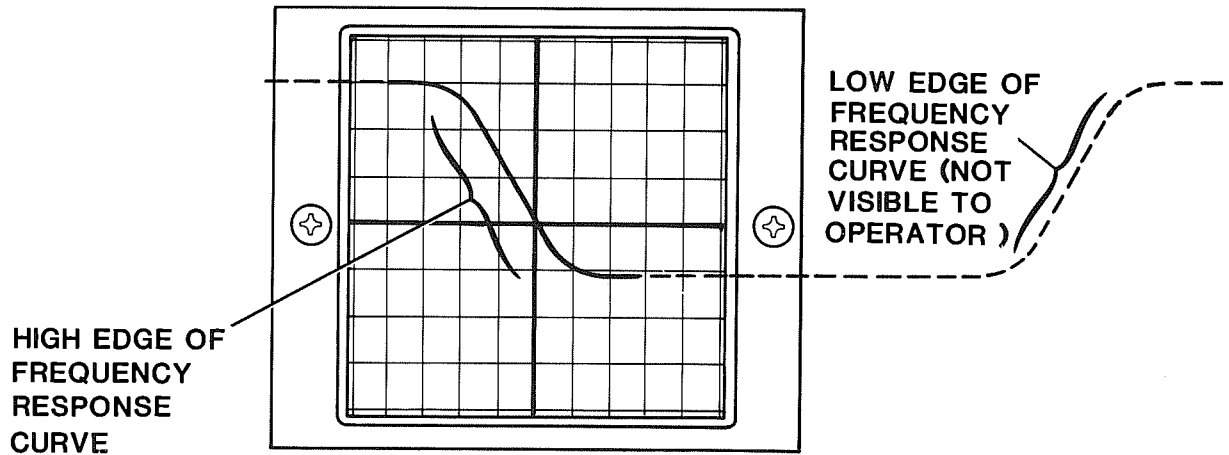

FIGURE 4-83 HIGH EDGE OF FREQUENCY RESPONSE CURVE CENTERED AT INTERSECTION OF MAJOR VERTICAL AND HORIZONTAL AXIS (USING NEGATIVE DETECTOR)

5. Record setting of FREQUENCY MHz Thumbwheels (32).
6. Decrement FREQUENCY MHz Thumbwheels (32) to center low edge of frequency response curve at intersection of major vertical and horizontal axes.

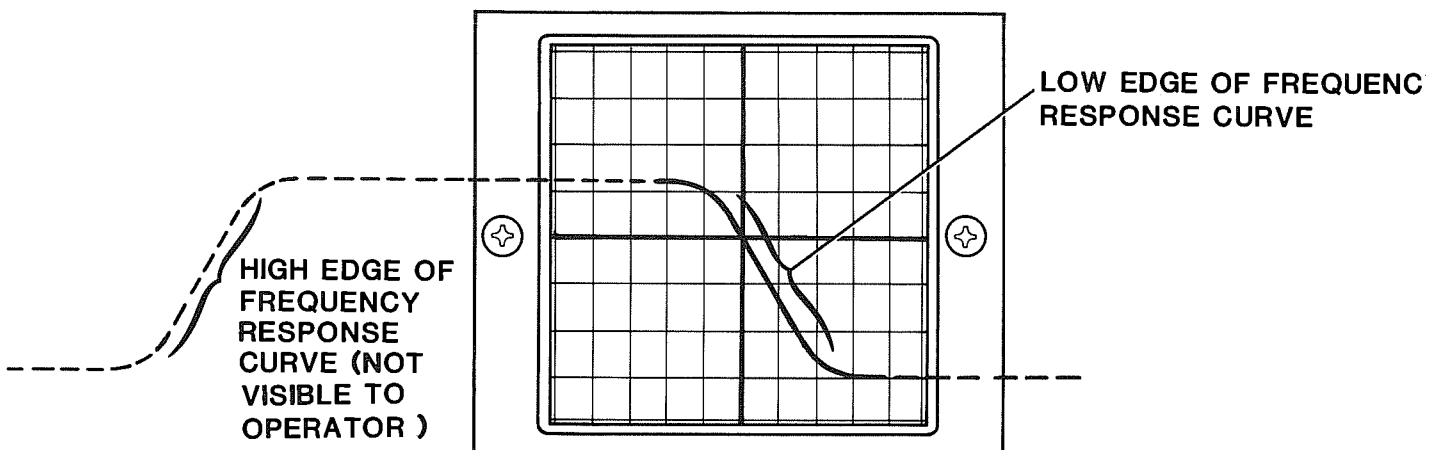

FIGURE 4-84 LOW EDGE OF FREQUENCY RESPONSE CURVE CENTERED AT INTERSECTION OF MAJOR VERTICAL AND HORIZONTAL AXIS (USING POSITIVE DETECTOR)

STEP

PROCEDURE

6. (cont'd)

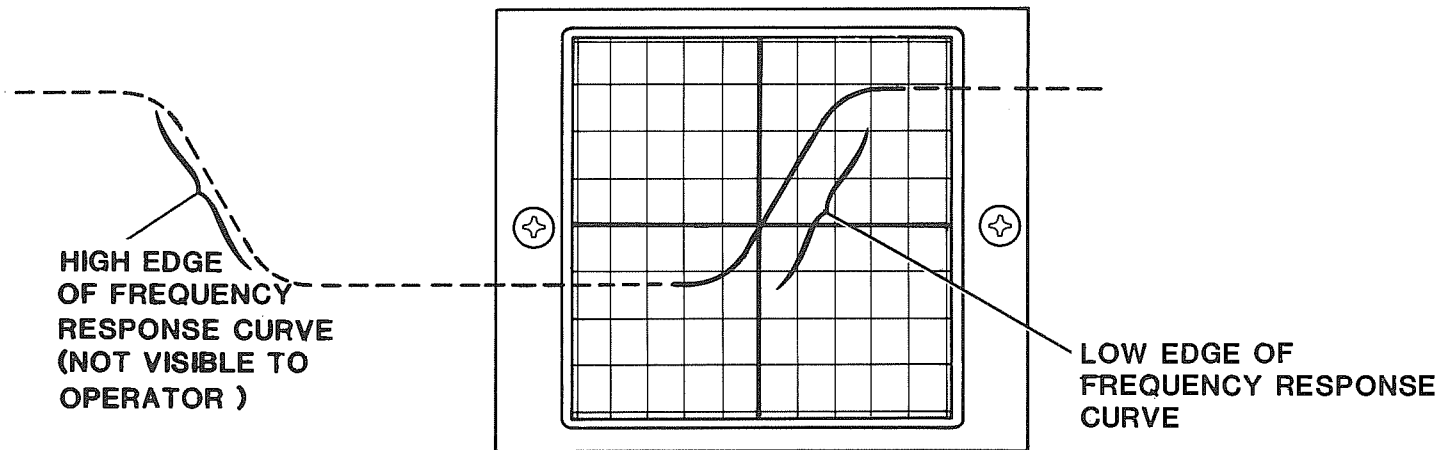

FIGURE 4-85 LOW EDGE OF FREQUENCY RESPONSE CURVE CENTERED AT INTERSECTION OF MAJOR VERTICAL AND HORIZONTAL AXIS (USING NEGATIVE DETECTOR)

7. Record present setting of FREQUENCY MHz Thumbwheels (32).
8. Subtract result obtained in Step 7 from result obtained in Step 5. Difference represents receiver bandpass.
9. To obtain bandpass center frequency, add result of Step 5 to result of Step 7 and divide total by two; quotient represents bandpass center frequency.





## 4-8-7

TEST PROCEDURE: **MEASURING SQUELCH THRESHOLD AND DIFFERENTIAL (FOR AM/FM RECEIVERS WITH FIXED SQUELCH CONTROL)**

TEST OBJECTIVE: Using FM/AM-1000S as a signal generator to determine power level required to activate/deactivate UUT squelch. The level at which squelch is deactivated is "squelch threshold"; the difference between squelch threshold and point at which squelch is activated is the "squelch differential."

SPECIAL ACCESSORY

EQUIPMENT REQ'D: 1 Coax cable with BNC male connector or one end and appropriate UUT connector on opposite end.

TEST SET-UP  
DIAGRAM:

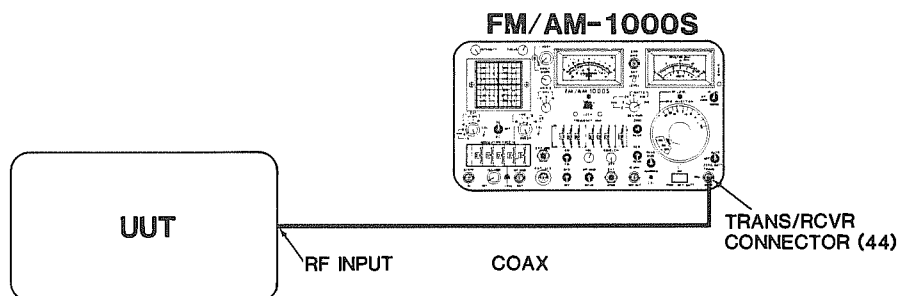

FIGURE 4-86 TEST SET-UP DIAGRAM FOR MEASURING SQUELCH THRESHOLD AND DIFFERENTIAL (FIXED SQUELCH)

- | STEP        | PROCEDURE   |
|-------------|---|
| 1.          | Perform test procedure 4-5-4 or 4-5-5, titled "GENERATING AM (or FM, whichever applicable) MODULATED SIGNALS", on pages 4-57 or 4-59. |
| <b>NOTE</b> |   |
|             | ● RF LEVEL/BFO INJECTION Dial (5) setting in above procedure should be .05 $\mu$ V.   |
| 2.          | Connect UUT to FM/AM-1000S using required accessory equipment as shown in test set-up diagram above.                                  |

## STEP

## PROCEDURE

3. Apply power to UUT.
4. Set UUT audio gain control to a midrange setting.
5. Rotate RF LEVEL/BFO INJECTION Dial (5) cw slowly, until UUT audio output just becomes audible. This point represents maximum squelch threshold in dBm.

**NOTE**

- If an audio tone is not heard before RF LEVEL/BFO INJECTION Dial (5) is fully cw, place HI LVL/ $\mu$ V X 100/NORM Switch (3) to " $\mu$ V x 100" position and repeat Step 5.

6. Record setting of RF LEVEL/BFO INJECTION Dial (5) on dBm scale.

**NOTE**

- If HI LVL/ $\mu$ V X 100/NORM Switch (3) is in " $\mu$ V x 100" position, mathematically add 40 dB to setting of RF LEVEL/BFO INJECTION Dial (5) on dBm scale to obtain true squelch threshold level.

7. Rotate RF LEVEL/BFO INJECTION Dial (5) ccw slowly until audio tone ceases. Record setting of RF LEVEL/BFO INJECTION Dial (5) on dBm scale.

**NOTE**

- If HI LVL/ $\mu$ V X 100/NORM Switch (3) is in " $\mu$ V x 100" position, mathematically add 40 dB to setting of RF LEVEL/BFO INJECTION Dial (5) on dBm scale to obtain true output level.

8. Subtract result of Step 5 from result of Step 7 to obtain squelch differential.

## EXAMPLE:

Result of Step 5: -42 dBm  
 Result of Step 7: -44 dBm

$$(-44 \text{ dBm}) - (-42 \text{ dBm}) =$$

$$-44 \text{ dBm} + 42 \text{ dBm} = 2 \text{ dB Squelch Differential}$$

## 4-8-8

TEST PROCEDURE: **MEASURING SQUELCH THRESHOLD AND DIFFERENTIAL (FOR AM/FM RECEIVERS WITH VARIABLE SQUELCH CONTROL)**

TEST OBJECTIVE: Using FM/AM-1000S as a signal generator to determine power level required to activate/deactivate UUT squelch. The level at which squelch is deactivated is "squelch threshold"; the difference between squelch threshold and point at which squelch is activated is the "squelch differential."

SPECIAL ACCESSORY  
EQUIPMENT REQ'D:

1 Coax cable with BNC male connector on one end and appropriate UUT connector on opposite end.

TEST SET-UP  
DIAGRAM:

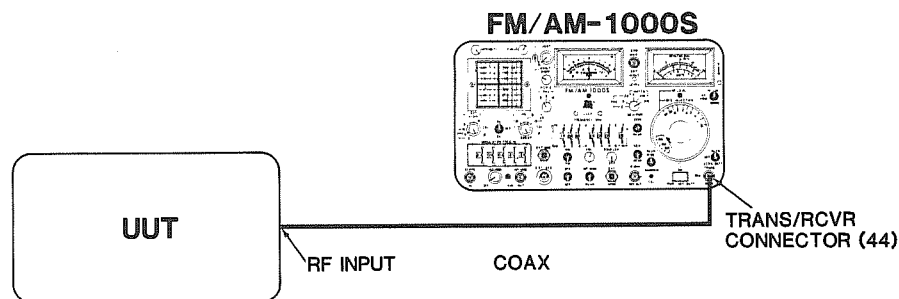

FIGURE 4-87 TEST SET-UP DIAGRAM FOR MEASURING SQUELCH THRESHOLD AND DIFFERENTIAL (VARIABLE SQUELCH)

- | STEP        | PROCEDURE   |
|-------------|---|
| 1.          | Perform test procedure 4-5-4 or 4-5-5, titled "GENERATING AM (or FM, whichever applicable) MODULATED SIGNALS", on pages 4-57 or 4-59. |
| <b>NOTE</b> |   |
|             | ● RF LEVEL/BFO INJECTION Dial (5) setting in above procedure should be .05 $\mu$ V.   |
| 2.          | Connect UUT to FM/AM-1000S using required accessory equipment as shown in test set-up diagram above.                                  |

## STEP

## PROCEDURE

3. Apply power to UUT.
4. Set UUT audio gain control to a midrange setting.
5. Set UUT squelch control fully ccw (or "OFF" in detent if applicable).
6. Rotate RF LEVEL/BFO INJECTION Dial (5) cw slowly to confirm a gradual increase in the audio output of UUT.

**NOTE**

- This action is required to confirm that UUT squelch is disabled; audio tone should not become audible abruptly.

7. Rotate RF LEVEL/BFO INJECTION Dial (5) fully ccw.
8. Rotate UUT squelch control fully cw (Full "ON").
9. Rotate RF LEVEL/BFO INJECTION Dial (5) cw slowly until UUT audio output just becomes audible. This point represents maximum squelch threshold in dBm.

**NOTE**

- If an audio tone is not heard before RF LEVEL/BFO INJECTION Dial (5) is fully cw, place HI LVL/ $\mu$ V X 100/NORM Switch (3) to " $\mu$ V x 100" position and repeat Step 9.

10. Record setting of RF LEVEL/BFO INJECTION Dial (5) on dBm scale.

**NOTE**

- If HI LVL/ $\mu$ V X 100/NORM Switch (3) is in " $\mu$ V x 100" position, mathematically add 40 dB to setting of RF LEVEL/BFO INJECTION Dial (5) on dBm scale to obtain true squelch threshold level.

11. Rotate RF LEVEL/BFO INJECTION Dial (5) ccw slowly until audio tone ceases. Record setting of RF LEVEL/BFO INJECTION Dial (5) on dBm scale.

**NOTE**

- If HI LVL/ $\mu$ V X 100/NORM Switch (3) is in " $\mu$ V x 100" position, mathematically add 40 dB to setting of RF LEVEL/BFO INJECTION Dial (5) on dBm scale to obtain true output level.

STEP

PROCEDURE

12. Subtract result of Step 9 from result of Step 11 to obtain squelch differential.

EXAMPLE:

Result of Step 9: -42 dBm

Result of Step 11: -44 dBm

$$\begin{aligned} (-44 \text{ dBm}) - (-42 \text{ dBm}) &= \\ -44 \text{ dBm} + 42 \text{ dBm} &= 2 \text{ dB Squelch Differential} \end{aligned}$$



4-8-9

TEST PROCEDURE: **MEASURING AGC ACTION (AM RCVR)**

TEST OBJECTIVE: Determining received signal strength at which receiver AGC circuit threshold is achieved.

**NOTE**

- This procedure is not valid for receivers with audio AGC in the output.

SPECIAL ACCESSORY  
EQUIPMENT REQ'D:

- 1 BNC "Tee" connector
- 1 "Dummy" load (to match impedance of UUT audio output)
- 2 Coax cables with BNC male connectors on one end and appropriate UUT connectors on opposite end.

TEST SET-UP  
DIAGRAM:

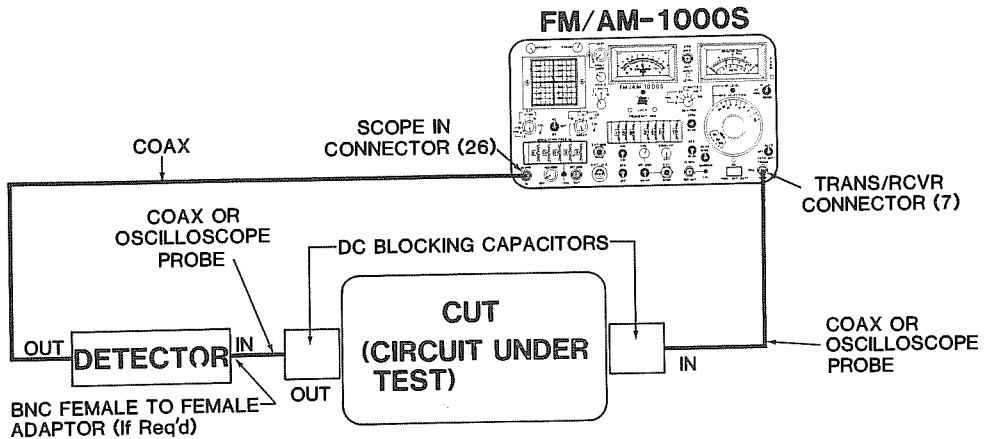

FIGURE 4-88 TEST SET-UP DIAGRAM FOR MEASURING AGC ACTION

STEP

PROCEDURE

1. Perform procedure 4-5-3, titled "GENERATING RF SIGNALS", on page 4-55.

**NOTE**

- RF LEVEL/BFO INJECTION Dial (5) setting in above procedure should be  $.05 \mu\text{V}$ .



- | STEP | PROCEDURE   |
|------|---|
| 2.   | Place AM/FM Switch (19) to "AM."  |
| 3.   | Set MODULATION FREQ Hz Thumbwheels (25) to 1000.0 Hz.   |
| 4.   | Rotate ANALY DISPR Control (39) fully ccw to detent position.   |
| 5.   | Rotate EXT V/DIV Control (31) to "1.5 kHz", "6 kHz" or "15 kHz" position.   |
| 6.   | Rotate EXT V/DIV Vernier Control (30) to "CAL" position.  |
| 7.   | Adjust INTENSITY Control (35) cw and FOCUS Control (37) appropriately for a sharp visible trace display.  |
| 8.   | Adjust VERT Control (38) and HORIZ Control (36) to obtain a centered trace, with lower edge of displayed carrier signal aligned with major horizontal axis. |

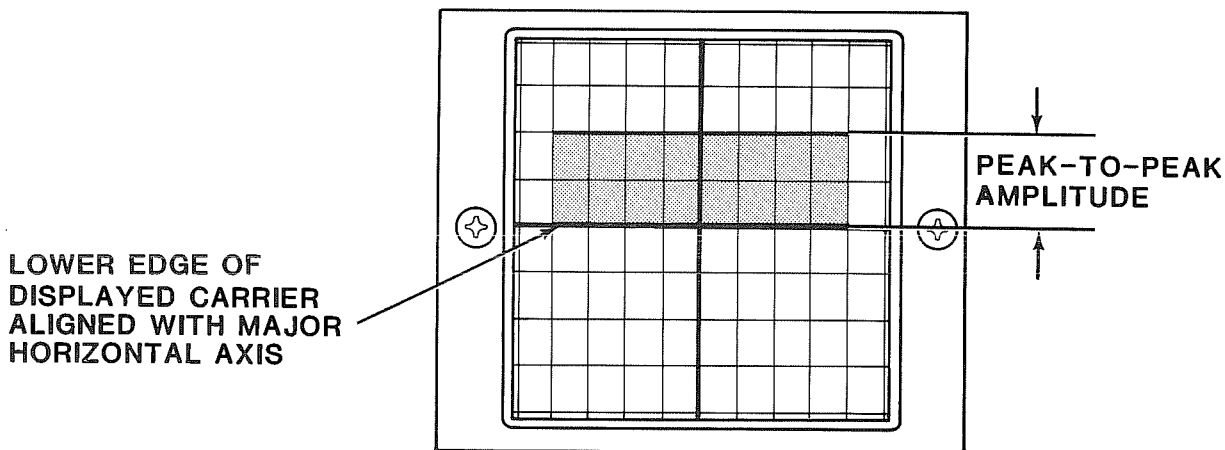

FIGURE 4-89 DISPLAYED CARRIER SIGNAL ALIGNED WITH MAJOR HORIZONTAL AXIS

9. Measure peak-to-peak amplitude (in graticule division) of displayed carrier. Record result.
10. Apply result obtained in Step 9 to following equation and record value of "x":
 
$$x = 0.3 (\text{Result of Step 9})$$
 Where x = number of graticule divisions (peak-to-peak) of modulated signal

## STEP

## PROCEDURE

11.
  - a. Adjust VERT Control (38) to align negative peak of one of the modulated signals with major horizontal axis.
  - b. Rotate INT MOD Control (23) to adjust peak-to-peak amplitude of same modulated signal (in graticule divisions) to value of "x" obtained in Step 10.

**NOTE**

- Steps 11a and 11b must be performed simultaneously, as both are interactive.

## EXAMPLES:

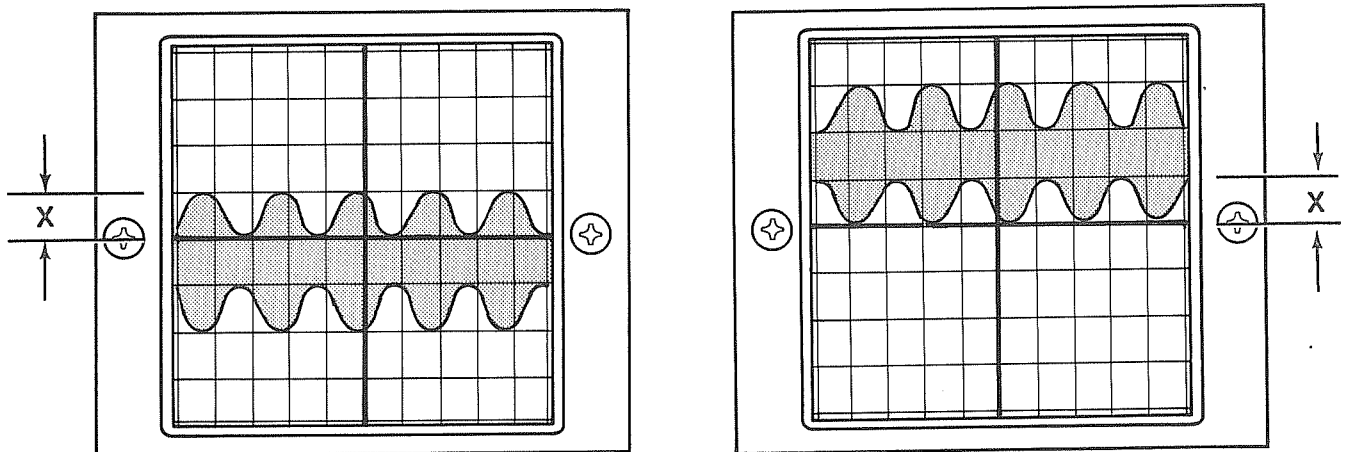

**FIGURE 4-90 ALIGNMENT OF UPPER AND LOWER MODULATION SIGNALS WITH MAJOR HORIZONTAL AXIS**

- c. The FM/AM-1000S signal generator is now calibrated to 30% modulation and is generating at selected frequency and output level.
12. Connect UUT to FM/AM-1000S to UUT and required test equipment as shown in test set-up diagram above.
13. Apply power to UUT.

STEP

PROCEDURE

14. Set UUT audio gain control to a midrange setting. Up to this point, FM/AM-1000S scope should display a modulated signal similar to that shown below.

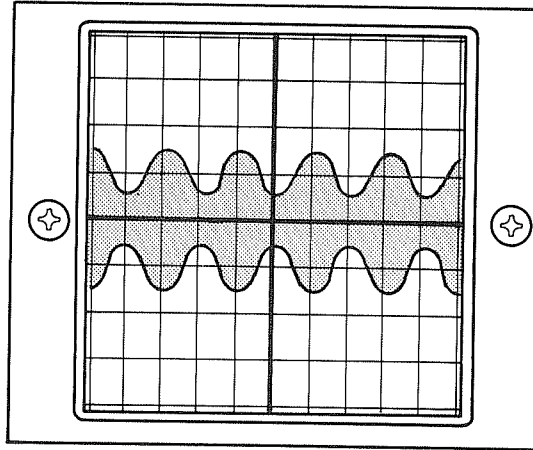

FIGURE 4-91 MODULATED SIGNAL DISPLAY

15. Rotate EXT V/DIV Control (31) to "10 volts/division" position. Scope may display a horizontal trace containing a small level of noise.

**NOTE**

- If audio output rating of UUT is low power, EXT V/DIV Control (31) may require positioning to "1 or .1 volts/division" setting.

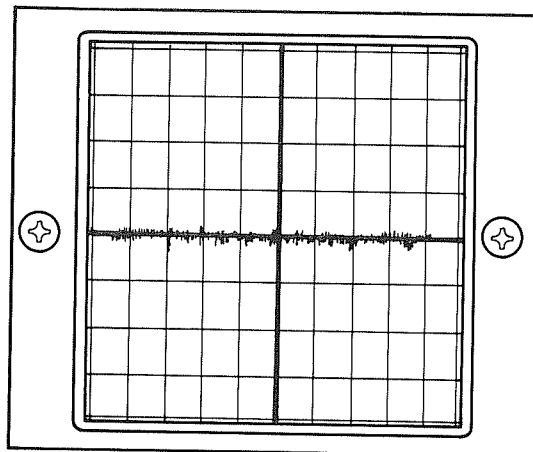

FIGURE 4-92 SCOPE TRACE EXHIBITING MINOR AMOUNT OF NOISE

STEP

PROCEDURE

16. Slowly rotate RF LEVEL/BFO INJECTION Dial (5) cw while observing scope display; the following progression will be evident with respect to horizontal trace on CRT:
- a. While rotating RF LEVEL/BFO INJECTION Dial (5) cw, noise on horizontal trace will continuously change in amplitude, ultimately developing into a sine wave.
  - b. The sine wave will increase in amplitude proportionately to the cw rotation of RF LEVEL/BFO INJECTION Dial (5).
  - c. During rotation of the RF LEVEL/BFO INJECTION Dial (5), a point will be reached where sine wave no longer increases in amplitude (or increases very little). Position RF LEVEL/BFO INJECTION Dial (5) to the point where this transition occurs.
  - d. Read setting of RF LEVEL/BFO INJECTION Dial (5) on dBm scale. This setting represents the "AGC threshold" of the UUT.

**NOTE**

- If the AGC threshold is not reached when RF LEVEL/BFO INJECTION Dial (5) is fully cw, place HI LVL/ $\mu$ V X 100/NORM Switch (3) to " $\mu$ V x 100" position and repeat Step 6. An additional 40 dB must now be mathematically added to reading obtained in Step 6d to obtain true AGC threshold.



## 4-8-10

TEST PROCEDURE: **MEASURING AM RECEIVER SENSITIVITY (AM RCVR)**

TEST OBJECTIVE: Determining carrier strength required to produce a 10 dB difference in receiver audio output between an unmodulated carrier and same carrier modulated at 30% with a 1 kHz tone.

SPECIAL ACCESSORY  
EQUIPMENT REQ'D: AC Voltmeter

TEST SET-UP  
DIAGRAM:

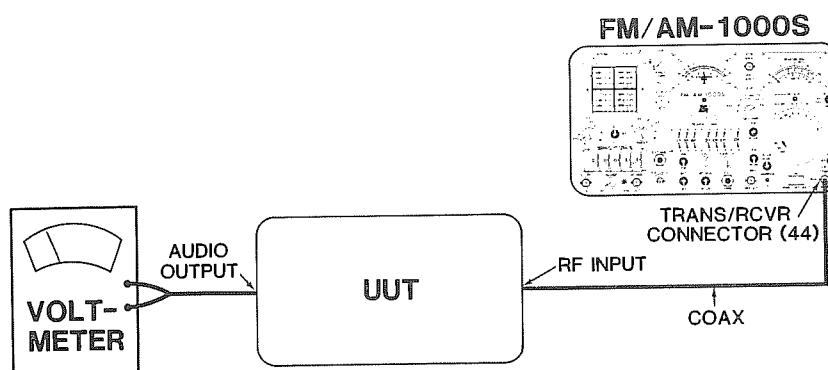

FIGURE 4-93 TEST SET-UP DIAGRAM FOR MEASURING AM SENSITIVITY

STEP	PROCEDURE
1.	Perform procedure 4-5-3, titled "GENERATING RF SIGNALS", on page 4-55.
2.	Place AM/FM Switch (19) to "AM."
3.	Set MODULATION FREQ Hz Thumbwheels (25) to 1000.0 Hz.
4.	Rotate ANALY DISPR Control (39) fully ccw to detent position.
5.	Rotate EXT V/DIV Control (31) to "1.5 kHz", "6 kHz" or "15 kHz" position.
6.	Rotate EXT V/DIV Vernier Control (30) to "CAL" position.
7.	Adjust INTENSITY Control (35) cw and FOCUS Control (37) appropriately for a sharp visible trace display.

## STEP

## PROCEDURE

8. Adjust VERT Control (38) and HORIZ Control (36) to obtain a centered trace, with lower edge of displayed carrier aligned with major horizontal axis.

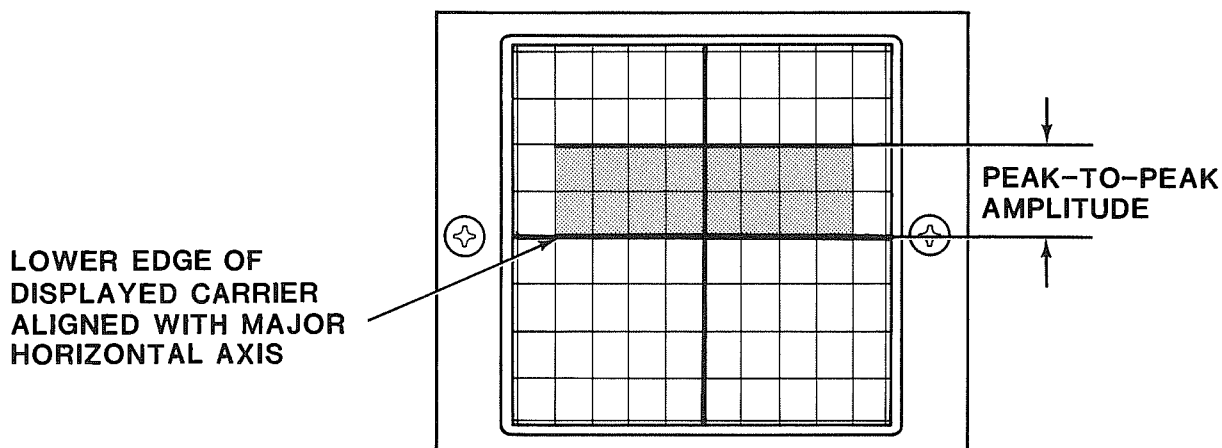

FIGURE 4-94 DISPLAYED CARRIER SIGNAL ALIGNED WITH MAJOR HORIZONTAL AXIS

9. Measure peak-to-peak amplitude (in graticule divisions) of displayed carrier. Record result.
10. Apply result obtained in Step 9 to following equation and record value of "x":
- $$x = 0.3 \text{ (Result of Step 9)}$$
- where x = number of graticule divisions (peak-to-peak) of modulated signal
11. a. Adjust VERT Control (38) to align negative peak of one of the modulated signals with major horizontal axis.
- b. Rotate INT MOD Control (23) to adjust peak-to-peak amplitude of same modulated signal (in graticule divisions) to value of "x" obtained in Step 10.

**NOTE**

- Steps 11a and 11b must be performed simultaneously, as both are interactive.

STEP

PROCEDURE

11. (cont'd)

EXAMPLES:

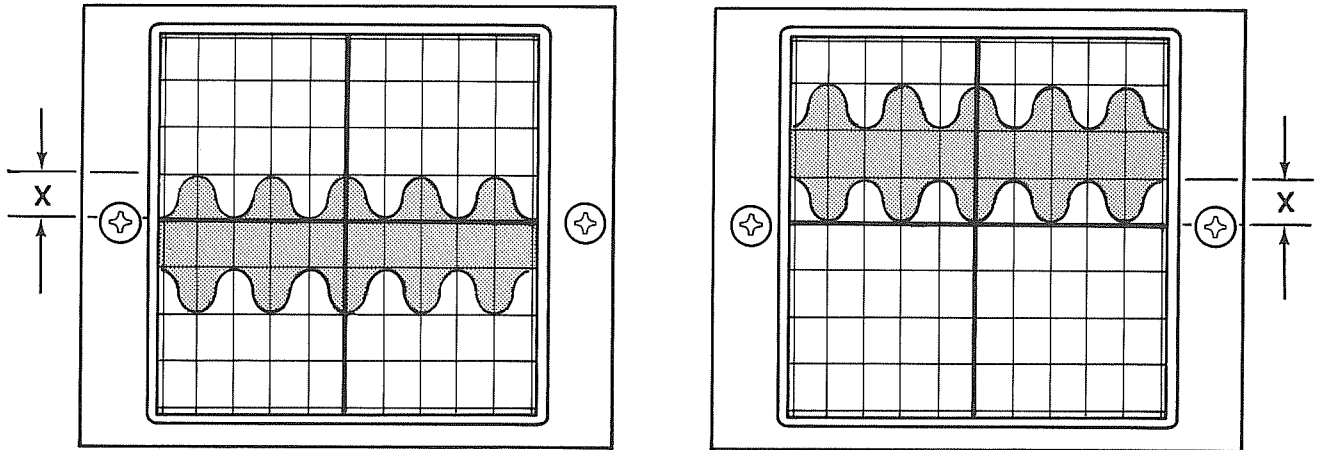

FIGURE 4-95 ALIGNMENT OF UPPER AND LOWER MODULATION SIGNALS WITH MAJOR HORIZONTAL AXIS

- c. The FM/AM-1000S signal generator is now calibrated to 30% modulation and is generating at selected frequency and output level.
12. Connect FM/AM-1000S to UUT and required accessory equipment as shown in Test Set-Up Diagram above.
13. Rotate RF LEVEL/BFO INJECTION Dial (5) cw until FM/AM-1000S is generating sufficient RF to quiet UUT.
14. Adjust UUT audio gain control to achieve maximum rated audio output power. Note value obtained on voltmeter.
15. Rotate INT MOD Control (23) fully ccw to detent (OFF) position (0% modulation).
16. Rotate RF LEVEL/BFO INJECTION Dial (5) appropriately until voltmeter displays a noise level 10 dB below level obtained in Step 14.
17. Rotate INT MOD Control (23) cw until modulated signal is again at 30% modulation. (Reference value of "x" obtained in Step 10.)



## STEP

## PROCEDURE

18. Check voltmeter reading; if voltmeter reading is equal to reading obtained in Step 14, setting of RF LEVEL/BFO INJECTION Dial (5) represents sensitivity of UUT (in  $\mu\text{V}$  or dBm). If voltmeter reading in this step does not equal reading obtained in Step 14, proceed with remaining steps below.
19. Record present voltmeter reading.
20. Rotate INT MOD Control (23) fully ccw to detent (OFF) position (0% modulation).
21. Rotate RF LEVEL/BFO INJECTION Dial (5) appropriately until voltmeter displays a noise level 10 dB below level obtained in Step 19.
22. Rotate IND MOD Control (23) cw until modulated signal is again at 30% modulation. (Reference value of "x" obtained in Step 10.)
23. Check voltmeter reading; if voltmeter reading is equal to reading obtained in Step 19, setting of RF LEVEL/BFO INJECTION Dial (5) represents sensitivity of UUT (in  $\mu\text{V}$  or dBm). If voltmeter reading does not equal result obtained in Step 19, repeat Steps 19 thru 23 until result of Step 21 is 10 dB below result of Step 23.

## 4-8-11

TEST PROCEDURE: **MEASURING FM RECEIVER 20 dB QUIETING (FM RCVR)**

TEST OBJECTIVE: To measure smallest discernable signal receiver under test is capable of receiving at a given noise level.

### SPECIAL ACCESSORY

EQUIPMENT REQ'D: 1 Coax cable with BNC male connector on one end and appropriate UUT connector on opposite end.

AC Voltmeter

### TEST SET-UP DIAGRAM:

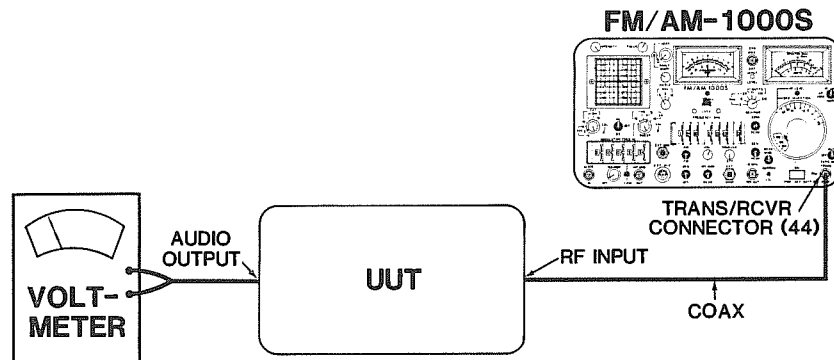

FIGURE 4-96 TEST SET-UP DIAGRAM FOR MEASURING FM RECEIVER 20 dB QUIETING

STEP	PROCEDURE
1.	Set FM/AM-1000S controls for RF generator operation as shown in Figure 4-25, page 4-53.
2.	Set FREQUENCY MHz Thumbwheels (32) to frequency of UUT.
3.	Connect BNC male connector on end of coax cable to TRANS/RCVR Connector (7) on FM/AM-1000S.

STEP PROCEDURE

3. (cont'd)

**CAUTION**

- DO NOT APPLY MORE THAN 20 WATTS OF CONTINUOUS INPUT TO THIS CONNECTOR. Maximum "ON" time for measurement of transmitter output using this connector is:

10 seconds at 100 W, 15% Duty Cycle  
20 seconds at 50 W, 30% Duty Cycle  
2 minutes at 30 W, 50% Duty Cycle

4. Connect opposite end of coax cable to RF input of UUT.
5. Connect AC voltmeter across audio output terminals of UUT.
6. Apply power to UUT.
7. Apply power to FM/AM-1000S.
8. Adjust UUT audio output to obtain convenient reference output level on voltmeter (preferably on an even division marking of voltmeter scale).
9. Rotate RF LEVEL/BFO INJECTION Dial (5) cw until voltmeter reading decreases to one-tenth (1/10) of original reference reading.

**NOTE**

- If it is not possible to obtain one-tenth (1/10) voltage reading of reference level, place HI LVL/ $\mu$ V X 100/NORM Switch (3) to " $\mu$ V x 100" position.

10. Read UUT sensitivity on "dBm" scale of RF LEVEL/BFO INJECTION Dial (5).

**NOTE**

- If HI LVL/ $\mu$ V X 100/NORM Switch (3) is in the " $\mu$ V x 100" position, mathematically add +40 dB to dBm reading of RF LEVEL/BFO INJECTION Dial (5) to obtain true sensitivity level.

EXAMPLE:

If result of Step 10 is -110 dBm, add +40 dB to this figure to obtain -60 dBm.

TEST PROCEDURE: **MEASURING 12 dB SINAD SENSITIVITY (FM RCVR)**

TEST OBJECTIVE: To measure the amount of input signal a receiver requires to produce an output 12 dB above noise and distortion output levels. The 12 dB SINAD (Signal plus Noise And Distortion) figure provides an indication of input signal level required for understandable voice reception.

In this test, a tone modulated FM signal is applied to the RF input of receiver under test (UUT). The receiver's total audio output level is measured and compared against receiver's noise/distortion level, while the RF input level is varied to obtain a 12 dB difference between the two levels.

SPECIAL ACCESSORY  
EQUIPMENT REQ'D:

Distortion Analyzer

Cables for connecting distortion analyzer to UUT.

- 1 Coax cable with BNC male connector on one end and appropriate UUT connector on opposite end.

TEST SET-UP  
DIAGRAM:

FIGURE 4-97 TEST SET-UP DIAGRAM FOR MEASURING 12dB SINAD SENSITIVITY

## STEP

## PROCEDURE

1. Set FM/AM-1000S controls for RF generator operation as shown in Figure 4-25, page 4-53.

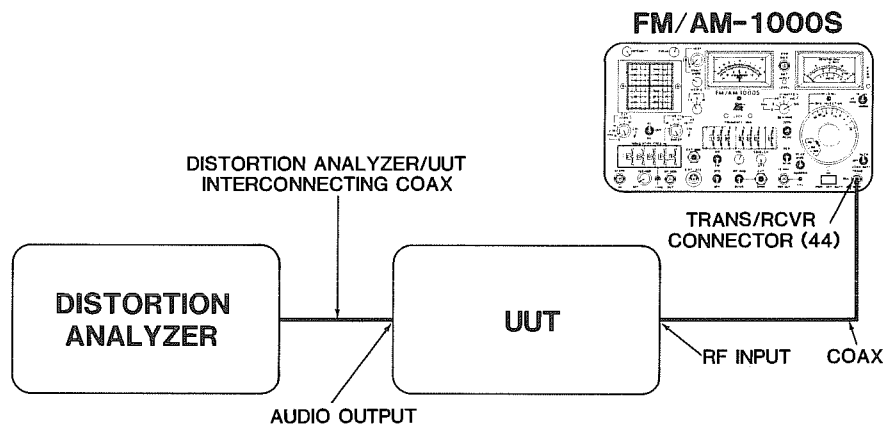
- | STEP | PROCEDURE  |
|------|--|
| 2.   | Make cable connections between FM/AM-1000S, UUT and distortion analyzer as shown in set-up diagram.            |
| 3.   | Apply power to distortion analyzer.  |
| 4.   | Apply power to UUT.  |
| 5.   | Apply power to FM/AM-1000S.  |
| 6.   | Set MODULATION FREQ Hz Thumbwheels (25) to 1000.0 Hz.  |
| 7.   | Set FREQUENCY MHz Thumbwheels (32) to receiving frequency of UUT.  |
| 8.   | Rotate INT MOD Control (23) cw so DEVIATION/WATTS Meter (1) reading is two-thirds (2/3) of UUT peak deviation. |
| 9.   | Rotate RF LEVEL/BFO INJECTION Dial (5) cw until FM/AM-1000S is generating sufficient RF to quiet UUT.          |

**NOTE**

- If unable to quiet receiver in above step, place HI LVL/ $\mu$ V X 100/NORM Switch (3) to " $\mu$ V x 100" position. Then rotate RF LEVEL/BFO INJECTION Dial (5) to a level sufficient to quiet receiver.
10. Adjust UUT audio output to maximum rated power level (refer to UUT specifications).
  11. Adjust distortion analyzer to display a ratio of signal to distortion levels.
  12. Rotate RF LEVEL/BFO INJECTION Dial (5) ccw until distortion analyzer displays 12 dB SINAD or 25% distortion.
    - a. Present setting of RF LEVEL/BFO INJECTION Dial (5) represents 12 dB SINAD sensitivity of UUT.

**NOTE**

- If HI LVL/ $\mu$ V x 100/NORM Switch is in the " $\mu$ V x 100" position, mathematically add +40 dB to dBm reading of RF/BFO INJECTION DIAL (5) to obtain true sensitivity level.

### 4-8-13

TEST PROCEDURE: **MEASURING MAXIMUM RECEIVABLE DEVIATION  
(FM RCVR)**

TEST OBJECTIVE: To determine maximum acceptable FM deviation of UUT.

SPECIAL ACCESSORY

EQUIPMENT REQ'D: See procedure titled "MEASURING 12 dB SINAD SENSITIVITY"

TEST SET-UP

DIAGRAM: See procedure titled "MEASURING 12 dB SINAD SENSITIVITY"

- | STEP | PROCEDURE   |
|------|---|
| 1.   | Perform procedure 4-8-12, titled "MEASURING 12 dB SINAD SENSITIVITY", on page 4-151.                            |
| 2.   | Rotate RF LEVEL/BFO INJECTION Dial (5) cw to increase dBm reading by 20 dB (or per UUT specifications).         |
| 3.   | Rotate INT MOD Control (23) cw until distortion analyzer displays a distortion level 12 dB below signal level.  |
| 4.   | Multiply reading of DEVIATION/WATTS Meter (1) by two. Result represents modulation acceptance bandwidth of UUT. |



## **4-9 GENERAL TRANSMITTER TESTS**



#### **4-9-1 GENERAL**

This section contains an assortment of the more common tests to be used in evaluating AM/FM transmitter performance using the FM/AM-1000S. The tests included were selected on the basis of appropriateness, wide ranging applicability and minimal support equipment required to complete the tests.

This test procedures contained in this section are:

- 4-9-2 MEASURING TRANSMITTER CARRIER POWER
- 4-9-3 MEASURING TRANSMITTER FREQUENCY
- 4-9-4 MEASURING AM MODULATION OF A TRANSMITTER
- 4-9-5 MEASURING TRANSMITTER DEVIATION (Below  
±20 kHz)

## 4-9-2

TEST PROCEDURE: **GENERAL TRANSMITTER TEST MEASURING TRANSMITTER CARRIER POWER**

TEST OBJECTIVE: N/A

SPECIAL ACCESSORY

EQUIPMENT REQ'D: 1 Coax cable with BNC male connector on one end and appropriate UUT connector on opposite end.

TEST SET-UP  
DIAGRAM:

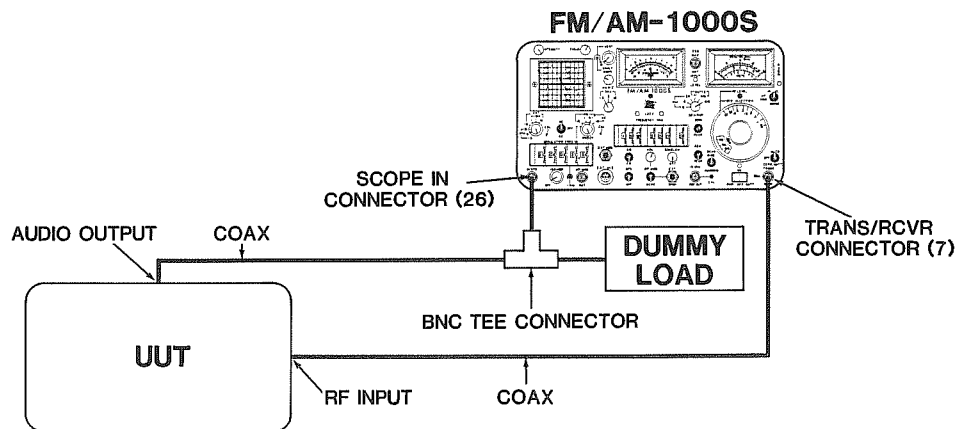

FIGURE 4-98 TEST SET-UP DIAGRAM FOR MEASURING TRANSMITTER CARRIER POWER

- | STEP | PROCEDURE   |
|------|---|
| 1.   | Set FM/AM-1000S controls for receiver operation (AM or FM) as shown in Figure 4-28, page 4-63.                            |
| 2.   | Apply power to FM/AM-1000S.   |
| 3.   | Apply power to UUT.   |
| 4.   | Connect coax cable between UUT RF output and FM/AM-1000S TRANS/RCVR Connector (7), as shown in test set-up diagram above. |
| 5.   | Rotate DEV/PWR Control (47) to "WATTS x 10" position.   |

STEP

PROCEDURE

6. Key up UUT. Read UUT power output on red scale of DEVIATION/WATTS Meter (1).

**NOTE**

- If DEVIATION/WATTS Meter (1) needle deflection is less than 10 Watts when UUT is keyed, rotate DEV/PWR Control (46) to "WATTS x 1" position.
- UUT power output can also be viewed on spectrum analyzer dB scale, using following approximate equivalencies (FREQUENCY MHz Thumbwheels must be set to frequency of UUT and ANALY DISPR Control must be out of detent position):
  - 30 dB marking on spectrum analyzer = 100 Watts
  - 40 dB marking on spectrum analyzer = 10 Watts
  - 50 dB marking on spectrum analyzer = 1 Watt
  - 60 db marking on spectrum analyzer = .1 Watt

### 4-9-3

TEST PROCEDURE: **MEASURING TRANSMITTER FREQUENCY**

TEST OBJECTIVE: N/A

SPECIAL ACCESSORY

EQUIPMENT REQ'D: Same as for procedure titled "MEASURING TRANSMITTER CARRIER POWER"

TEST SET-UP

DIAGRAM: Same as for procedure titled "MEASURING TRANSMITTER CARRIER POWER"

- | STEP | PROCEDURE   |
|------|---|
| 1.   | Set FM/AM-1000S controls for receiver operation (AM or FM) as shown Figure 4-28, page 4-63.                           |
| 2.   | Set FM/AM-1000S controls for spectrum analyzer operation as shown in Figure 4-16, page 4-33.                          |
| 3.   | Connect coax cable between UUT output and FM/AM-1000S TRANS/RCVR Connector (7) as shown in test set-up diagram above. |
| 4.   | Apply power to FM/AM-1000S.   |
| 5.   | Apply power to UUT.   |
| 6.   | Adjust INTENSITY Control (35) cw and FOCUS Control (37) appropriately to obtain a sharp visible trace display.        |

#### **NOTE**

- Warm-up time of CRT is approximately 30 seconds from a "cold" start-up; trace display will not become visible until CRT achieves warm-up.
- |     |  |
|-----|--|
| 7.  | Set FREQUENCY MHz Thumbwheels (32) to within $\pm 5$ MHz of UUT frequency.   |
| 8.  | Key up UUT while observing spectrum analyzer. Locate UUT spectrum.   |
| 9.  | Increment or decrement FREQUENCY MHz Thumbwheels (32) while continuously keying UUT, until spectrum of UUT is aligned with major vertical axis on CRT. |
| 10. | Rotate ANALY DISPR Control (39) fully ccw short of detent position.  |
| 11. | Repeat Step 9.   |

STEP

PROCEDURE

12. Rotate 1.5/5/15 kHz Control (33) to "5 kHz" position.
13. Increment or decrement FREQUENCY MHz Thumbwheels (32) while continuously keying UUT, until FREQ ERROR Meter (41) reads zero.
14. Rotate 1.5/5/15 kHz Control (33) to "1.5 kHz" position.
15. Repeat Step 13.
16. Add or subtract residual FREQ ERROR Meter (41) reading (less than 100 Hz) to or from setting of FREQUENCY MHz Thumbwheels (32). Result represents transmitting frequency.

TEST PROCEDURE: **MEASURING AM MODULATION OF A TRANSMITTER**

TEST OBJECTIVE: N/A

SPECIAL ACCESSORY  
EQUIPMENT REQ'D:

- 1 BNC "Tee" connector
- 2 Coax cables with BNC male connectors on one end and appropriate UUT connectors on opposite end.
- 1 Short coax cable with BNC male connector on each end.
- 1 DC blocking capacitor (required only if DC components are present)

TEST SET-UP  
DIAGRAM:

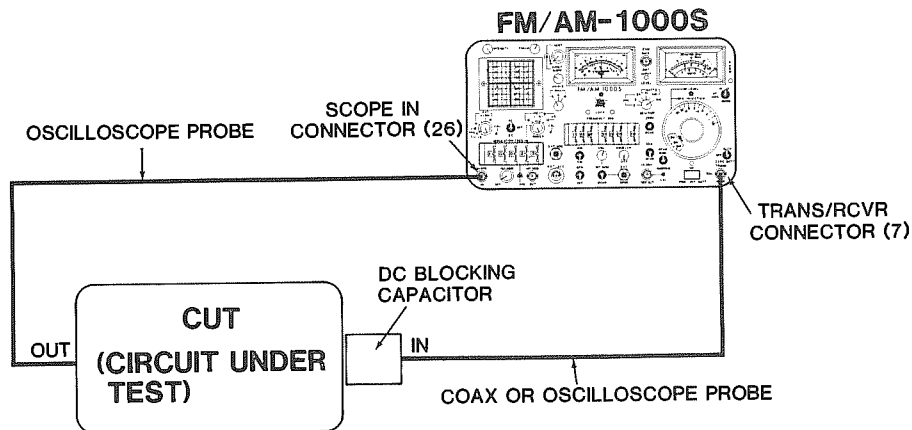

FIGURE 4-99 TEST SET-UP DIAGRAM FOR MEASURING AM MODULATION OF A TRANSMITTER

- | STEP | PROCEDURE  |
|------|--|
| 1.   | Perform Steps 1 through 12 of procedure 4-4-3, titled "GENERATING AUDIO TONES OF KNOWN AMPLITUDE", on page 4-47. Frequency of audio tone to be generated is 1 kHz. |

**NOTE**

- Amplitude of injected 1 kHz audio tone must be within limits of UUT input specifications.
- Tone injection point on UUT is "Audio Input" or "Microphone Jack."

## STEP

## PROCEDURE

2. Set FM/AM-1000S controls for AM receiver operation as shown in Figure 4-28, page 4-63.

**NOTE**

- DO NOT ALTER SETTING OF INT MOD CONTROL (23).

3. Set FM/AM-1000S controls for oscilloscope operation as shown in Figure 4-1, page 4-5.
4. Set EXT V/DIV Control (31) to "1.5 kHz", "6 kHz" or "15 kHz" position.
5. Adjust INTENSITY Control (35) cw and FOCUS Control (37) appropriately to obtain a sharp visible trace display.

**NOTE**

- Warm-up time of CRT is approximately 30 seconds from a "cold" start-up; trace display will not become visible until CRT achieves warm-up.
6. Oscilloscope should now display a noise level of approximately 2.5 to 3 graticule divisions in amplitude.

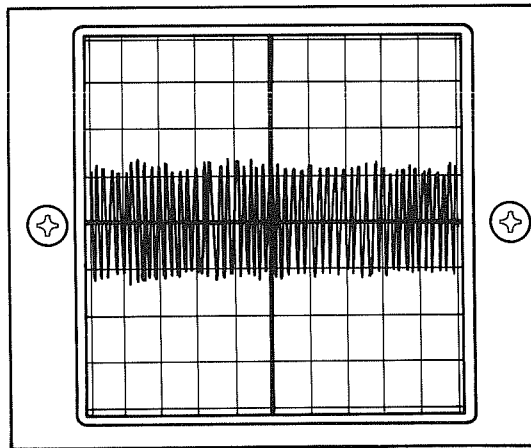

**FIGURE 4-100 NOISE LEVEL DISPLAY OF APPROX. 2.5 GRATICULE DIVISIONS (PEAK -TO-PEAK )**

7. Adjust VERT Control (38) and HORIZ Control (36) to center scope display over major horizontal axis of CRT.
8. Apply power to UUT.

## STEP

## PROCEDURE

9. Key up UUT while observing oscilloscope display. While keying UUT, rotate VERT Control (38) so negative peaks of modulation envelope rest on any horizontal axis.

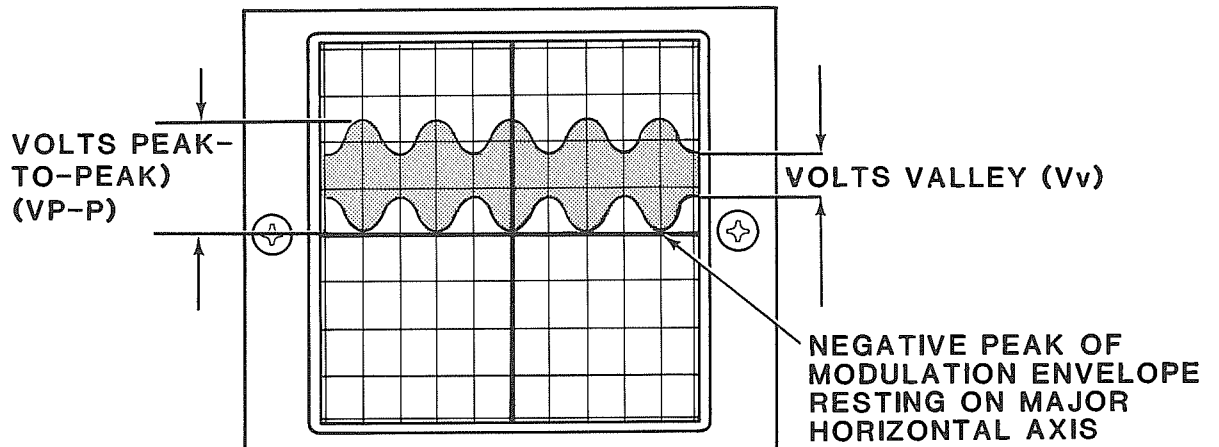

**FIGURE 4-101 NEGATIVE PEAKS OF MODULATION ENVELOPE RESTING ON MAJOR HORIZONTAL AXIS**

10. Measure Volts peak-to-peak ( $V_{p-p}$ ) (in major graticule divisions) of displayed modulation envelope. Record result.
11. Measure distance Volts valley ( $V_v$ ) (in major graticule divisions) of displayed modulation envelope. Record result.
12. To determine "percent modulation", apply result of Steps 10 and 11 to following equation:

$$\frac{V_{p-p} - V_v}{V_{p-p} + V_v} \times 100 = \% \text{ Modulation}$$





## 4-9-5

TEST PROCEDURE: **MEASURING TRANSMITTER DEVIATION (BELOW 20 kHz)**

TEST OBJECTIVE: N/A

### SPECIAL ACCESSORY

#### EQUIPMENT REQ'D:

- 1 BNC "Tee" Connector
- 2 Coax cables with BNC male connectors on one end and appropriate UUT connectors on opposite end
- 1 Short coax cable with BNC male connector on each end
- 1 DC blocking capacitor

### TEST SET-UP DIAGRAM:

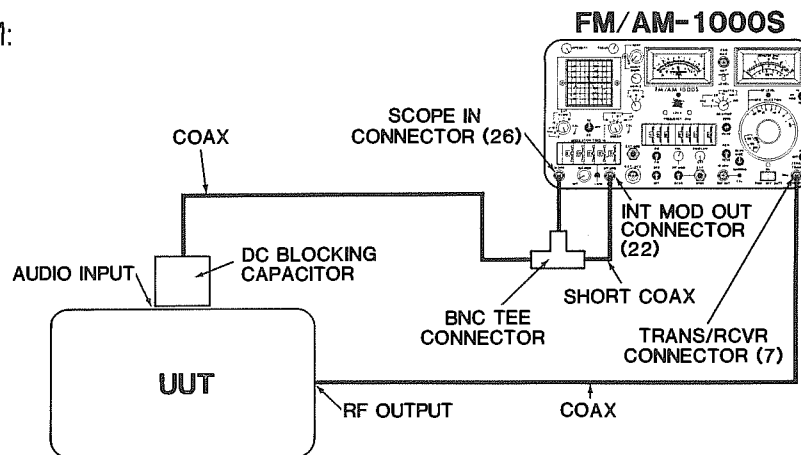

FIGURE 4-102 TEST SET-UP DIAGRAM FOR MEASURING TRANSMITTER DEVIATION

### STEP

### PROCEDURE

1. Perform procedure 4-4-3, titled "GENERATING AUDIO TONES OF KNOWN AMPLITUDE", on page 4-47. Frequency of audio tone to be generated is 1 kHz; set MODULATION FREQ Hz Thumbwheels (25) 1000.0 Hz.

### NOTE

- Amplitude of injected 1 kHz audio tone must be within limits of UUT input specifications.
  - Tone injection point on UUT is "Audio Input" or "Microphone Jack."
2. Set FM/AM-1000S controls for FM receiver operation as shown in Figure 4-28, page 4-63.

STEP

PROCEDURE

3. Place DEV/PWR Control (47) to "20 kHz" position.
4. Key up UUT and proceed to Step 5.
5. Observe reading of DEVIATION/WATTS Meter (1):
  - a. If reading on uppermost scale of meter is less than 6 kHz, rotate DEV/PWR Control (47) to "6 kHz" position and proceed to Step 5b. If reading is above 6 kHz, proceed directly to Step 5c.
  - b. If reading on middle scale is less than 2 kHz, rotate DEV/PWR Control (47) to "2 kHz" position and proceed to Step 5c. If reading is above 2 kHz, proceed directly to Step 5c.
  - c. Record reading of meter. Result represents peak FM deviation of UUT.

# SECTION 5- RECEIVER ALIGNMENT AND TROUBLESHOOTING

## 5-1 GENERAL

This section contains instructions for aligning and troubleshooting most typical AM/FM receivers, using the FM/AM-1000S. For ease of understanding the alignment/troubleshooting thought process, most of the information contained in this section is presented in the form of logical flowcharts. These flowcharts will enable operator to evaluate overall UUT performance and will provide a systematic means of localizing/correcting common receiver problems

### NOTE

- The receiver alignment/troubleshooting procedures contained in this manual are provided primarily for the benefit of the novice technician.

The information contained in this section is divided into the following subsections:

Section	Title
5-2	ROUTINE MAINTENANCE CHECKLIST
5-3	AM/FM RECEIVER ALIGNMENT FLOWCHART
5-4	AM/FM RECEIVER TROUBLESHOOTING FLOWCHARTS
5-4-1	Power Supply Troubleshooting Flowchart
5-4-2	Oscillator Troubleshooting Flowchart
5-4-3	RF Amplifier Troubleshooting Flowchart
5-4-4	IF Amplifier Troubleshooting Flowchart
5-4-5	Receiver Section Troubleshooting Flowchart
5-4-6	Squelch Troubleshooting Flowchart
5-4-7	AGC Troubleshooting Flowchart
5-4-8	AM Audio Troubleshooting Flowchart
5-4-9	Sensitivity Troubleshooting Flowchart
5-4-10	Squelch Enable Troubleshooting Flowchart
5-4-11	FM Audio Troubleshooting Flowchart
5-4-12	Maximum Receivable Deviation Troubleshooting Flowchart

### 5-1-1 PRELIMINARY CONSIDERATIONS

1. For maximum benefit of all the alignment/troubleshooting procedures contained herein, it is strongly recommended that operator be familiar with the circuit under test so some idea is perceived as to voltage, frequency and waveform to be expected at each test point. This knowledge will aid operator in performing the alignment/troubleshooting procedures in a logical efficient manner, with a minimum of blind searching.
2. The flowcharts contained in this section are primarily intended to cover those receiver problems which occur continuously, as opposed to those occurring intermittently or at random intervals. Intermittent problems are more difficult to troubleshoot because of the difficulty in making the malfunction occur on cue. With this type of problem, operator should strive to:

### **5-1-1 PRELIMINARY CONSIDERATIONS (CONT'D)**

- a. Determine conditions under which problem is most likely to occur.
- b. Simulate those conditions so the problem can be corrected.

Examples of intermittent type problems are:

- (1) Malfunctions related to temperature (e.g. UUT operates satisfactorily for a period when first energized; when UUT achieves warm-up, malfunction occurs).
  - (2) Malfunctions related to vibration (e.g. UUT operates satisfactorily in a test bench environment, but not under mobile conditions).
  - (3) Malfunctions related to control position, mode or range. (e.g. malfunction occurs only when a given UUT control is in a certain position).
3. As a prerequisite to performing the procedures contained in this section, it is recommended that operator obtain as much technical data as possible on UUT. (Data should include block diagrams, schematics, specifications and if available, maintenance procedures recommended by UUT manufacturer.) This information will be useful in providing location of test points, correct test point values, correct input/output specifications as well as details relative to overall UUT design.

### **5-1-2 ALIGNMENT/TROUBLESHOOTING SAFETY PRECAUTIONS**

In addition to the general safety precautions listed under Section 2-1-1 of this manual, the operator must observe the following additional alignment/troubleshooting precautions:

1. When working with "live" circuits of high potential, keep one hand in pocket or behind back to avoid serious shock hazard.
2. Remove all jewelry or other cosmetic apparel before performing any test procedures involving "live" circuits.
3. Use only insulated troubleshooting tools when working with "live" circuits.
4. For added insulation, place rubber bench mat underneath all powered bench equipment, as well as a rubber floor mat underneath operator chair.
5. Heed all WARNINGS and CAUTIONS concerning maximum voltage and power inputs.

### 5-1-2 ALIGNMENT/TROUBLESHOOTING SAFETY PRECAUTIONS (CONT'D)

6. Avoid using oscilloscope/spectrum analyzer in direct sunlight as scope trace is difficult to see under these conditions.
7. Do not allow scope trace to become concentrated on CRT as a stationary spot, as CRT screen may be burned permanently. Reduce trace intensity if trace must remain stationary.
8. Protect FM/AM-1000S from vibration or mechanical shock. The CRT of the FM/AM-1000S is highly evacuated and if broken, will implode causing possible serious injury from fragmented glass.

### 5-1-3 HOW TO USE ALIGNMENT/TROUBLESHOOTING FLOWCHARTS

To begin the alignment/troubleshooting process, perform procedures below in sequence given:

1. ROUTINE MAINTENANCE CHECKLIST (Section 5-2)  
Requires visual inspection of UUT exterior and interior components.
2. RECEIVER ALIGNMENT FLOWCHART (Section 5-3)  
The alignment chart serves as initial starting point for determining overall UUT performance as follows:
  - a. For instructions on how to perform certain alignment procedures using FM/AM-1000S, operator will be referred to appropriate test procedure in "SECTION 4, OPERATION" of this manual. On the alignment flowchart, those references will appear within the following symbol:

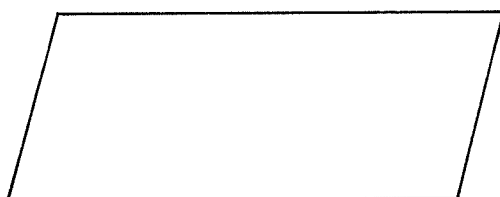

FIGURE 5-1 FLOWCHART SYMBOL REFERENCING AN OPERATING TEST PROCEDURE CONTAINED IN SECTION 4

- b. If during the course of alignment, certain UUT performance parameters do not meet expected norm, operator will be referred to troubleshooting flowcharts in "SECTION 5-4" of this manual. These flowcharts will provide general recommendations for troubleshooting various stages of the UUT.

### 5-1-3 HOW TO USE ALIGNMENT/TROUBLESHOOTING FLOWCHARTS (CONT'D)

b. (cont'd)

On the alignment chart, references to a given troubleshooting flowchart will appear within following symbol:

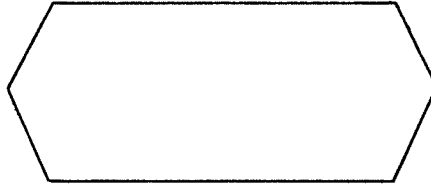

FIGURE 5-2 FLOWCHART SYMBOL REFERENCING A TROUBLESHOOTING FLOWCHART CONTAINED IN SECTION 5

c. Once a UUT performance problem has been located and corrected, operator is directed to a "RETURN" block (as shown below) at conclusion of troubleshooting flowchart. This block requires operator to return to "START" block of "RECEIVER ALIGNMENT FLOWCHART" and repeat all steps of the alignment procedure.

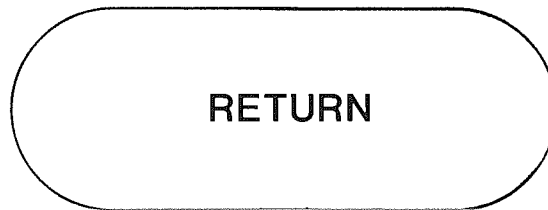

FIGURE 5-3 FLOWCHART SYMBOL DIRECTING OPERATOR TO RETURN TO "START" OF "RECEIVER ALIGNMENT FLOWCHART"

## 5-2 ROUTINE MAINTENANCE CHECKLIST

This section provides a checklist useful in determining the physical condition of a UUT through visual inspection. Defects resulting from wear, physical damage or deterioration can be detected using this checklist.

### **WARNING**

- Power to UUT must be disconnected while completing entire checklist.
1. INSPECT UUT EXTERIOR FOR VISIBLE DAMAGE (Repair or replace damaged components as required):
    - a. Check for scratches, dents, punctures, badly worn areas, broken covers or other evidence reflective of possible internal damage.
    - b. Check for burned or scorched paint on UUT covers indicating possible UUT overheating.
    - c. Check for clogged cooling vents or air filters.
    - d. Check for evidence of corrosion.
  2. INSPECT UUT CONTROLS AND INDICATORS FOR DEFECTIVE OR DAMAGED HARDWARE (Repair or replace damaged components as required):
    - a. Check for loose control knobs.
    - b. Check for cracked or broken bezels, lamps etc.
    - c. Check for burned out indicator lamps.
    - d. Check for defective control knob or switch detents.
  3. INSPECT UUT CONNECTORS FOR VISIBLE DAMAGE (Repair or replace damaged components as required):
    - a. Check for corroded contacts, pins etc.
    - b. Check for loose, bent or broken pins.
    - c. Check for damaged connector housings or insulation.
    - d. Check for improperly soldered or broken connections.



## 5-2 ROUTINE MAINTENANCE CHECKLIST (CONT'D)

### 4. WITH UUT COVERS OFF, CLEAN INNER COMPONENTS OF UUT:

Recommended cleaning supplies: Denatured alcohol, soft bristle brush, lint-free cloth and hand controlled dry air jet (30 psi maximum pressure).

- a. Remove dust and dirt from all electrical components. (Dust all components with bristle brush or dry air jet and where applicable, clean with lint-free cloth moistened with denatured alcohol.)

#### **CAUTION**

- Use air jet cautiously to avoid damaging fragile components.
- b. Clean all accessible switch and relay contacts.
  - c. Use denatured alcohol to clean any corroded areas.
  - d. Inspect for any leaky components. Replace as necessary.

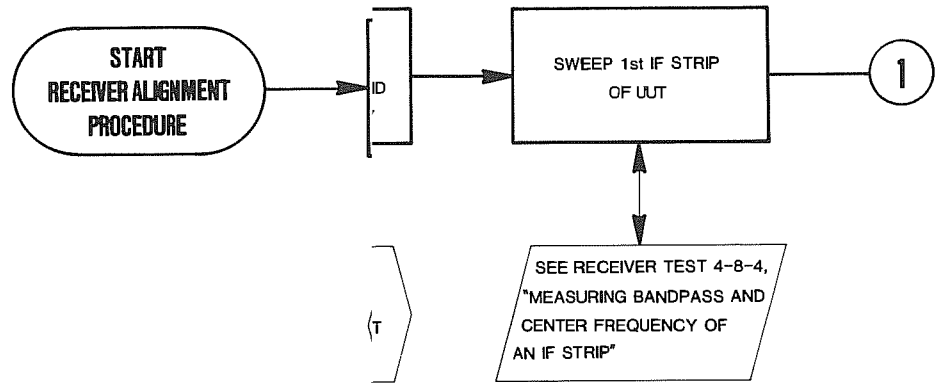

**5-3  
RECEIVER  
ALIGNMENT  
FLOWCHART**

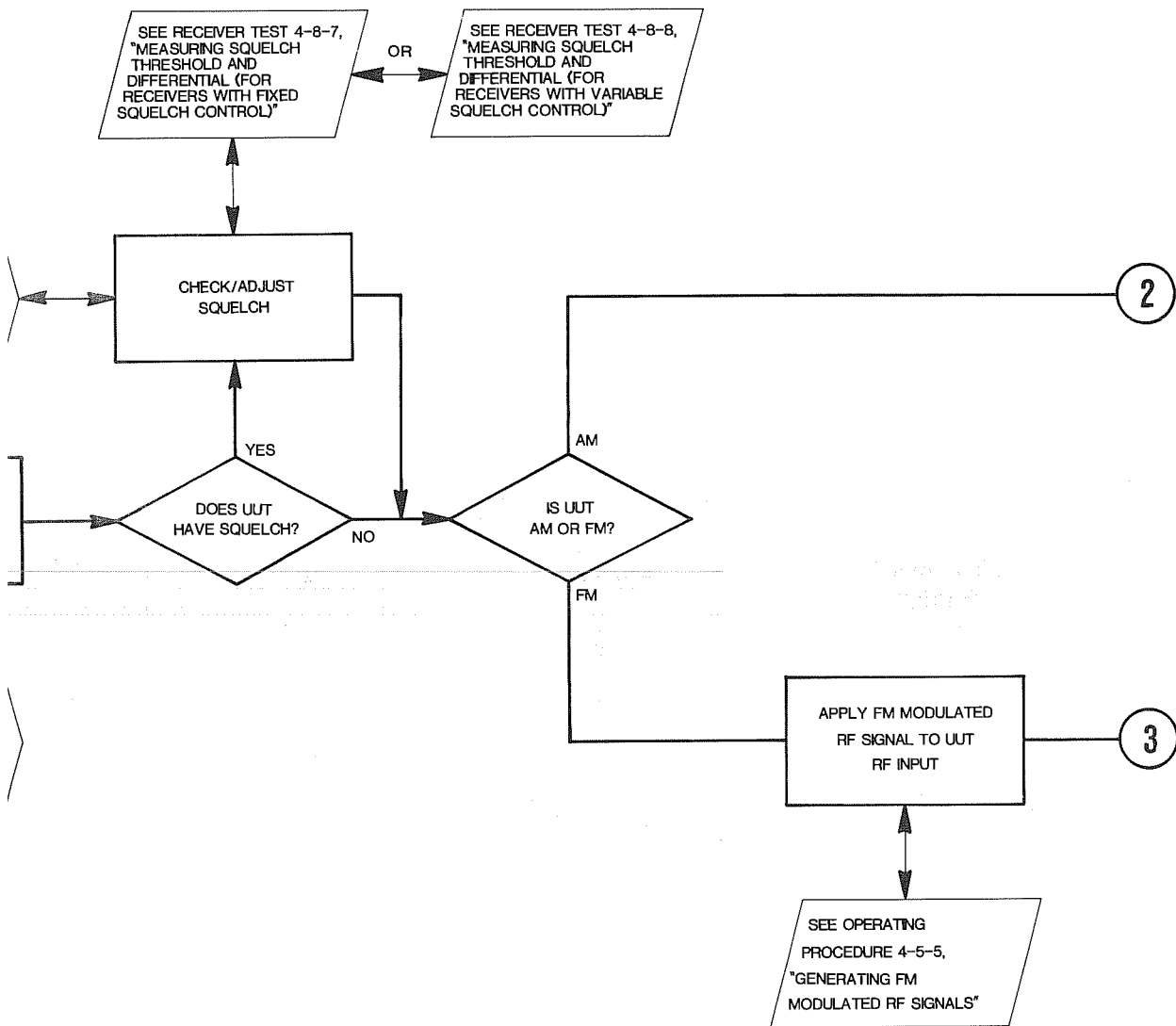

**5-3  
RECEIVER  
ALIGNMENT  
FLOWCHART**

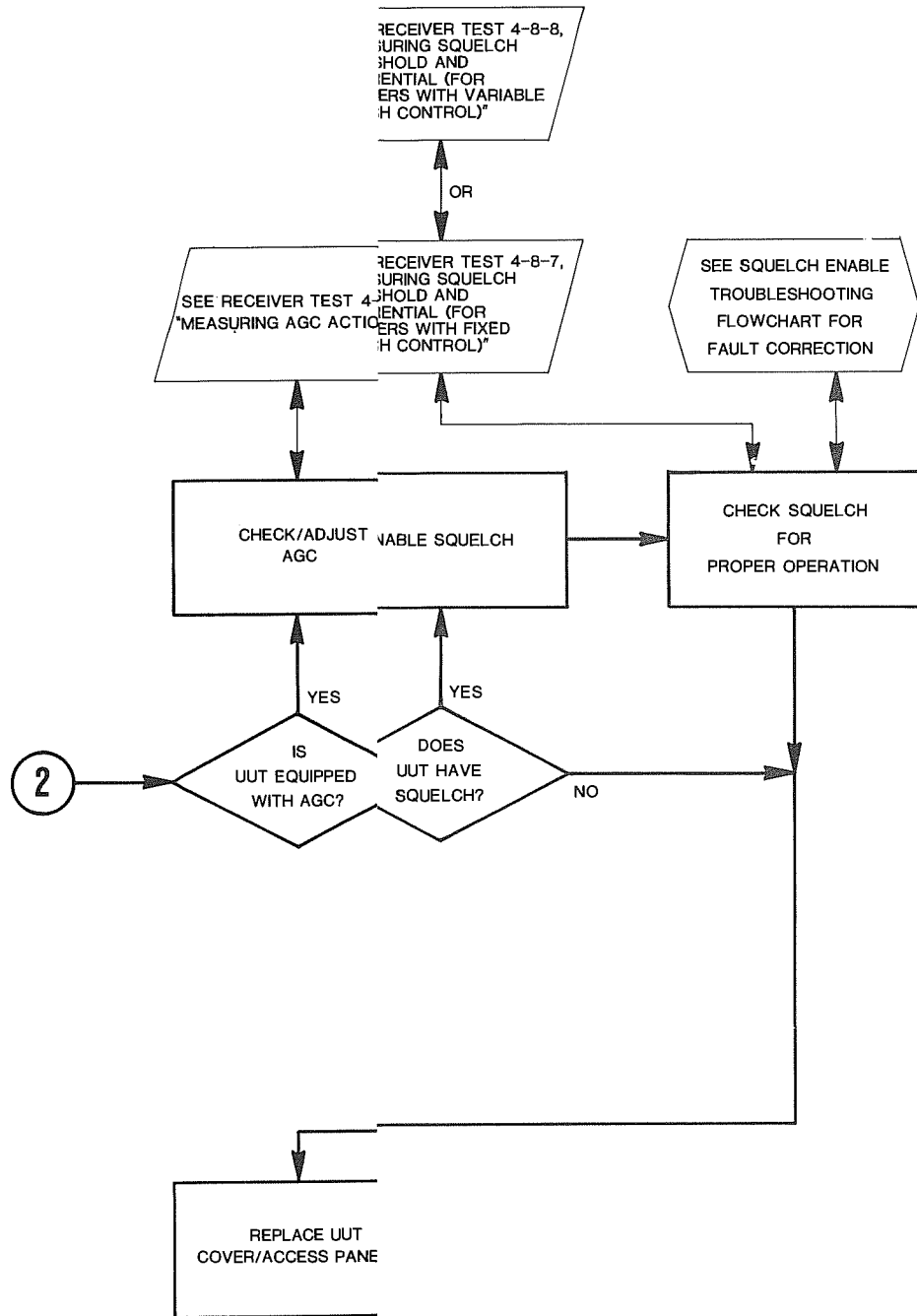

5-1  
**RECEIVER  
 ALIGNMENT  
 FLOWCHART**

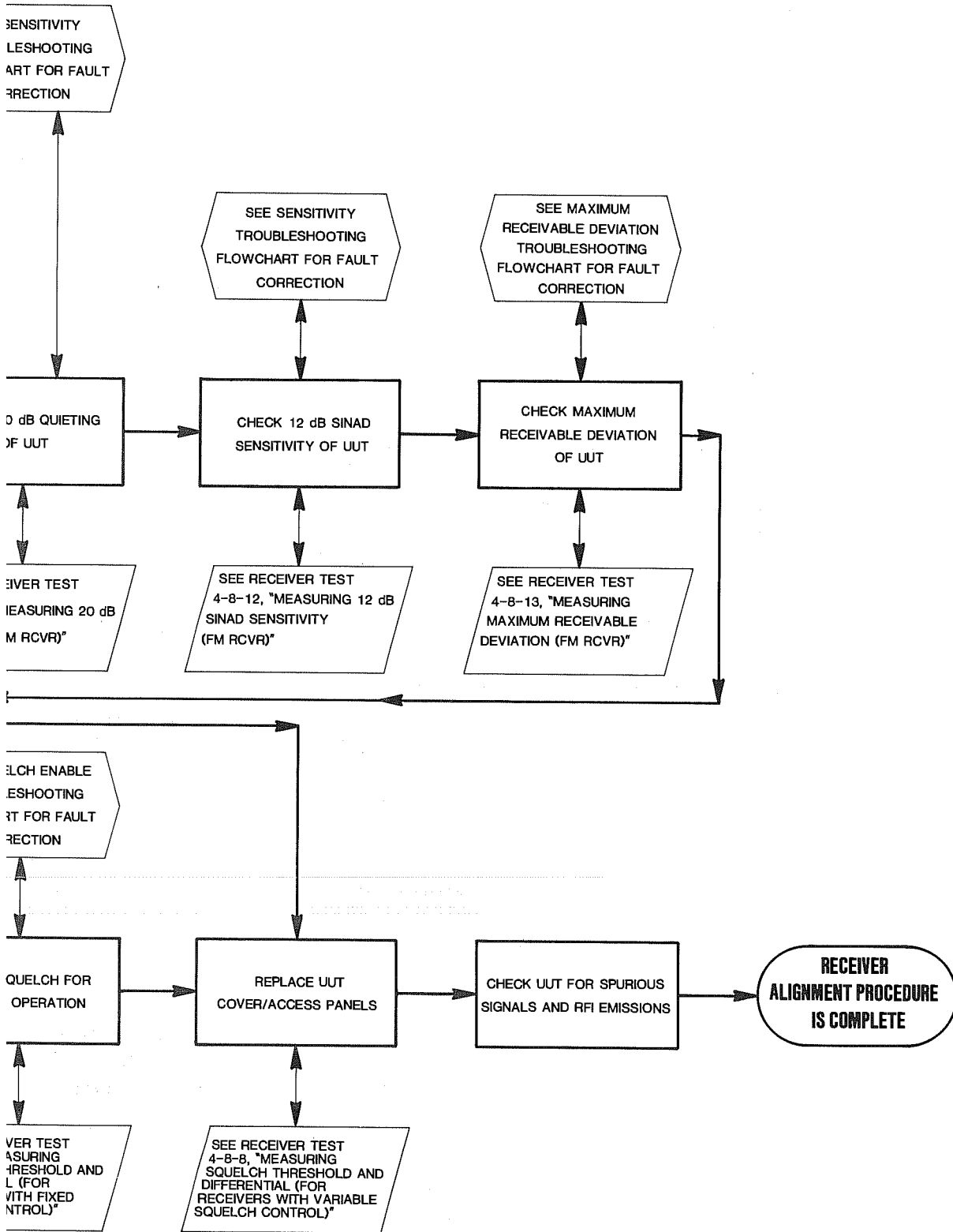

**5-3  
RECEIVER  
ALIGNMENT  
FLOWCHART**

# 5-4 AM/FM RECEIVER TROUBLESHOOTING FLOWCHARTS

## 5-4-1 POWER SUPPLY TROUBLESHOOTING FLOWCHART

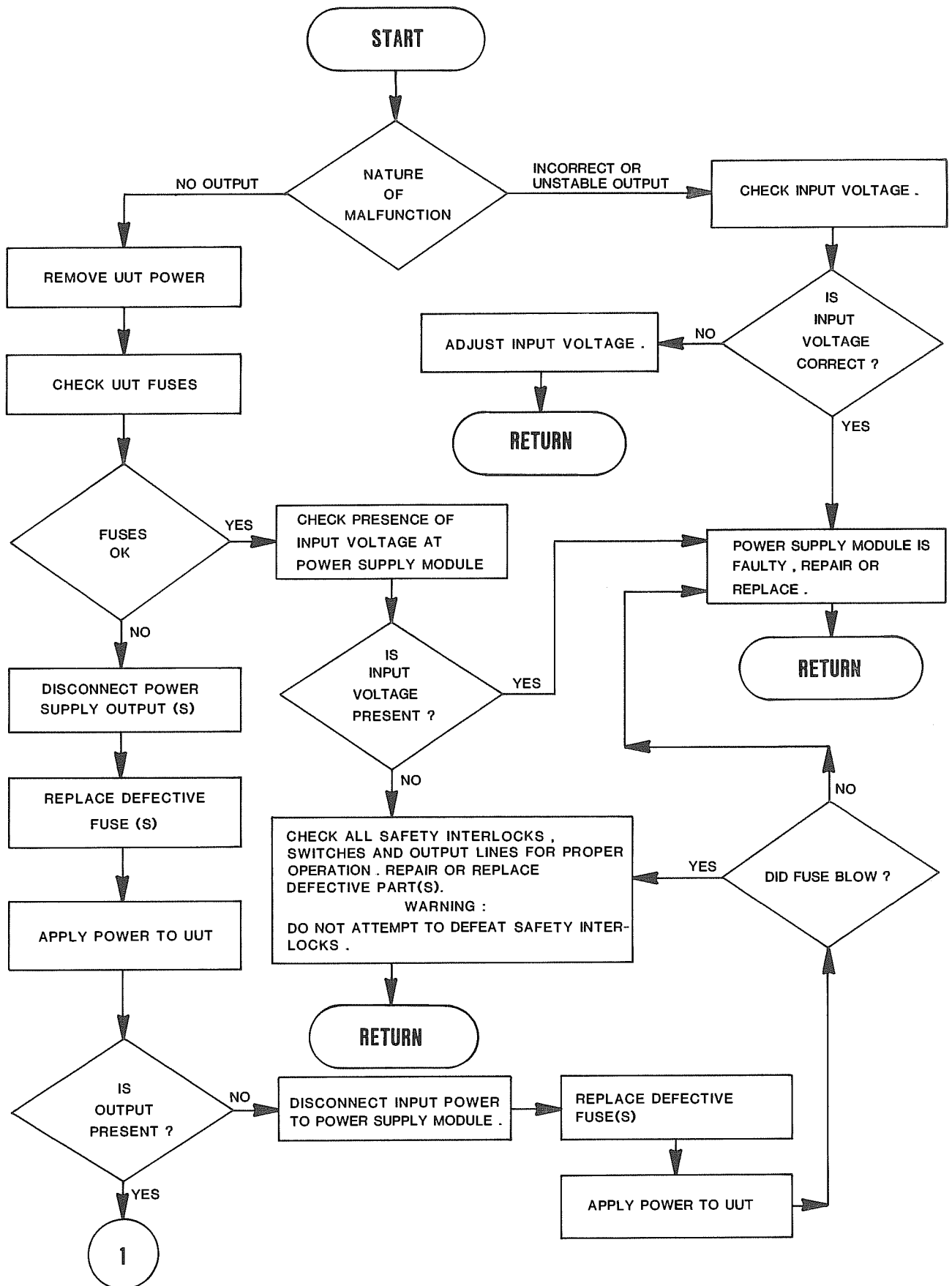

## 5-4-1 POWER SUPPLY TROUBLESHOOTING FLOWCHART

1

IF POWER SUPPLY HAS MULTIPLE OUTPUTS , CONNECT EACH OUTPUT ONE BY ONE UNTIL FUSE BLOWS . THE LAST OUTPUT LINE CONNECTED TO POWER SUPPLY BEFORE FUSE BLOWS IS RESPONSIBLE FOR MALFUNCTION

**WARNING :**

REMOVE POWER AND DISCHARGE ALL FILTER CAPACITORS BEFORE RECONNECTING OUTPUT LINE(S) TO POWER SUPPLY .

**CAUTION :**

ALWAYS CONNECT APPLICABLE OUTPUT LINES IN FOLLOWING ORDER :

- 1 . CONTROL OUTPUT LINE(S)
- 2 . BIAS OUTPUT LINE(S)
- 3 . LOGIC OUTPUT LINE(S)
- 4 . LOWER VOLTAGE OUTPUT LINE(S)
- 5 . HIGHER VOLTAGE OUTPUT LINE(S)

REMOVE UUT POWER

CHECK UUT SCHEMATICS TO DETERMINE WHICH SUB-ASSEMBLIES AND/OR PC BOARDS USE OUTPUT LINE(S) RESPONSIBLE FOR BLOWING FUSE(S) . REMOVE THESE ASSEMBLIES/PC BOARDS FROM UUT.

**WARNING :**

DO NOT ATTEMPT TO DEFEAT ANY SAFETY INTERLOCKS INCORPORATED INTO ANY OF ABOVE SUB-ASSEMBLIES OR PC BOARDS .

APPLY POWER TO UUT

2

## 5-4-1 POWER SUPPLY TROUBLESHOOTING FLOWCHART

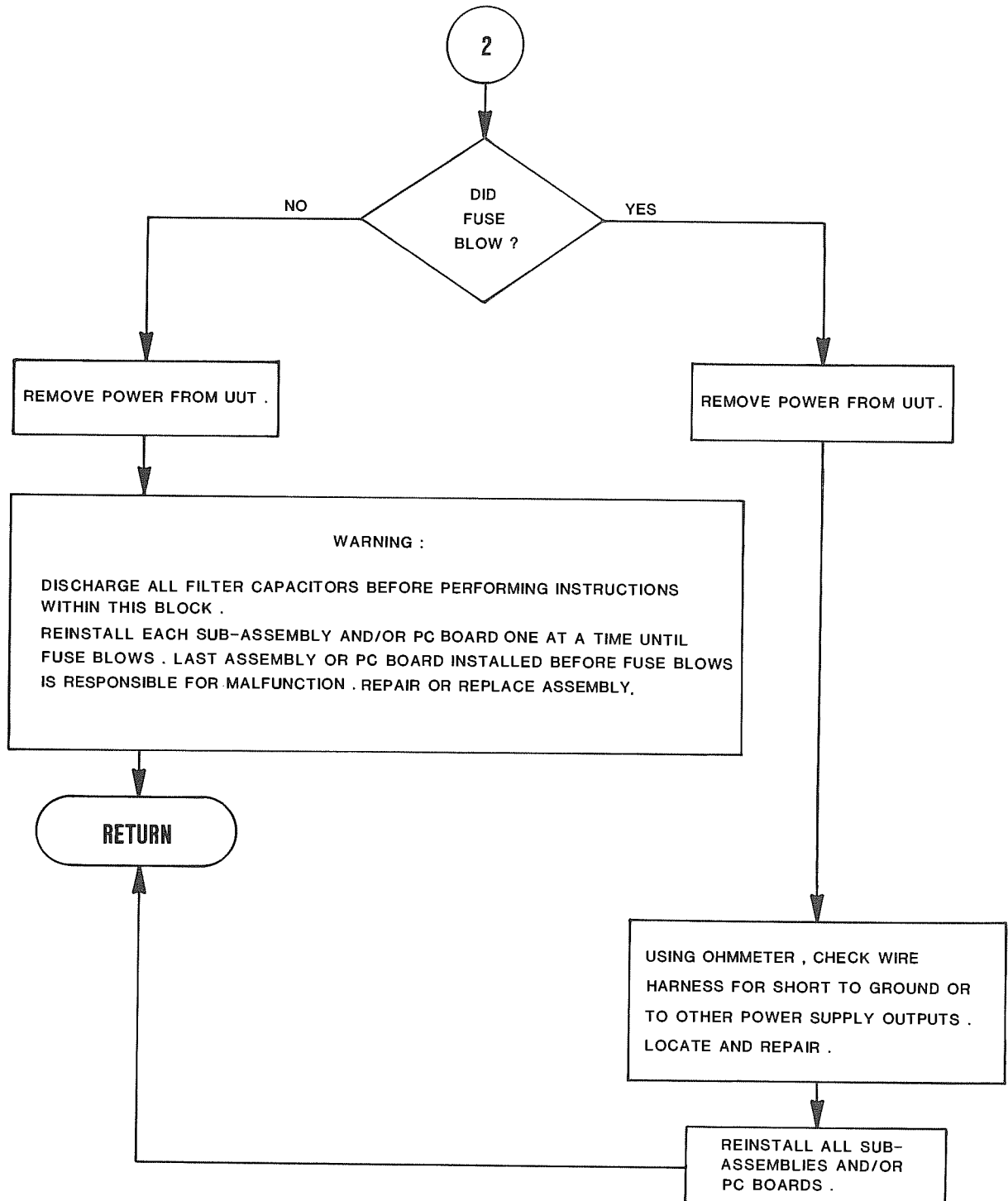





## 5-4-2 OSCILLATOR TROUBLESHOOTING FLOWCHART (REFERENCE TEST PROCEDURE 4-8-2 IN SECTION 4)

NOTE :

OSCILLATOR UNDER TEST MUST BE PHYSICALLY LOCATED ON UUT AND IDENTIFIED ON UUT SCHEMATIC BEFORE PERFORMING TROUBLESHOOTING STEPS BELOW .

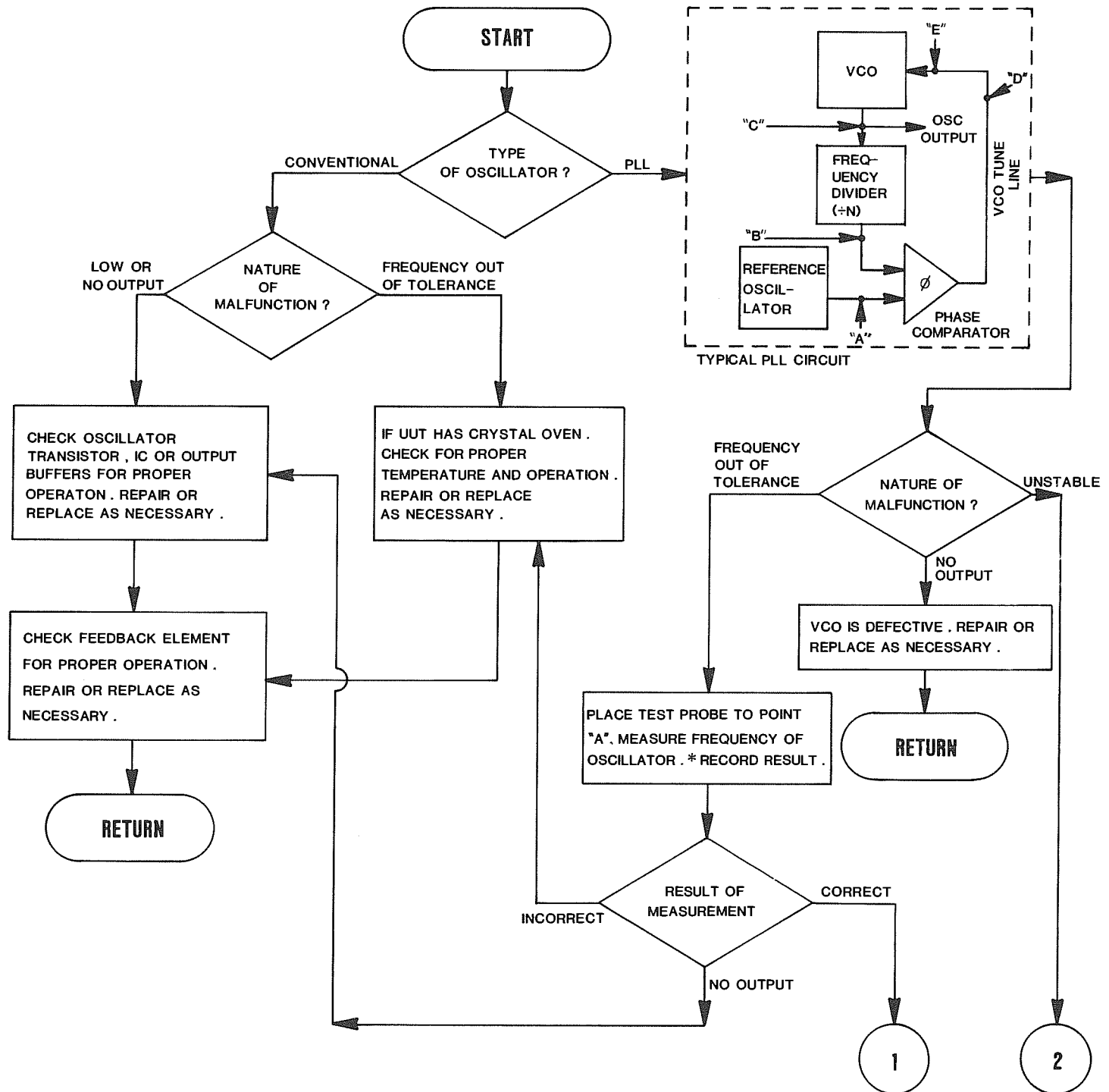

\* CHECK UUT SCHEMATIC FOR OSCILLATOR FREQUENCY RANGE . IF BELOW 50 kHz , MEASURE FREQUENCY USING OPERATING PROCEDURE 4-2-7 "MEASURING FREQUENCIES BETWEEN 5 Hz AND 500 kHz" (STEPS 12 THRU 17) . IF ABOVE 50 kHz , MEASURE FREQUENCY USING FREQUENCY COUNTER .

## 5-4-2 OSCILLATOR TROUBLESHOOTING FLOWCHART

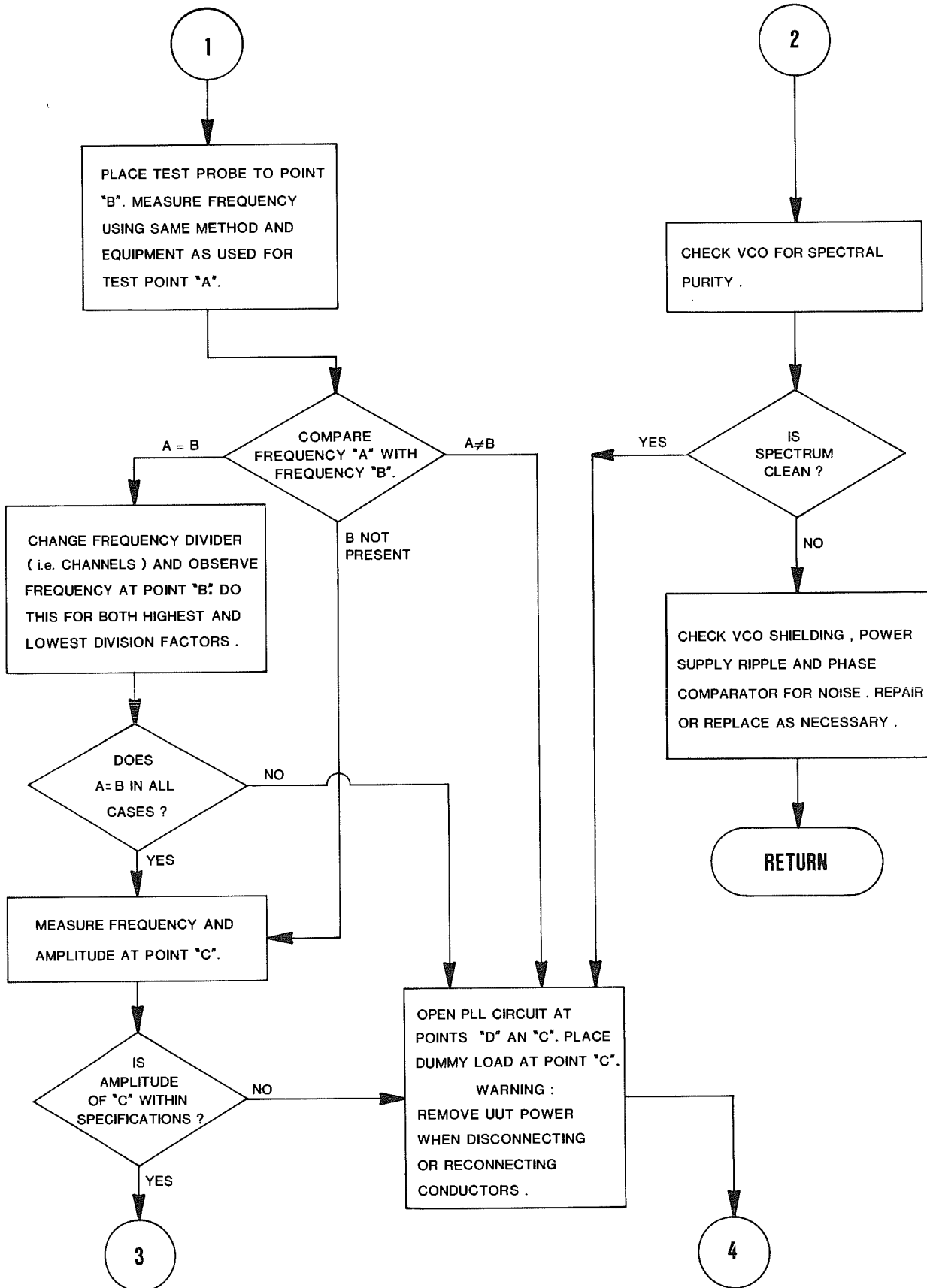

## 5-4-2 OSCILLATOR TROUBLESHOOTING FLOWCHART

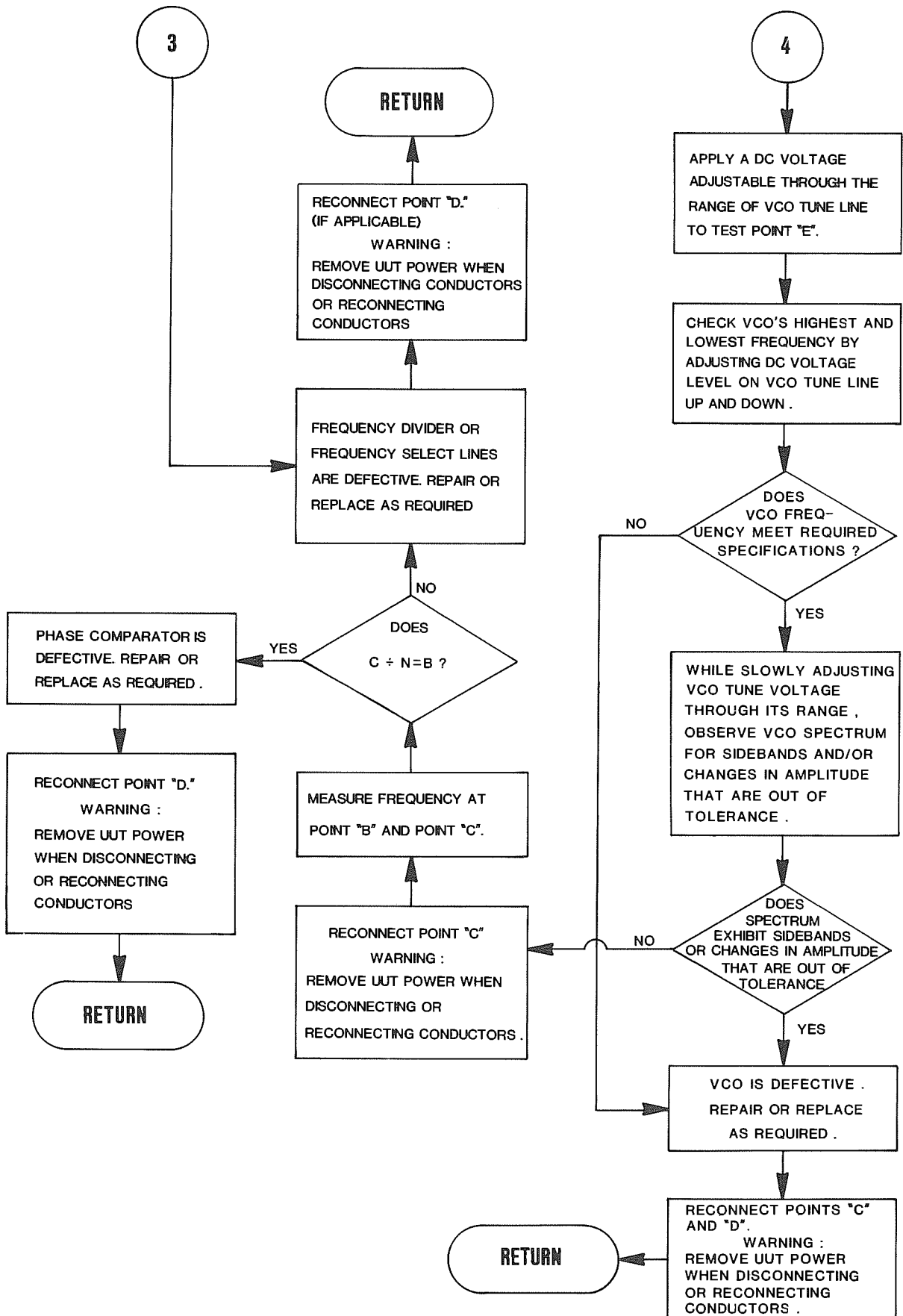



### 5-4-3 RF AMPLIFIER TROUBLESHOOTING FLOWCHART (REFERENCE TEST PROCEDURE 4-8-3 IN SECTION 4)

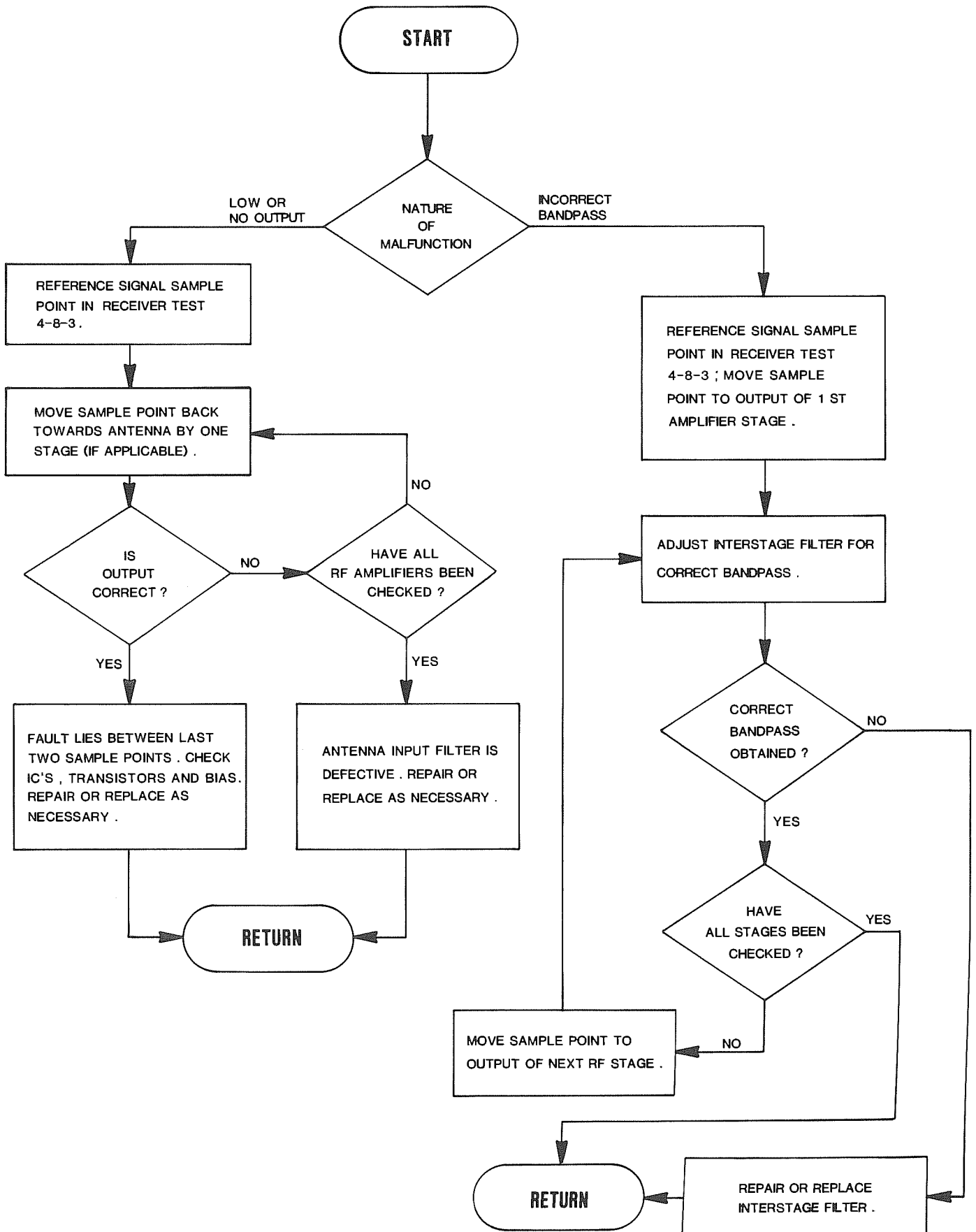



**5-4-4 IF AMPLIFIER TROUBLE SHOOTING FLOWCHART**  
 (REFERENCE TEST PROCEDURE 4-8-4 IN SECTION 4)

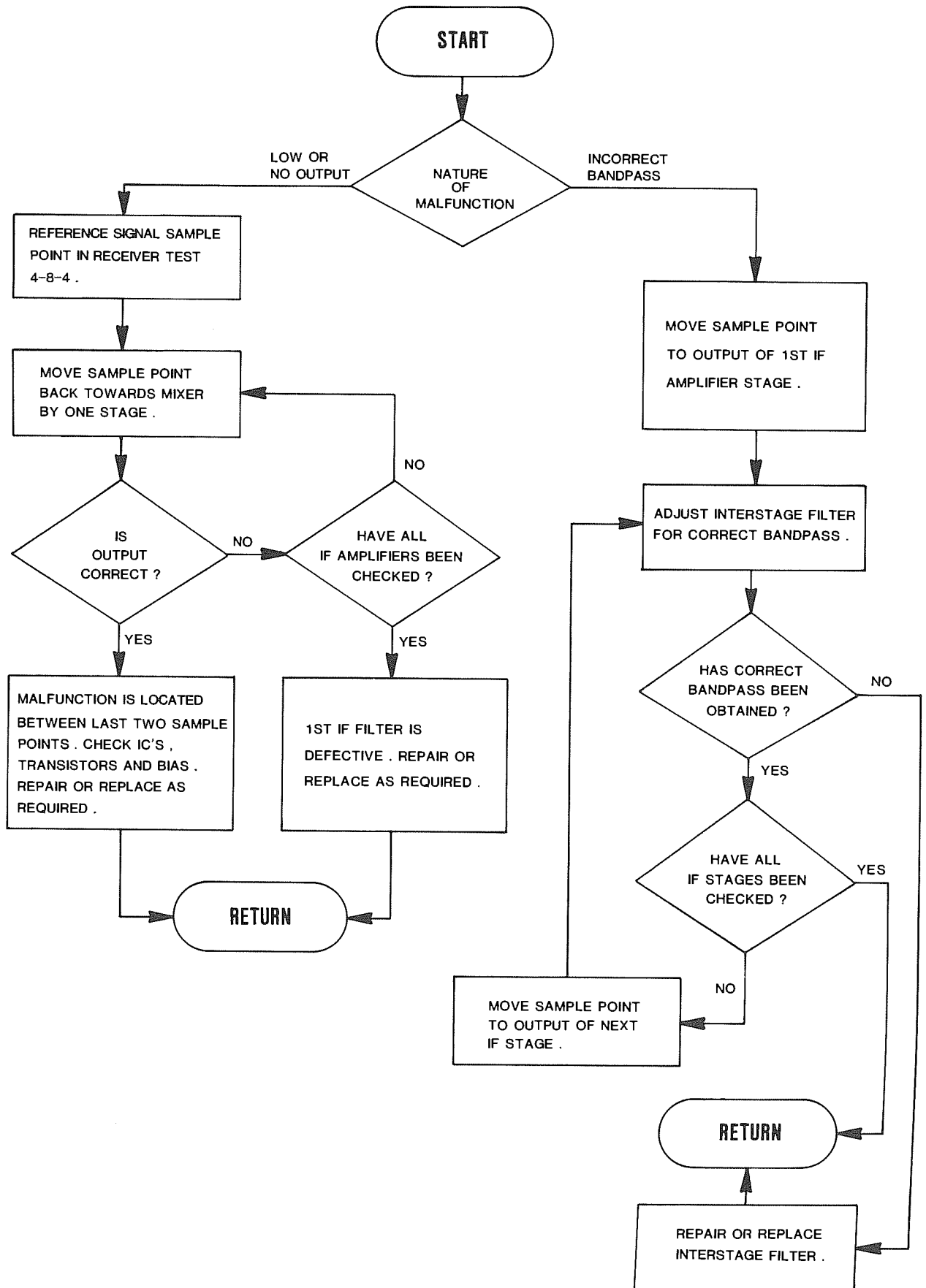





**5-4-5 RECEIVER SECTION TROUBLESHOOTING FLOWCHART**  
**(REFERENCE TEST PROCEDURE 4-8-5 IN SECTION 4)**

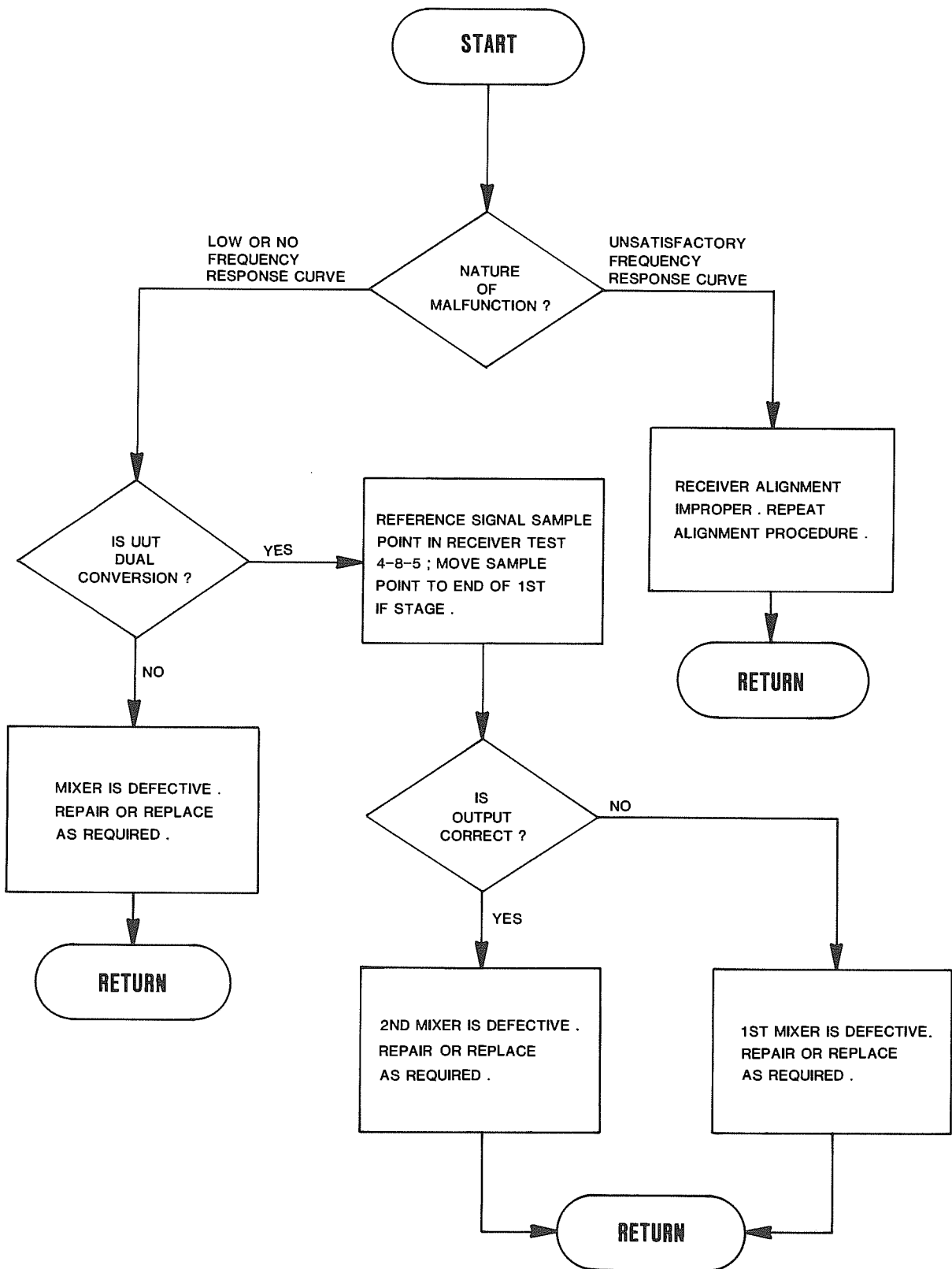



**5-4-6 SQUELCH TROUBLESHOOTING FLOWCHART**  
(REFERENCE TEST PROCEDURES 4-8-7 OR 4-8-8 IN SECTION 4

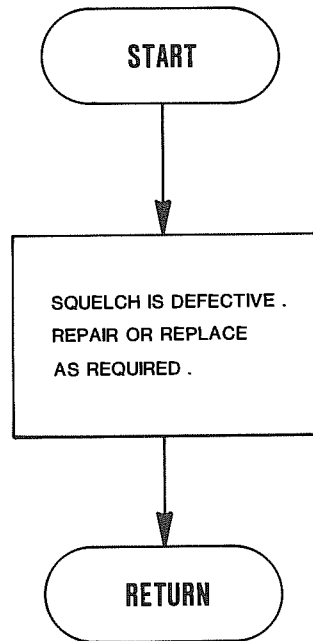



**5-4-7 AGC TROUBLESHOOTING FLOWCHART**  
(REFERENCE TEST PROCEDURE 4-8-9 IN SECTION 4)

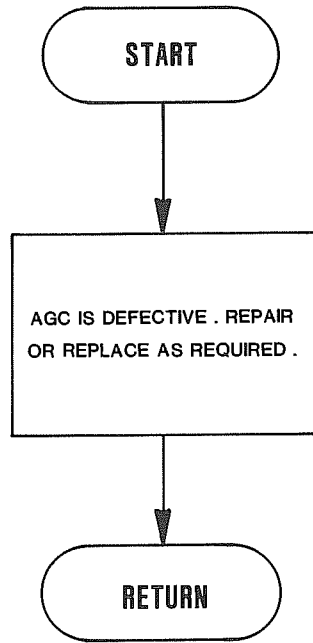



## 5-4-8 AM AUDIO TROUBLESHOOTING FLOWCHART

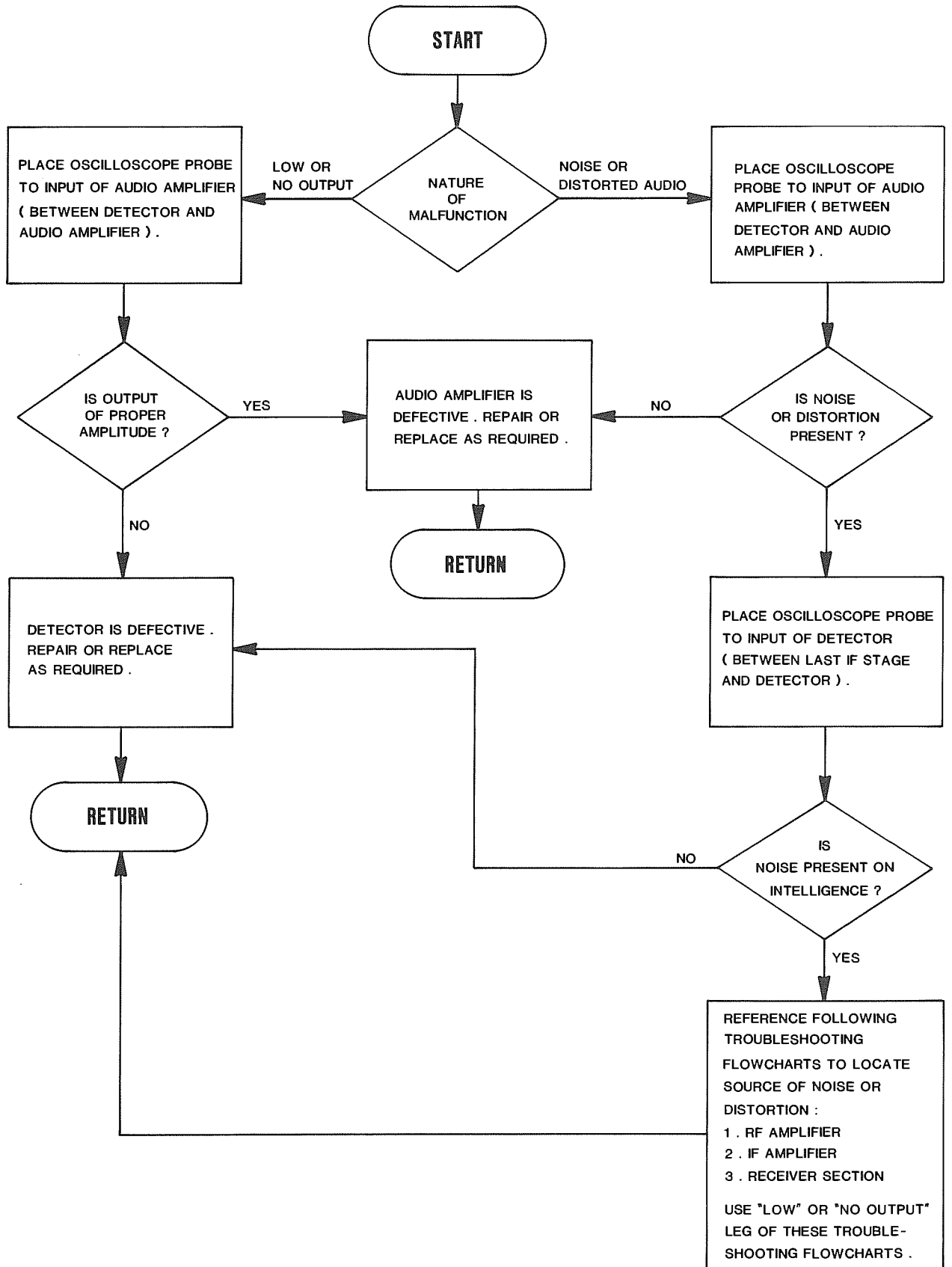





**5-4-9 SENSITIVITY TROUBLESHOOTING FLOWCHART**  
 (REFERENCE TEST PROCEDURES 4-8-10, 4-8-11 OR 4-8-12 IN SECTION 4)

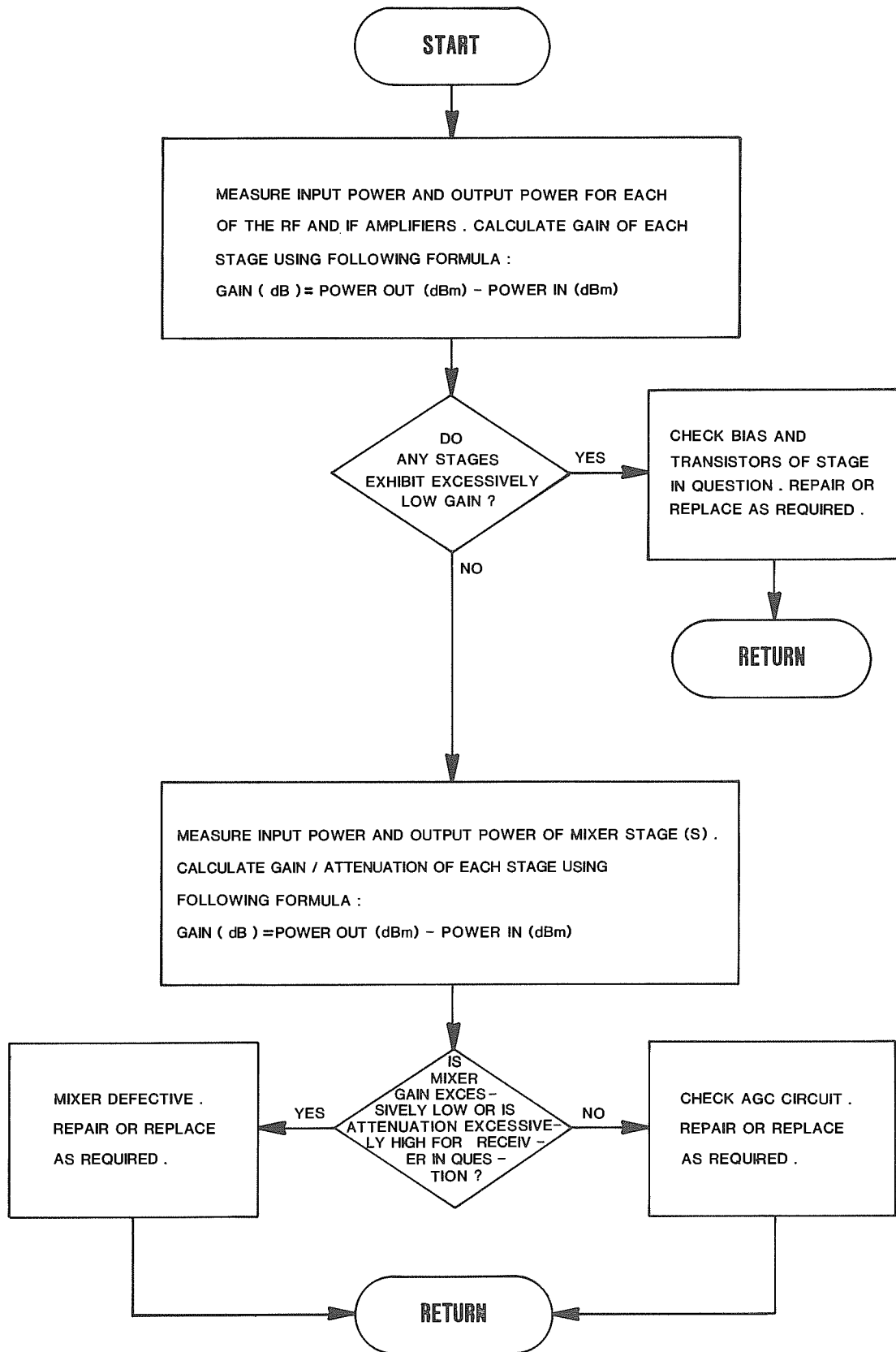



**5-4-10 SQUELCH ENABLE TROUBLESHOOTING FLOWCHART**  
(REFERENCE TEST PROCEDURE 4-8-7 OR 4-8-8 IN SECTION 4)

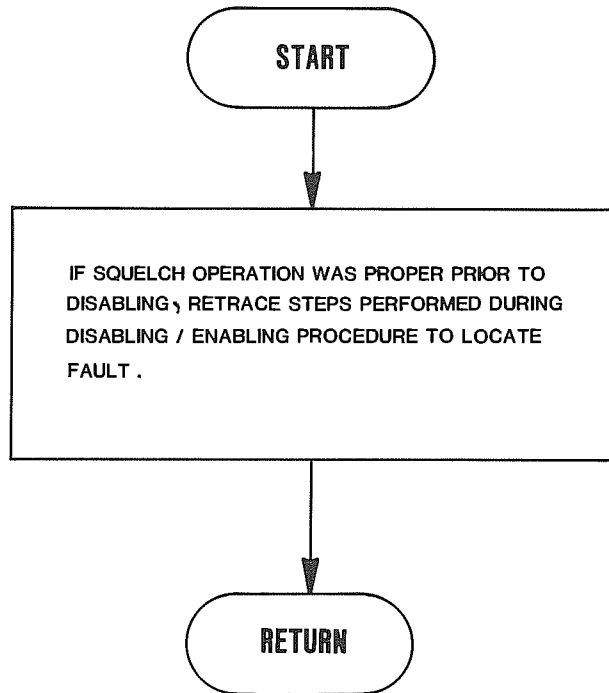



## 5-4-11 FM AUDIO TROUBLESHOOTING FLOWCHART

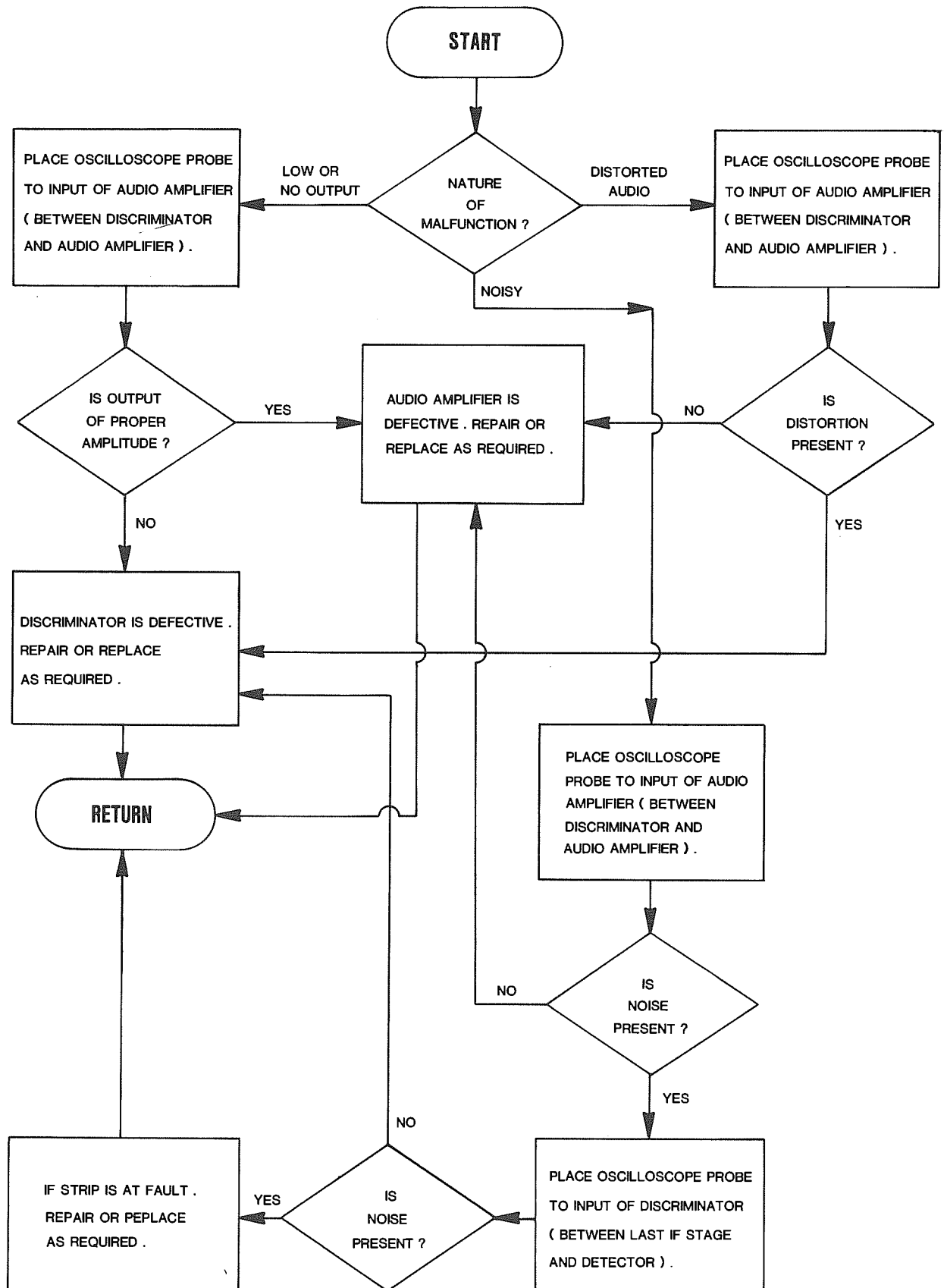



**5-4-12 MAXIMUM RECEIVABLE DEVIATION TROUBLESHOOTING FLOWCHART  
(REFERENCE TEST PROCEDURE 4-8-13 IN SECTION 4)**

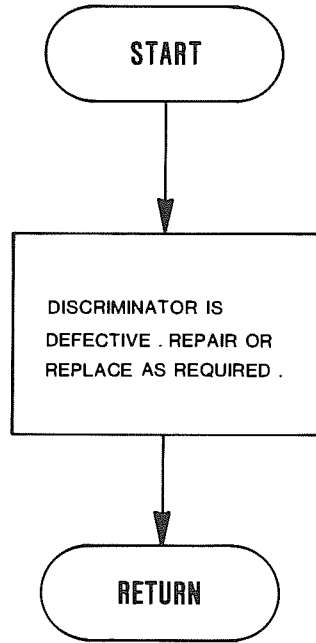





# APPENDICES

## APPENDIX A: SPECIFICATIONS FM/AM-1000S (EFF: S/N 1616 & ON)

### RF SIGNAL GENERATOR

FREQUENCY RANGE:	100 Hz to 999.9999 MHz in 100 Hz increments
FREQUENCY ACCURACY:	$5 \times 10^{-7}$ ( $\pm 0.00005\%$ ) $2 \times 10^{-7}$ (typically) (See specification on TCXO MASTER OSCILLATOR)
FM QUIETING:	42 dB below 3.3 kHz deviation at 1 kHz rate, as measured in a 0.3 to 3 kHz post detection bandwidth
RESIDUAL FM:	Less than 100 Hz
RF OUTPUT POWER*:	-130 dBm to -33 dBm (100 Hz to 1 GHz), -130 dBm to 0 dBm (20 kHz to 1 GHz); continuously variable into $50\Omega$
RANGES:	"Normal" " $\mu V \times 100$ " and "HIGH LEVEL" (0 dBm)
ACCURACY*:	-110 to -35 dBm $\pm 2.5$ dB up to 400 MHz, $\pm 3.0$ dB above 400 MHz
"HI LEVEL" POWER RANGE INDICATOR ACCURACY:	0 dBm; $\pm 2.5$ dB (20 kHz to 600 MHz), $\pm 4.0$ dB (600 MHz to 999.9999 MHz) Dial indicator accuracy (dBm scale) is maintained relative to 0 dBm indication
INTERNAL MODULATION	
AM:	10 Hz to 5 kHz (0 to 90%)
FM:	10 Hz to 9999.9 Hz rate (0 to $\pm 15$ kHz deviation)
EXTERNAL MODULATION	
AM:	3.0 V ( $\pm 1$ V) peak-to-peak produces 90% modulation
FM:	6.0 V ( $\pm 2$ V) peak-to-peak produces 15 kHz deviation (maximum modulating frequency = 15 kHz)

\* These specifications may not be complied with at certain frequencies, as a result of the internal design of the unit.

## APPENDIX A (CONT'D)

### OSCILLOSCOPE

DISPLAY SIZE: 5 x 5 cm  
VERTICAL BANDWIDTH: DC to 1 MHz (at 3 dB bandwidth)  
EXTERNAL VERTICAL  
INPUT RANGES: 10 mV, 100 mV, 1 V, 10 V per division  
HORIZONTAL SWEEP RATE: 10 mSec, 1 mSec, 100  $\mu$ Sec, 10  $\mu$ Sec per  
division

### SPECTRUM ANALYZER

DYNAMIC RANGE: 70 dB (-30 dBm to -100 dBm)  
DISPERSION: Continuous from  $\pm 0.5$  MHz to  $\pm 5$  MHz from  
center frequency (1 to 10 MHz span)  
BANDWIDTH RESOLUTION: 30 kHz

### AUDIO GENERATOR

OPERATING MODE  
Internal: Variable frequency generator or 1 kHz  
tone, or both simultaneously  
External and Internal\*: Any external tone(s) plus either or both  
internal tones simultaneously  
FREQUENCY RANGE  
Variable Tone: 10.0 Hz to 9999.9 Hz  
Fixed Tone: 1 kHz  
ACCURACY  
Fixed Tone:  $\pm 20$  Hz  
Variable Tone: 0.01%  
Resolution: 0.1 Hz  
OUTPUT LEVEL: 0 to 2.5 V RMS minimum for either tone  
into 150 $\Omega$

\* RF Generator may be modulated simultaneously from internal and external sources, and internal variable frequency generator may be externally keyed for sequential tone coding.

## APPENDIX A (CONT'D)

### AUDIO GENERATOR (cont'd)

DISTORTION  
10 Hz to 100 Hz: 2% maximum  
100 Hz to 9999.9 Hz: 0.7% maximum  
Fixed Tone: 2% maximum

### RECEIVER/MONITOR

FREQUENCY RANGE: 300 kHz to 999.9999 MHz  
RESOLUTION: 100 Hz  
10 dB SINAD  
SENSITIVITY: 2  $\mu$ V (typical)  
SELECTIVITY AT 3 dB POINT  
Narrow: Receiver 15 kHz; detector audio bandwidth is 8 kHz  
Mid: Receiver 150 kHz; detector audio bandwidth is 8 kHz  
Wide: Receiver 150 kHz; detector audio bandwidth is 80 kHz  
Quieting: Deviation measurements can be made down to 0.1 kHz  
ADJACENT CHANNEL  
REJECTION: Greater than 25 dB at  $\pm 25$  kHz (typically)  
Greater than 40 dB at  $\pm 50$  kHz (typically)  
BEAT FREQUENCY  
OSCILLATOR (BFO): Variable injection level  
BEAT FREQUENCY  
OSCILLATOR ACCURACY:  $\pm 3$  dB, from 2  $\mu$ V to 5000  $\mu$ V. BFO is phaselocked to master oscillator  
DEMODULATION OUTPUT LEVEL  
AM: 100% = 0.47 V peak-to-peak nominal  
FM:  $\pm 10$  kHz = 0.65 V peak-to-peak nominal  
RECEIVER ANTENNA  
INPUT PROTECTION: 0.25 watts maximum level without damage

## APPENDIX A (CONT'D)

### POWER MONITOR

FREQUENCY RANGE: 1 MHz to 1000.00 MHz

POWER RANGES: 0 to 10 and 0 to 100 watts

ACCURACY  
1 to 600 MHz:  $\pm 7\%$  of reading plus 3% of full scale  
600 to 1000.00 MHz:  $\pm 20\%$  of reading plus 3% of full scale

INPUT POWER: 20 watts continuous;  
100 watts for 10 seconds

AUTOMATIC MODE SWITCHING: Automatic changeover from generate to monitor mode at 100 mW (typical) input to TRANS/RCVR Connector

### TCXO MASTER OSCILLATOR

ACCURACY:  $5 \times 10^{-7}$  ( $\pm 0.00005\%$ ),  
 $2 \times 10^{-7}$  (typically)  
Greater accuracy is attainable with front panel adjustment to WWV.

AGING STABILITY: 2 to 3 PPM during first year;  
1 PPM per year thereafter

### FREQUENCY ERROR METER MEASUREMENT CAPABILITY

METER SENSITIVITY: Typically 1.5  $\mu$ V above 1 MHz (sensitivity is reduced below 1 MHz)

RANGES:  $\pm 1.5$  kHz,  $\pm 5$  kHz,  $\pm 15$  kHz (full scale)

RESOLUTION: 50 Hz (calibration marks at 100 Hz on  $\pm 1.5$  kHz range)

ZEROING: Frequency error meter is automatically zeroed every 1.5 seconds during a 3 mSec time period. Auto zeroing may be disabled with AUTO-ZERO/BATT switch.

### TONE FREQUENCY MONITORING

MEASUREMENT TECHNIQUES: Internal tone is selectable with the oscilloscope SWEEP CONTROL to produce a Lissajou oscilloscope pattern from a received signal.

## APPENDIX A (CONT'D)

### GENERAL

DIMENSIONS:	12.5" Wide, 8" High, 19.5" Deep (31.8 cm W, 20.3 cm H, 49.5 cm D)
WEIGHT:	43 lbs. (19.5 kg)
OPERATING TEMPERATURE RANGE:	32° F to 122° F (0° to 50° C)
POWER REQUIREMENTS:	115/230 V AC 50 to 400 Hz 11 to 28 V DC
TYPICAL DC CURRENTS:	4.3 A at 12 V and 1.85 A at 28 V (With Oscilloscope/Receiver "ON" and Dual Tone Generator/Spectrum Analyzer "OFF".)
TYPICAL POWER CONSUMPTION:	80 W
INTERNAL BATTERY:	12 V DC 5.0 amp-hr

### **NOTE**

- Maximum ON time for measurement of transmitter output using the TRANS/RCVR Connector (7) is:
  - 10 sec at 100 W, 15% duty cycle
  - 20 sec at 50 W, 30% duty cycle
  - 2 min at 30 W, 50% duty cycle
- Specifications and features subject to change without notice.



## APPENDIX B: FM/AM-1000S STANDARD/OPTIONAL ACCESSORIES

### B-1 STANDARD ACCESSORY LIST

Qty.	Description/Function	Model No.	IFR Part No.
1	<u>Allen Wrench, .05"</u> For use in loosening/tightening FM/AM-1000S control knobs.	N/A	1025-0000-107
1	<u>Antenna</u> For attachment to ANT INPUT Connector (44) when monitoring "off-the-air" signals.	N/A	1201-7616-500
1	<u>AC Power Cord</u> For use in powering FM/AM-1000S from standard AC power sources.	N/A	6041-2326-602
1	<u>DC Power Cord (w/cigar lighter adaptor)</u> For use in powering FM/AM-1000S from 12 volt DC power sources.	N/A	6041-2326-601
1	<u>90° Angle BNC Connector (Male to Female)</u> For use in pointing antenna skyward when FM/AM-1000S is set into a horizontal operating position.	N/A	2113-0000-013
1	<u>Fuse, 1¼ Ampere, SLO BLO</u> Replacement fuse for FM/AM-1000S AC line fuse.	N/A	5106-0000-005
2	<u>Fuse, 7½ Ampere</u> Replacement fuses for FM/AM-1000S battery or external DC fuses.	N/A	5106-0000-009

### B-2 OPTIONAL ACCESSORY LIST

Qty.	Description/Function	Model No.	IFR Part No.
1	<u>Canvas Cover/Carrying Case</u> FM/AM-1000S protective carrying case with three built-in compartments for accessories.	CS-114	1412-2380-700



## APPENDIX B (CONT'D)

### B-2 OPTIONAL ACCESSORY LIST (cont'd)

Qty.	Description/Function	Model No.	IFR Part No.
1	<u>MM-100 Multimeter w/PB-114 Probe</u> Self contained 8 function multi-meter incorporated into FM/AM-1000S lid; includes "x 1" and "x 10" test probe (600 V RMS, 800 VDC)	MM-100	9001-2381-600
1	<u>Fuse, 1/32 Ampere</u> Replacement fuse for MM-100 Multi-meter ohms circuit	N/A	5106-4500-031
1	<u>10 dB BNC Attenuator, 1 Watt</u>	AT-10	2901-0401-010
1	<u>20 dB BNC Attenuator, 1 Watt</u>	AT-20	2901-0401-020
1	<u>30 dB BNC Attenuator, 2 Watt</u>	AT-30	2901-0402-030
1	<u>10 dB BNC Type N Attenuator, 150 Watt</u>	AT-4010	2901-0680-010
1	<u>10 dB BNC Type N Attenuator, 150 Watt, w/coax cable assy.</u>	AT-4010A	7005-2381-100
1	<u>Coax Assembly, Flexible, 150 Watt</u> For use in connecting AT-4010 150 Watt Attenuator to FM/AM-1000S.	CA-114	6053-0450-600
1	Antenna (Telescopic)	ANT-2	1201-0909-900

## APPENDIX C: dBm TO MICROVOLT CONVERSION CHART

dBm	$\mu\text{V}$	dBm	$\mu\text{V}$	dBm	$\mu\text{V}$
0	224,000	-47	1,000	-94	4.47
-1	200,000	-48	891	-95	3.99
-2	178,000	-49	795	-96	3.55
-3	159,000	-50	709	-97	3.17
-4	141,000	-51	633	-98	2.82
-5	126,000	-52	563	-99	2.52
-6	112,000	-53	501	-100	2.24
-7	100,000	-54	447	-101	2.00
-8	89,100	-55	399	-102	1.78
-9	79,500	-56	355	-103	1.59
-10	70,900	-57	317	-104	1.41
-11	63,300	-58	282	-105	1.26
-12	56,300	-59	252	-106	1.12
-13	50,100	-60	224	-107	1.00
-14	44,700	-61	200	-108	0.891
-15	39,900	-62	178	-109	0.795
-16	35,500	-63	159	-110	0.709
-17	31,700	-64	141	-111	0.633
-18	28,200	-65	126	-112	0.563
-19	25,200	-66	112	-113	0.501
-20	22,400	-67	100	-114	0.447
-21	20,000	-68	89.1	-115	0.399
-22	17,800	-69	79.5	-116	0.355
-23	15,900	-70	70.9	-117	0.317
-24	14,100	-71	63.3	-118	0.282
-25	12,600	-72	56.3	-119	0.252
-26	11,200	-73	50.1	-120	0.224
-27	10,000	-74	44.7	-121	0.200
-28	8,900	-75	39.9	-122	0.178
-29	7,950	-76	35.5	-123	0.159
-30	7,090	-77	31.7	-124	0.141
-31	6,330	-78	28.2	-125	0.126
-32	5,630	-79	25.2	-126	0.112
-33	5,010	-80	22.4	-127	0.100
-34	4,470	-81	20.0	-128	0.0891
-35	3,990	-82	17.8	-129	0.0795
-36	3,550	-83	15.9	-130	0.0709
-37	3,170	-84	14.1	-131	0.0633
-38	2,820	-85	12.6	-132	0.0563
-39	2,520	-86	11.2	-133	0.0501
-40	2,240	-87	10.0	-134	0.0447
-41	2,000	-88	8.91	-135	0.0399
-42	1,780	-89	7.95	-136	0.0355
-43	1,590	-90	7.09	-137	0.0317
-44	1,410	-91	6.33	-138	0.0282
-45	1,260	-92	5.63	-139	0.0252
-46	1,120	-93	5.01	-140	0.0224



## APPENDIX D: REPACKING FOR SHIPMENT

### D-1 SHIPPING INFORMATION

IFR test sets returned to factory for calibration, service or repair must be repackaged and shipped subject to the following conditions:

- Do not return any products to factory without first receiving authorization from IFR Customer Service Department.

CONTACT:

Customer Service Dept.  
IFR, Inc.  
10200 West York Street  
Wichita, Kansas 67215

Telephone: (800)-835-2350  
TWX: 910-741-6952

- All test sets must be tagged with:
  - a. Owner's identification and address.
  - b. Nature of service or repair required.
  - c. Model No.
  - d. Serial No.
- Sets must be repackaged in original shipping containers using IFR packing models. If original shipping containers and materials are not available, contact IFR Customer Service Dept. for shipping instructions.
- All freight costs on non-warranty shipments are assumed by customer. (See "Warranty Packet" for freight charge policy on warranty claims.)

### D-2 REPACKING PROCEDURE (Reference - Figure D-1):

1. Make sure bottom packing mold is seated on floor of shipping container.
2. Carefully wrap test set with polyethylene sheeting to protect finish.
3. Place test set into shipping container, making sure set is securely seated in bottom packing mold.
4. Place top packing mold over top of set and press down until mold rests solidly on bottom packing mold.
5. Close shipping container lids and seal with shipping tape or an industrial stapler. Tie all sides of container with break resistant rope, twine or equivalent.

**APPENDIX D (CONT'D)**

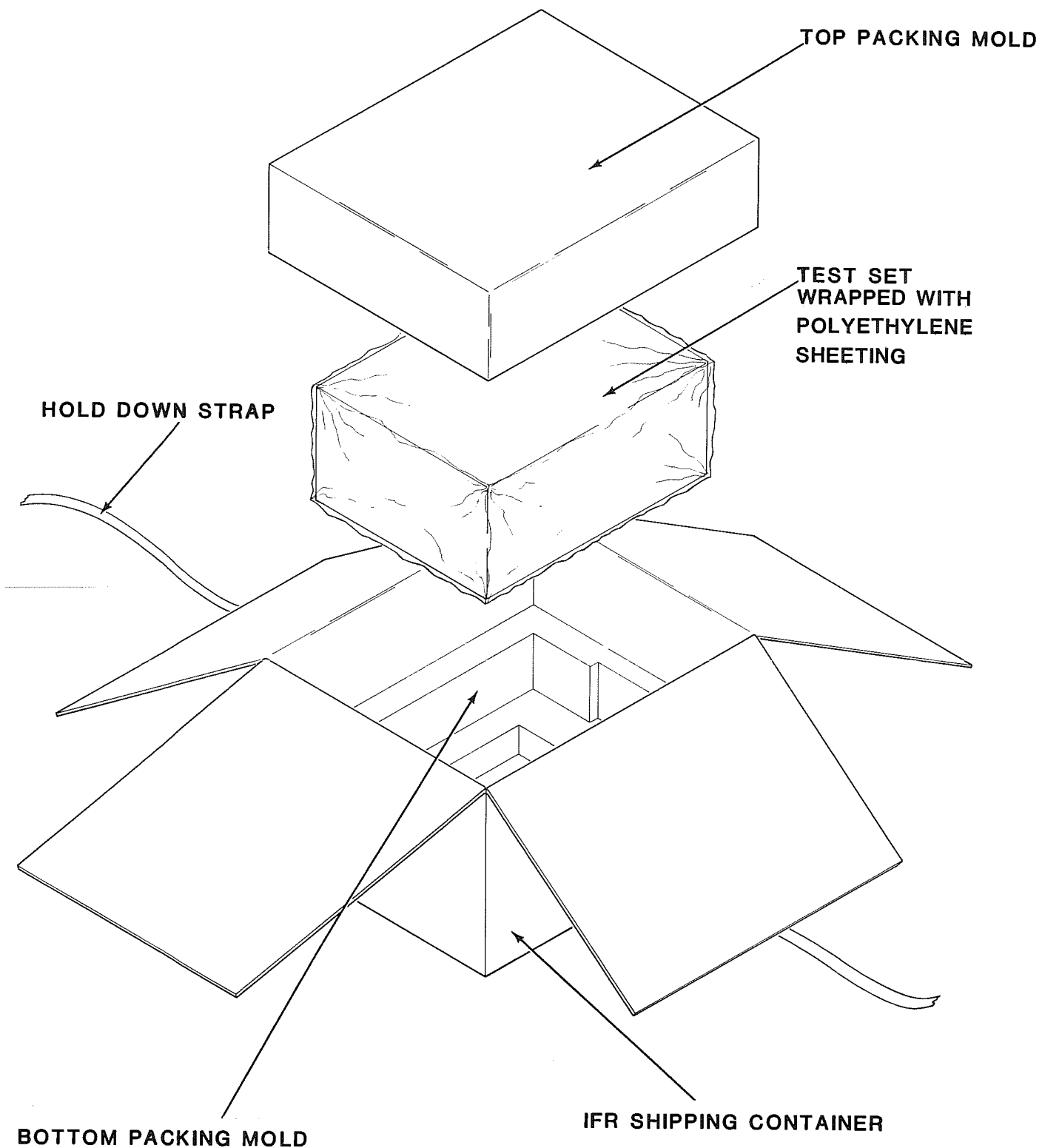
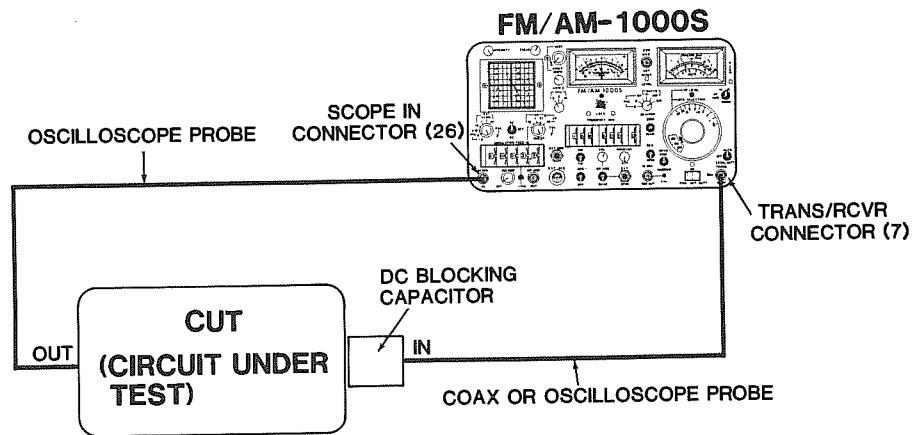

**FIGURE D-1 REPACKING FOR SHIPMENT**

**APPENDIX E: SWEEP GENERATOR/TRACKING OSCILLOSCOPE OPERATION  
(Viewing frequency response display directly on oscilloscope w/o use of detector)**

When maximum frequency to be swept is below 1 MHz, operator may view frequency response curve directly on FM/AM-1000S oscilloscope, without use of a detector. If this is done, the frequency response display will appear slightly different from the display obtained when using a detector. The examples below provide comparisons between the frequency response displays using the two different viewing methods. This information should be useful in interpreting the significant characteristics of the displays.

TEST SET-UP  
DIAGRAM: To view frequency response envelope directly on oscilloscope (w/o use of detector), equipment set-up must be made as shown:

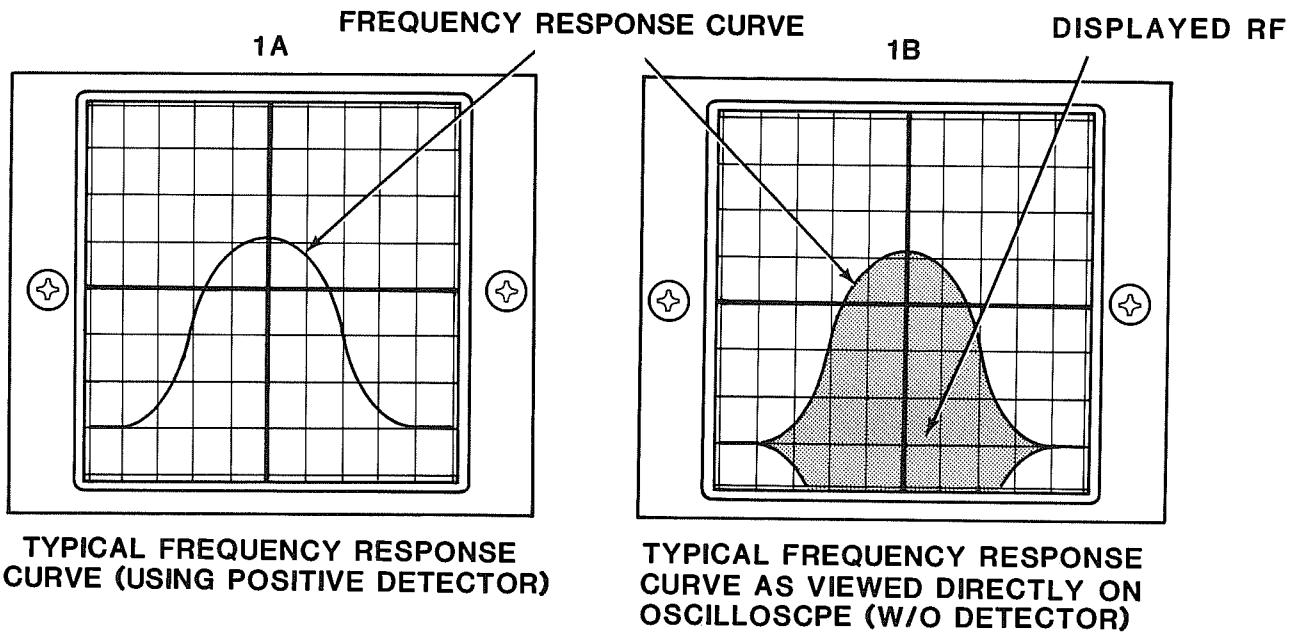

**FIGURE E-1 TEST SET-UP DIAGRAM FOR VIEWING FREQUENCY RESPONSE CURVE DIRECTLY ON FM/AM-1000S OSCILLATOR OSCILLOSCOPE**

**APPENDIX E (CONT'D)**

TEST SET-UP  
DIAGRAM: (cont'd)

EXAMPLES:



**FIGURE E-2 FREQUENCY RESPONSE CURVE COMPARISON (AS VIEWED ON OSCILLOSCOPE WITH AND WITHOUT USE OF DETECTOR)**

Note similarities between examples 1A & 1B above. When viewing frequency response curve directly on oscilloscope (w/o detector), operator should be concerned with response curve only; any displayed RF should be disregarded.

## APPENDIX E (CONT'D)

TEST SET-UP  
DIAGRAM: (cont'd)

EXAMPLES:

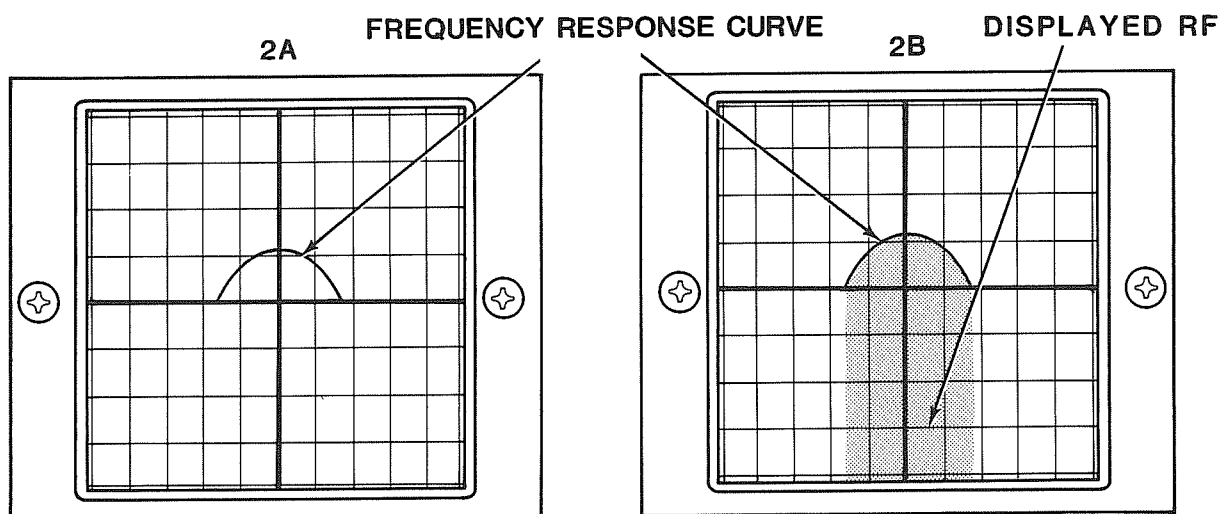

TYPICAL FREQUENCY RESPONSE  
CURVE AFTER REDUCING  
FREQUENCY DEVIATION (USING  
POSITIVE DETECTOR AND  
NARROWER FREQUENCY SPAN)

TYPICAL FREQUENCY RESPONSE  
CURVE AFTER REDUCING FREQUENCY  
DEVIATION (NARROWER FREQUENCY  
SPAN) AS VIEWED DIRECTLY ON  
OSCILLOSCOPE

FIGURE E-3 FREQUENCY RESPONSE CURVE COMPARISON (AS VIEWED ON  
OSCILLOSCOPE WITH AND WITHOUT USE OF DETECTOR)

Note similarities between examples 2A & 2B above. When viewing frequency response curve directly on oscilloscope (w/o detector), operator should locate legs of frequency response curve and points at which they intersect major horizontal axis.





## APPENDIX F: PINOUT/CONTACT ASSIGNMENTS FOR EXTERNAL ACCESSORY & EXTERNAL MODULATION CONNECTORS

### F-1 PINOUT TABLE FOR EXTERNAL ACCESSORY CONNECTOR

The table below provides pin assignments for the EXT ACC Connector (20) located on front panel of the FM/AM-1000S. This connector provides power and signal sources for external accessory equipment used with the FM/AM-1000S.

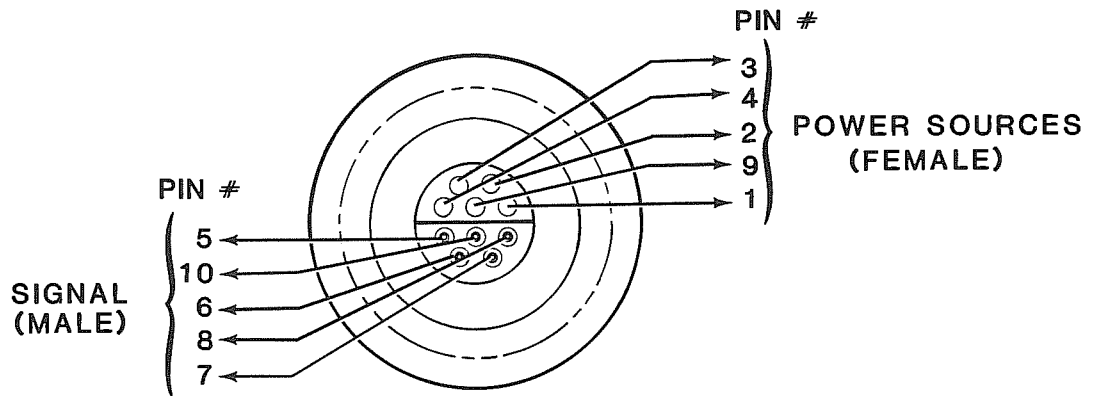

FIGURE F-1 PINOUTS FOR EXTERNAL ACCESSORY CONNECTOR (FRONT VIEW)

CONNECTOR PIN ASSIGNMENTS			
Pin No.	Power Source	Pin No.	Signals
1	+12 V	5	External Modulation
2	+11 V	6	Tone Keying*
3	+5 V	7	Generator Keying**
4	-12 V	8	Demodulated Signal Out
9	Ground	10	Signal Ground

- \* Open enables variable tone generator; short to ground disables variable tone generator.
- \*\* Short to ground places FM/AM-1000S into generate mode.

## APPENDIX F (CONT'D)

### F-2 CONTACT ASSIGNMENTS FOR EXTERNAL MODULATION CONNECTOR

The illustration below provides contact assignments for the mating EXT MOD Connector (3 conductor  $\frac{1}{4}$ " phone plug) used with the EXT MOD Connector (21) on front panel of FM/AM-1000S. This connector provides an external modulation input signal and keying for the FM/AM-1000S Variable Tone generator. (See External Modulation Specifications in Appendix A.)

#### NOTE

- Keying affects only the variable tone generator (not the 1 kHz fixed tone generator or external modulation input.)

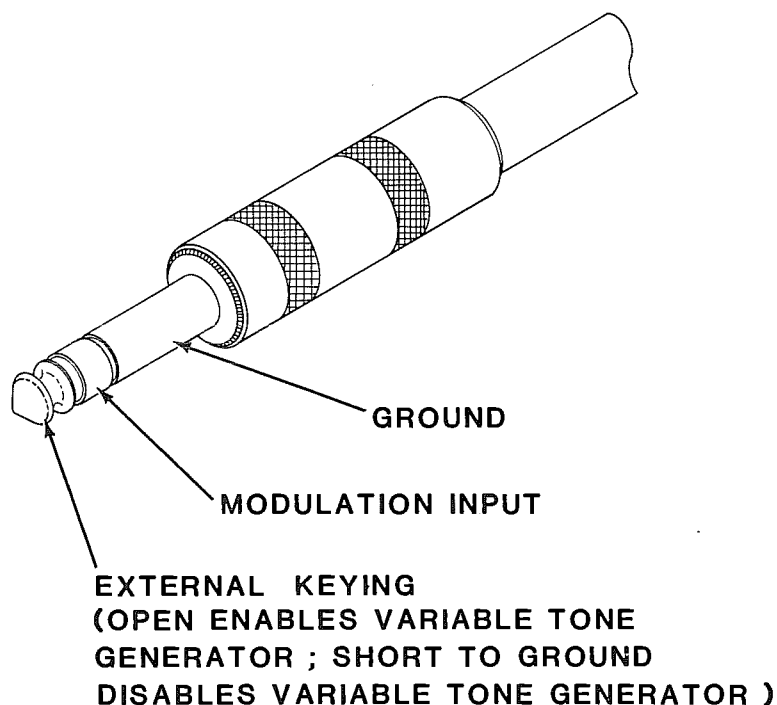

FIGURE F-2 CONTACT ASSIGNMENTS FOR EXTERNAL MODULATION CONNECTOR

## APPENDIX G: HOW TO CONSTRUCT AN RF PICKUP ("SNIFFER") CABLE

Described below are instructions for constructing an RF pickup cable (or "sniffer" cable), which is a required test accessory for operating procedure 4-8-2, titled "OSCILLATOR FREQUENCY MEASUREMENT", on page 4-109.

### MATERIALS REQUIRED:

- 3' (Minimum) length of RG316/U or RG58/U coax cable w/BNC female connector on one end.
- Electrical Tape
- Knife
- Wire Strippers
- Scissors
- Soldering Iron
- Solder

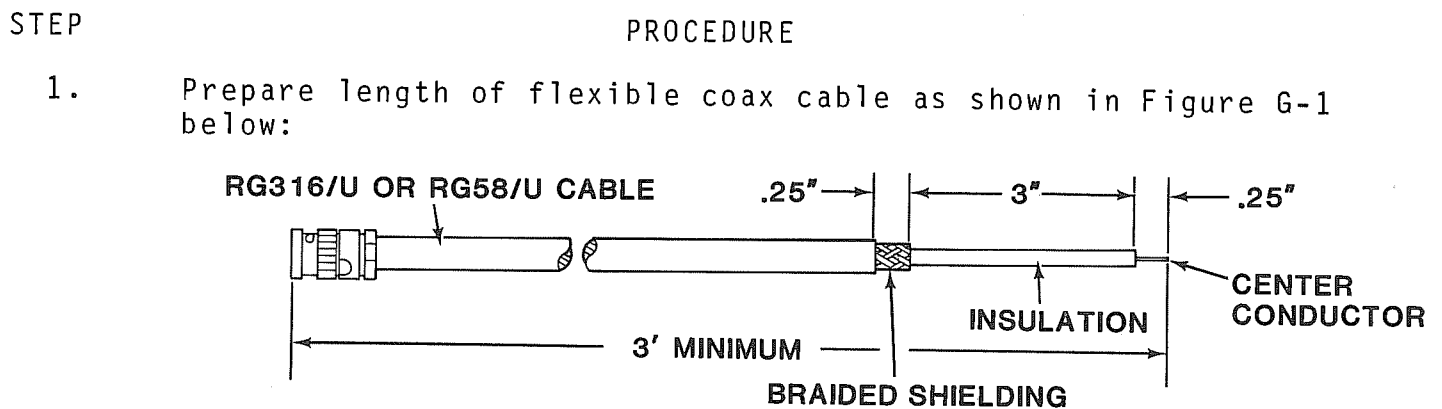

FIGURE G-1 FLEXIBLE COAX CABLE PREPARATION

2. Bend coax cable into loop as shown in Figure G-2 below and solder center conductor to braided shielding.

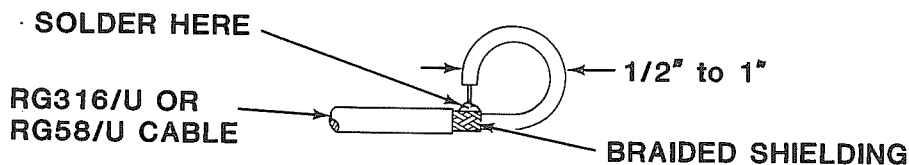

FIGURE G-2 SOLDERING CABLE CENTER CONDUCTOR TO BRAIDED SHIELDING

3. Wrap soldered joint completely with electrical tape, making sure no portion of braided shielding, solder or center conductor is exposed. RF pickup cable is now ready for use.



## APPENDIX H: ABBREVIATIONS & SYMBOLS

Defined below are abbreviations and symbols commonly used throughout the FM/AM-1000S Operation Manual text:

A	- Ampere
AC	- Alternating Current
AM	- Amplitude Modulation
amp hr	- ampere hour
BATT	- Battery
BFO	- Beat Frequency Oscillator
BNC	- Bayonet-Coupled Quick Disconnect (Industry standard coax connector)
°C	- Degrees Celsius
CAL	- Calibrated
ccw	- counterclockwise
cm	- centimeter
cw	- clockwise
CRT	- Cathode Ray Tube
CUT	- Circuit Under Test
dB	- decibels
dBm	- decibels per 1 milliwatt
DC	- Direct Current
EXT ACC	- External Accessory
EXT MOD	- External Modulation
EXT V/DIV	- External Volts per Division
°F	- Degrees Fahrenheit
FM	- Frequency Modulation
GEN	- Generator
HI LVL	- High Level
HORIZ	- Horizontal
Hz	- Hertz
IC	- Integrated Circuit
IF	- Intermediate Frequency
INT MOD	- Internal Modulation
Kg	- Kilogram
kHz	- kilohertz
lbs	- pounds
min	- minute(s)
MHz	- Megahertz
μs	- microsecond
μV	- microvolt
ms	- millisecond
msec	- millisecond
mV	- millivolt
mW	- milliwatt
N/A	- Not Applicable
No.	- Number
NORM	- Normal
PLL	- Phase-Locked Loop

## APPENDIX H (CONT'D)

PPM	- Pulse Per Minute
psi	- pounds per square inch
PWR	- Power
RCVR	- Receiver
RF	- Radio Frequency
RFi	- Radio Frequency Interference
RMS	- Root Mean Square
scope	- oscilloscope
sec	- second(s)
SIG	- Signal
SINAD	- Signal plus Noise and Distortion
TCXO	- Temperature Compensated Crystal Oscillator
TRANS	- Transmitter
typ.	- typical
UUT	- Unit Under Test
V	- Volts
Vp	- Volts Peak
Vp-p	- Volts Peak-to-Peak
Vv	- Volts Valley
VAC	- Volts Alternating Current
VDC	- Volts Direct Current
VOL	- Volume
V RMS	- Volts Root Mean Square
W	- Watts

### **MM-100**

- Designation for test procedures which can be more easily performed using MM-100 Multi-Meter option, if FM/AM-1000S is so equipped.











Precision Simulators

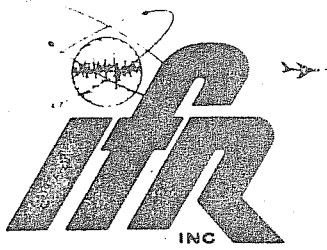

**FM/AM 1000S**  
**Communications Service Monitor**

DATA PACKAGE  
Schematics - Printed Circuit Boards

PUBLISHED BY  
IFR, INC.  
Wichita, Kansas

Copyright 1981 by IFR, Inc.

All rights reserved. Printed in the United States of America. No part of this publication may be reproduced, stored in a retrieval system or transmitted in any form or by any means, electronic, mechanical, photocopying, recording or otherwise, without the prior permission of the publisher.

Manual Part Number: 1007-5000-100

NOTE

All schematics and print circuit boards apply to FM/AM-1000S regardless of indicated serialization or model number designation.

## TABLE OF CONTENTS

Item	Figure No.
Inter Connect . . . . .	1
Regulator and Power Supply Schematic . . . . .	2
Regulator and Power Supply Board . . . . .	3
Duty Cycle Regulator and Battery Charger Schematic . . . . .	4
Static Discharge Protector . . . . .	5
1200 MHz Filter and Receive/Generate Switch . . . . .	6
1200 MHz Amplifier . . . . .	7
1200 MHz Amplifier PC Board Assy . . . . .	8
Second Mixer - Diode Switch Schematic . . . . .	9
1080 MHz Multiplier Amplifier . . . . .	10
1080 MHz Multiplier Amplifier PC Board Assy . . . . .	11
108 MHz Filter Schematic . . . . .	12
79-80 MHz Loop Schematic . . . . .	13
100 MHz Multiplier and 108 MHz Mixer . . . . .	14
100 MHz Multiplier and 108 MHz Mixer PC Board Assy . . . . .	15
100 MHz Filter Schematic . . . . .	16
100 MHz Filter PC Board Assy . . . . .	17
Hi-Freq Multi/Mixer Schematic . . . . .	18
Het Amp ÷ 2 Prescaler . . . . .	19
Het Amp ÷ 2 Prescaler PC Assy . . . . .	20
High Freq Phase Lock CKT . . . . .	21
High Frequency Phase Lock PC Board Assy . . . . .	22
VCO Tuner . . . . .	23
VCO Tuner PC Board Assy . . . . .	24
Clock Divider . . . . .	25
Clock Divider PC Board Assy . . . . .	26
120 MHz Receiver, 250 kHz Output . . . . .	27
120 MHz Receiver PC Board Assy . . . . .	28
250 kHz IF-Mon-Audio Board Schematic . . . . .	29
250 kHz IF-Mon-Audio Board Assy . . . . .	30
1200-2200 MHz Oscillator, Buffer, Tune Summation . . . . .	31
1200-2200 MHz Oscillator PC Board Assy . . . . .	32
AGC System Schematic . . . . .	33
AGC System PC Board Assy . . . . .	34
Scope Interconnect . . . . .	35
Scope Schematic . . . . .	36
Scope Main Board Assy Drawing . . . . .	37
Spectrum Analyzer Interconnect . . . . .	38
Spectrum Analyzer Test Interconnect . . . . .	39
Inverter Board Schematic for the Spectrum Analyzer . . . . .	40
Spectrum Analyzer Inverter PC Board Assy . . . . .	41
Spectrum Analyzer Board No. 1 Schematic . . . . .	42
Spectrum Analyzer Board No. 2 Schematic . . . . .	43

Spectrum Analyzer PC Board Assy Board No. 1 . . . . .	44
Spectrum Analyzer Board No. 2 Assy . . . . .	45
TCXO Output Distribution Schematic . . . . .	46
TCXO Output Dist Amp Assy . . . . .	47
Change Notice 1, Duty Cycle Regulator . . . . .	48
Change Notice 2, Rear Panel . . . . .	49
FM/AM Gen Schematic Wide Dev FM . . . . .	50
FM/AM Generator PC Board Assy . . . . .	51
Dual Tone Generator Circuit Schematic . . . . .	52
Dual Tone Generator Board No. 1 Assy . . . . .	53
Dual Tone Generator Board No. 2 Assy . . . . .	54
Dual Tone Generator PC Board No. 3 Assy . . . . .	55
First Mixer and Switch Circuit Schematic . . . . .	56
Power Monitor Assy Circuit Schematic . . . . .	57
XMTR Sensor Assy Circuit Schematic . . . . .	58
Relay Driver Circuit Schematic . . . . .	59
Relay Driver PC Board Assy . . . . .	60
High Level Amp Circuit Schematic . . . . .	61
High Level Amp PC Board No. 1 Assy . . . . .	62
High Level Amp PC Board No. 2 Assy . . . . .	63









DATE	REV	CHANGE	APP
2/17/75	A	INCORPORATED ECN # 200	MD
2/17/75	B	INCORPORATED ECN # 317	MD
2/17/75	C	INCORPORATED ECN # 336	MD
2/17/75	D	INCORPORATED ECN # 419	GLD
2/17/75	E	INCORPORATED ECN # 592	JNW
2/14/75	F	INC ECN # 571 & 677	WJ
2/17/75	G	INC ECN # 743	JUN WLP
2/17/75	H	INC ECN # 799	WJ
11/18/74	J	INC ECN # 1116, 1135	WJ
2-9-74	K	INCORP. ECN # 1290, 1313	WJ
6-11-74	L	INCORP. ECN # 1464	WJ
6-16-74	M	INCORPORATED ECN # 1620	JUN
1/7/74	N	INCORP. ECN # 1674	JUN WLP
1/4/77	P	INC ECN # 1842	RKK
1/14/77	R	INC ECN # 2163 & 2204	LC
1-28-75	S	INC ECN # 2850	WJ

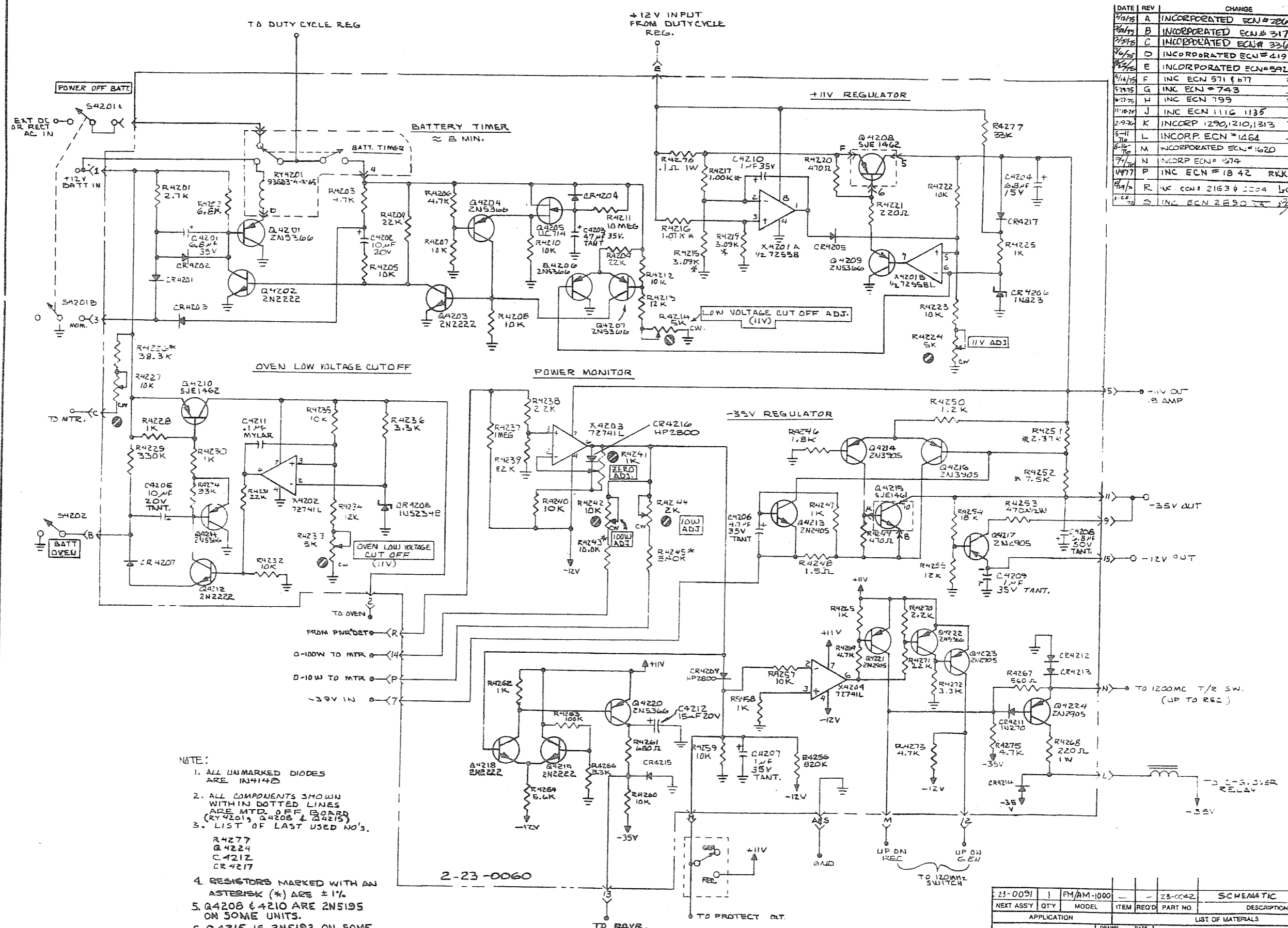

- NOTE:
1. ALL UNMARKED DIODES ARE IN4148
  2. ALL COMPONENTS SHOWN WITHIN DOTTED LINES ARE MTD. OFF BOARD (RY4201, Q4208 & Q4215)
  3. LIST OF LAST USED NO'S.  
R4277  
Q4224  
C4212  
CR4217
  4. RESISTORS MARKED WITH AN ASTERISK (\*) ARE ±1%
  5. Q4208 & Q4210 ARE 2N5195 ON SOME UNITS.
  6. Q4215 IS 2N5192 ON SOME UNITS.
  7. Q4202, Q4203, Q4212, Q4218, & Q4219 ARE 2N3415 ON SOME UNITS.

2-23-0060  
ARTWORK  
1-23-0091  
PARTS LIST

23-0091	1	FM/AM-1000		23-0042	SCHEMATIC
NEXT ASSY	QTY	MODEL	ITEM	RECD	PART NO
APPLICATION					
LIST OF MATERIALS					
TOLERANCES			DRAWN DATE		
UNLESS OTHERWISE SPECIFIED			LD 2-5-74		
ALL DIMENSIONS APPLY AFTER FINISH			CHECKED DATE		
DECIMALS: 1/16 - 3/16 .001 - .002			4-5 2-17-74		
FRACTIONS: 1/8 - 1/2			APPROVED DATE		
SURFACE FINISHES			MD 2-13-75		
REMOVE ALL BURRS					
INSTRUMENT FLIGHT RESEARCH CORPORATION WICHITA, KANSAS					
TITLE REGULATOR & POWER SUPPLY SCHEMATIC (FM-AM-1000)					
MATERIAL		SIZE		REV	
TREATMENT		PART NUMBER		3-23-0042	
FINISH		SCALE		SHEET 1 OF 1	

NOTES:

1. ALL RESISTORS ARE 1/4 W., 10% TOLERANCE EXCEPT AS NOTED.
2. ALL CAPACITOR VALUES ARE IN  $\mu F$  EXCEPT AS NOTED.
3. COMPONENT LEADS MAY EXTEND .04 TO .06 BEYOND BOTTOM OF BOARD AFTER SOLDERING.
4. MAXIMUM HEIGHT OF COMPONENTS TO BE .36 FROM COMPONENT SIDE OF BOARD.
- 5.
6. \*NOTES 1% 1/4W RES.
7. R56 IS MTD ON BACK SIDE AS SHOWN IN BOTTOM VIEW ONLY ON "E" REV. ARTWORK. FOR "F" REV IT WILL LOCATE AS IN THE LARGER VIEWS.

DATE	REV	CHARGE	APP'D
11/27/51	R	ORIG REL	[Signature]
12/5/51	S	INC. CON. 2890751	[Signature]

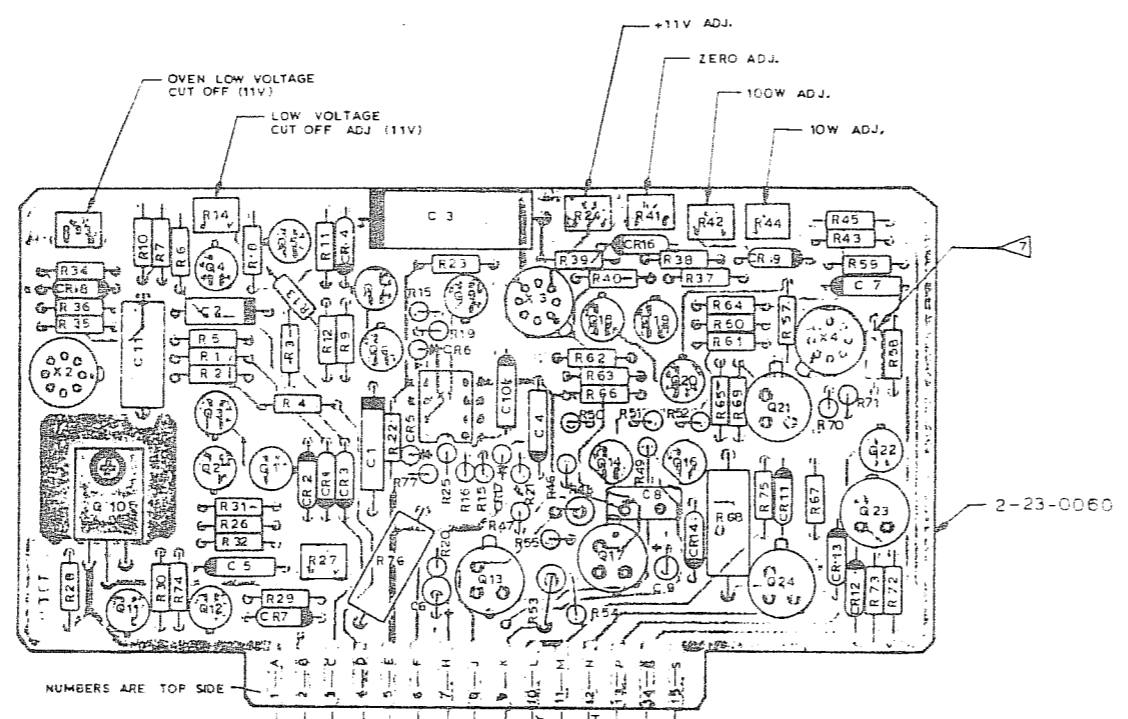

- NUMBERS ARE TOP SIDE
- 1. 12V BATTERY IN
  - 2. TO OVEN
  - 3. BATTERY OVEN
  - 4. MONITOR
  - 5. TO BATT. TIMER RELAY
  - 6. TO BATT. RELAY
  - 7. TO BATT. RELAY
  - 8. TO BATT. RELAY
  - 9. TO BATT. RELAY
  - 10. TO BATT. RELAY
  - 11. TO BATT. RELAY
  - 12. TO BATT. RELAY
  - 13. TO BATT. RELAY
  - 14. TO BATT. RELAY
  - 15. TO BATT. RELAY
  - 16. TO BATT. RELAY
  - 17. TO BATT. RELAY
  - 18. TO BATT. RELAY
  - 19. TO BATT. RELAY
  - 20. TO BATT. RELAY
  - 21. TO BATT. RELAY
  - 22. TO BATT. RELAY
  - 23. TO BATT. RELAY
  - 24. TO BATT. RELAY
  - 25. TO BATT. RELAY
  - 26. TO BATT. RELAY
  - 27. TO BATT. RELAY
  - 28. TO BATT. RELAY
  - 29. TO BATT. RELAY
  - 30. TO BATT. RELAY
  - 31. TO BATT. RELAY
  - 32. TO BATT. RELAY
  - 33. TO BATT. RELAY
  - 34. TO BATT. RELAY
  - 35. TO BATT. RELAY
  - 36. TO BATT. RELAY
  - 37. TO BATT. RELAY
  - 38. TO BATT. RELAY
  - 39. TO BATT. RELAY
  - 40. TO BATT. RELAY
  - 41. TO BATT. RELAY
  - 42. TO BATT. RELAY
  - 43. TO BATT. RELAY
  - 44. TO BATT. RELAY
  - 45. TO BATT. RELAY
  - 46. TO BATT. RELAY
  - 47. TO BATT. RELAY
  - 48. TO BATT. RELAY
  - 49. TO BATT. RELAY
  - 50. TO BATT. RELAY
  - 51. TO BATT. RELAY
  - 52. TO BATT. RELAY
  - 53. TO BATT. RELAY
  - 54. TO BATT. RELAY
  - 55. TO BATT. RELAY

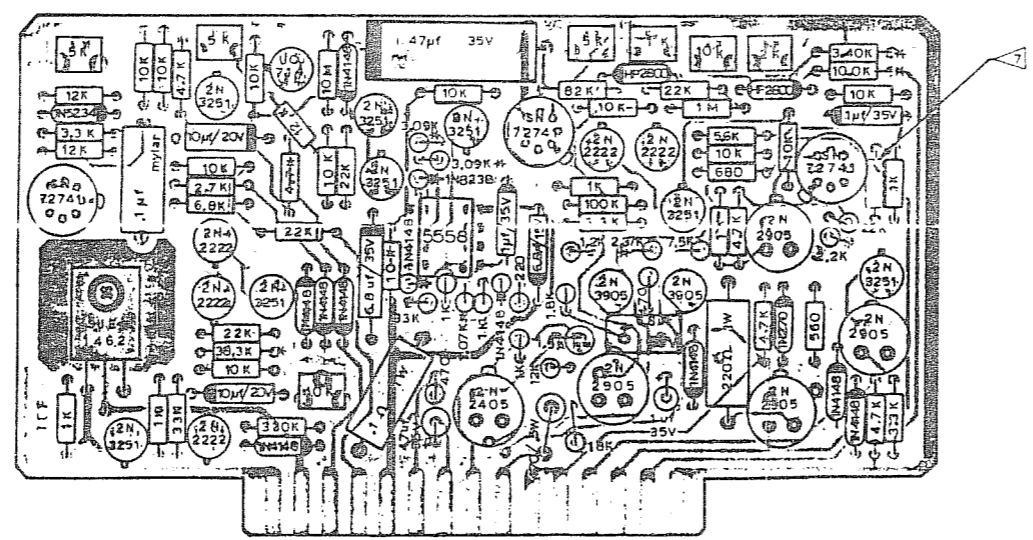
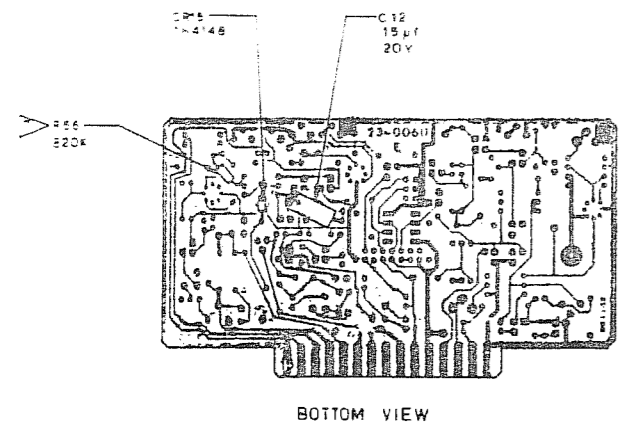

PART LIST No. 1-23-0091  
SCHEMATIC No. 3-23-0042

ITEM REQ'D		PART NO.	DESCRIPTION
LIST OF MATERIALS			
- IFR INC - WICHITA, KANSAS -			
REGULATOR & POWER SUPPLY BOARD (FM AM 1000/A)			
DATE		4-23-0091	
SCALE		2X1	
SHEET		1 OF 1	

DATE	REV	CHANGE	BY
11/27/74	A	INC. ECN # 063	LD
11/27/74	B	INCORPORATED ECN # 239	SSD
11/27/74	C	INCORPORATED ECN # 536 & # 567	JW
11/27/74	D	INCORPORATED ECN # 751	JW
11/27/74	E	INCORP ECN # 1377	JW
11/27/74	F	INCORP ECN # 1394	JW
11/27/74	G	INCORP ECN # 2153	AA
11/27/74	H	INC. ECN # 2482 & 2505 & 2529	LC
11/27/74	J	INC. ECN # 2698	ST

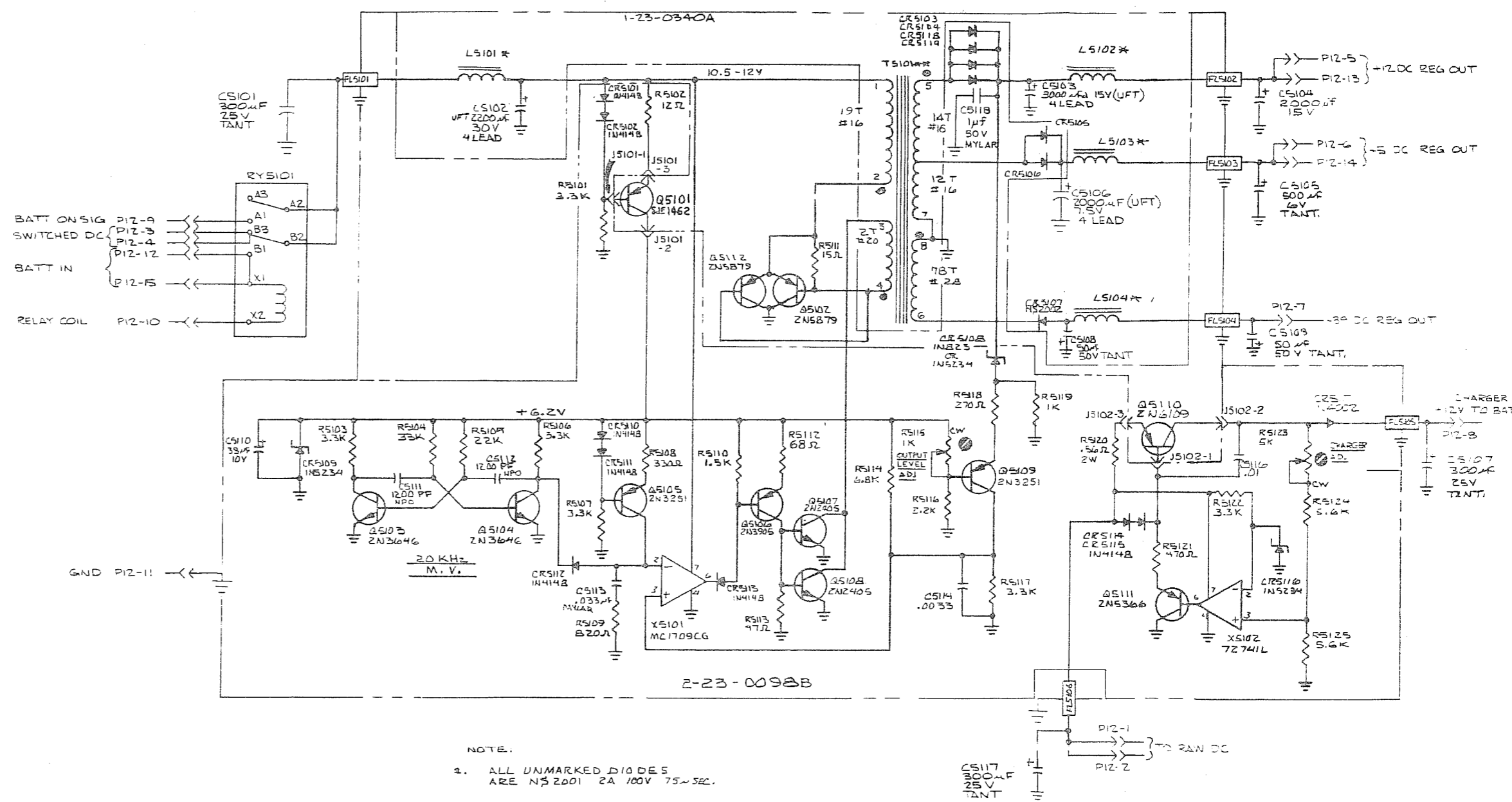

- NOTE:
1. ALL UNMARKED DIODES ARE N32001 2A 100V 75-SEC.
  2. \* L5101, 2, 3, 4 ARE 28T #17 WIRE ON MAGNETICS CORE 55930-AZ
  3. \*\* T5101 IS ON MAGNETICS CORE 55548-AZ

23-0090	1	PM/AM 1000	1	1	23-MS1	SCHEMATIC
NEXT ASSY	QTY	MODEL	ITEM	REQ'D	PART NO.	DESCRIPTION
APPLICATION						
LIST OF MATERIALS						
TOLERANCES UNLESS OTHERWISE SPECIFIED			DRAWN DATE			
ALL DIMENSIONS APPLY AFTER FINISH			2-15-74			
DECIMALS: .01 - .010 XXX - .005			CHECKED DATE			
ANGLES: 1/16			2-15-74			
FRACTIONS: 1/32			APPROVED DATE			
SURFACE ROUGHNESS REMOVE ALL BURRS			MS 6475			
MATERIAL		FINISH	SCALE	WEIGHT	REVISION	REVISION
		C	3-23-0051			
						SHEET 1 OF 2

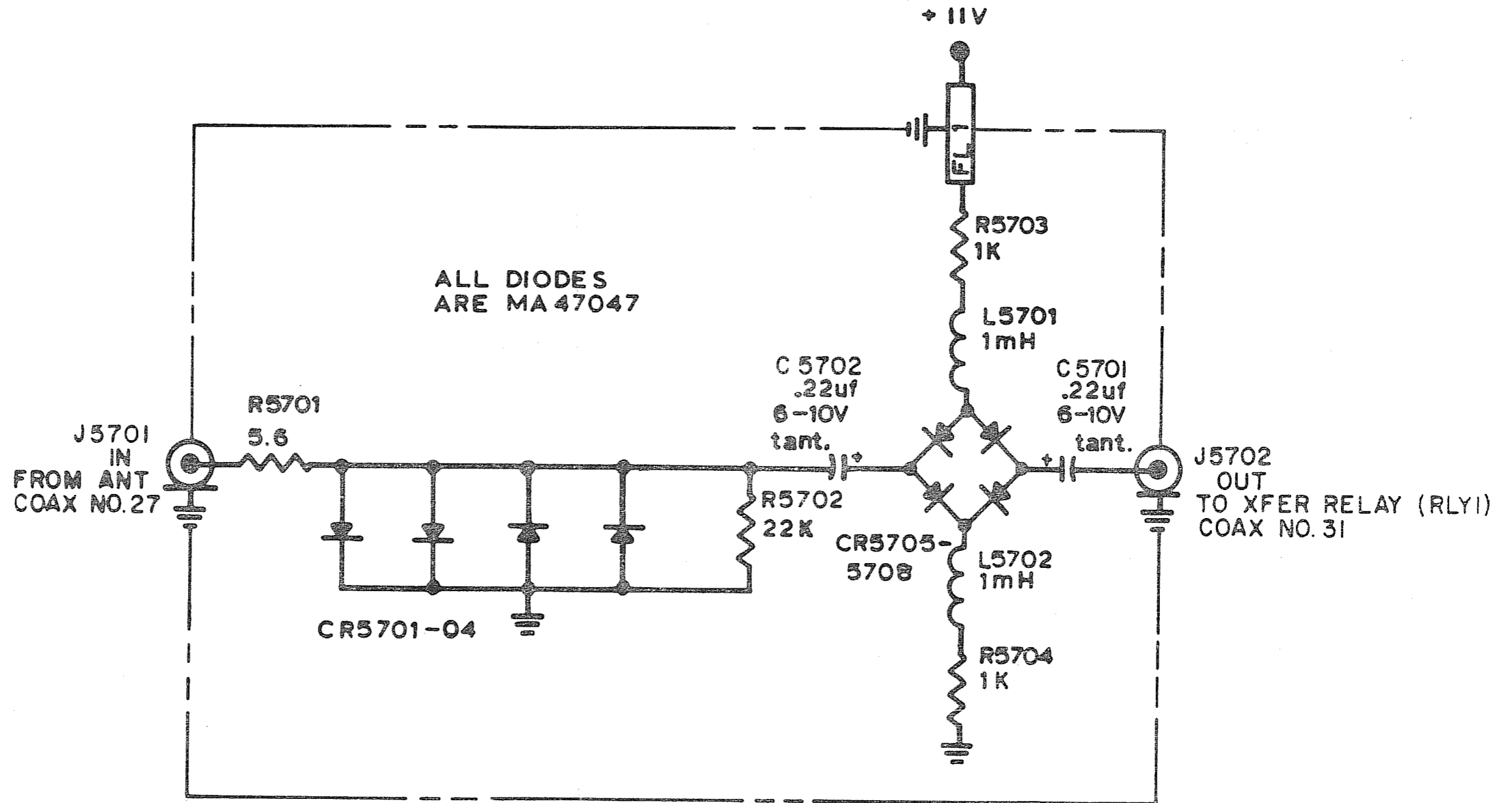

DATE	REV	CHANGE	APP'D
1/5/78	B	IN CORP ECN #2678 AA	W W
6-1-76	A	IN CORP ECN #1475 RKK	W

INSTRUMENT FLIGHT RESEARCH CORP. 4053 Navajo Lane Wichita, Ks.		DWN DATE 8 10-15-75
STATIC DISCHARGE PROTECTOR (FM-1000)		CHKD DATE 9/5-10-15-75
PART NO 1-23-0457		APP DATE 9/8 10-17-75
SCALE ~	REV B DATE 1/5/78	DWN RKK APP MLO
MODEL FM-1000	SHT. 1 of 1	

DATE	REV	CHANGE	APP'D
723	A	INC ECN # 1 LD	
7175	B	INC ECN # 802 MW DLP	MW
11/27/78	C	INC ECN # 2914 JT	WW

TO 1200 MHz AMP.  
INPUT  
J12402 COAX 17

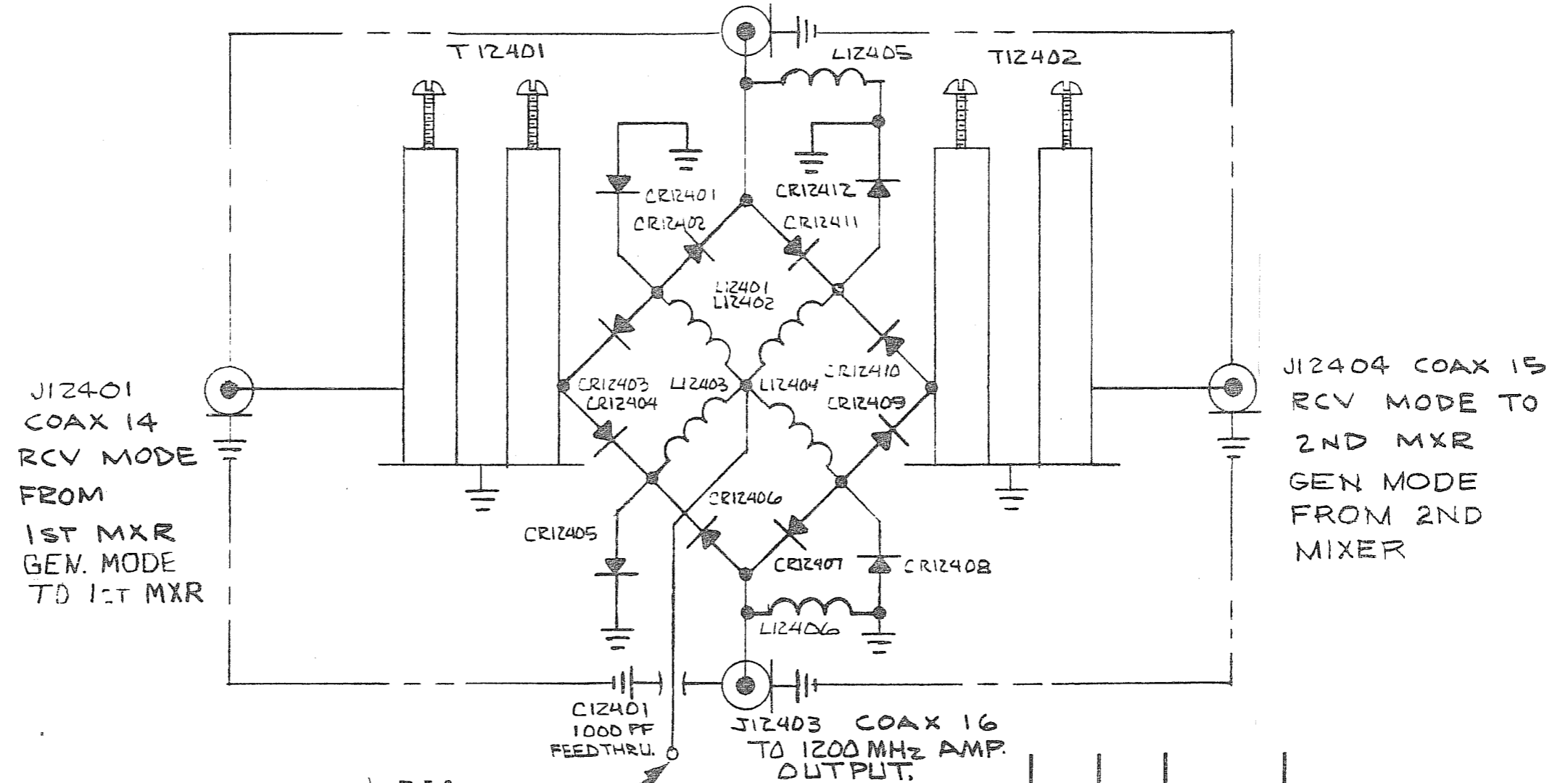

NOTE:  
1. ALL DIODES ARE MA47047  
2. ALL CHOKE COILS ARE .33 μH

+ REC.  
- GEN.

23-0297	1	FM/AM 1000			23-0124	SCHEMATIC
NEXT ASS'Y	QTY	MODEL	ITEM	REQ'D	PART NO.	DESCRIPTION
APPLICATION			LIST OF MATERIALS			
<b>TOLERANCES</b> UNLESS OTHERWISE SPECIFIED ALL DIMENSIONS APPLY AFTER FINISH DECIMALS: .xx = ± .010 .xxx = ± .005 ANGLES: ± 1/2° FRACTIONS: ± 1/64 SURFACE ROUGHNESS 125 REMOVE ALL BURRS			DRAWN <i>[Signature]</i> 4-5-74 CHECKED a.s. 8-6-74 APPROVED MW 7-17-78	<b>INSTRUMENT FLIGHT RESEARCH CORPORATION</b> WICHITA, KANSAS. TITLE 1200MHz FILTER & REC.-GEN. SW.		
MATERIAL	SIZE		PART NUMBER		REV	
TREATMENT	A		1-23-0124		C	
FINISH	SCALE	WEIGHT		SHEET 1 OF 1		



DATE	REV	CHANGE	APP'D
1-7-78	A	INC ECN 2682 JAT	WU
1-16-77	A-1	INC ECN 2709 JAT	WU

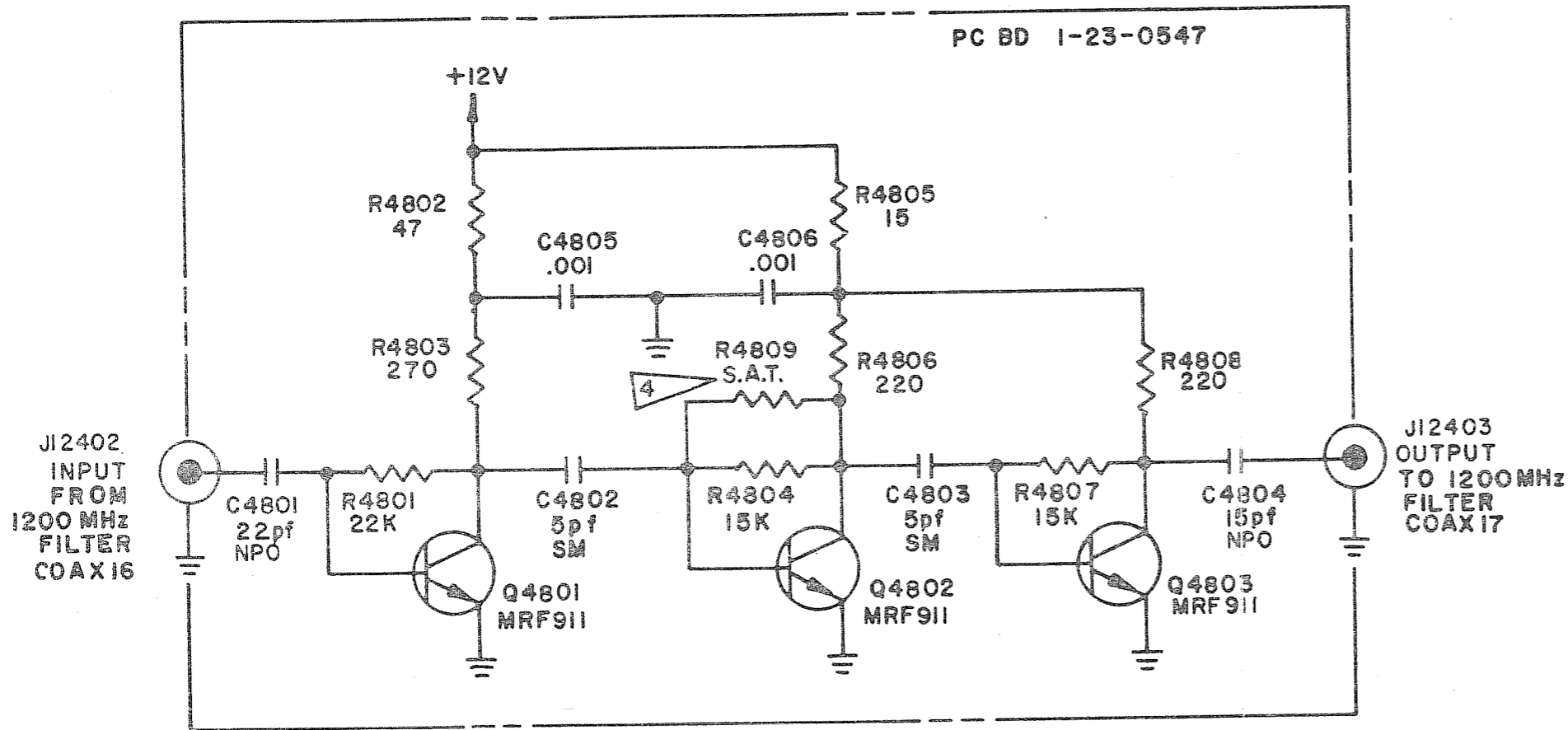

NOTES:

1. ALL RESISTORS ARE IN 1/4 W, 10%, AND VALUES ARE IN OHMS UNLESS OTHERWISE SPECIFIED.
2. ALL CAPACITORS ARE IN MICROFARADS UNLESS OTHERWISE SPECIFIED.
3. LAST NUMBERS USED: R4809, C4806, Q4803

4 SELECT AT TEST TO REDUCE GAIN

ITEM	REQ'D	PART NO.	DESCRIPTION
1	1	23-0548	SCHEMATIC

LIST OF MATERIALS

DRAWN 5-5-76	DATE	- IFR INC - WICHITA, KANSAS	
	CHECKED 2/5-5-76	DATE	TITLE 1200MHz AMPLIFIER
APPROVED M 88%	DATE	SIZE B	PART NUMBER 2-23-0548
	DATE	SCALE	WEIGHT
TOLERANCES UNLESS OTHERWISE SPECIFIED ALL DIMENSIONS APPLY AFTER FINISH DECIMALS: .XX = ± .010 .XXX = ± .005 ANGLES: ± 1/2° FRACTIONS: ± 1/64 SURFACE ROUGHNESS REMOVE ALL BURRS		FINISH	SHEET 1 OF 1

DATE	REV	CHANGE	APP'D
12/1/51	A	INITIAL RELEASE	M

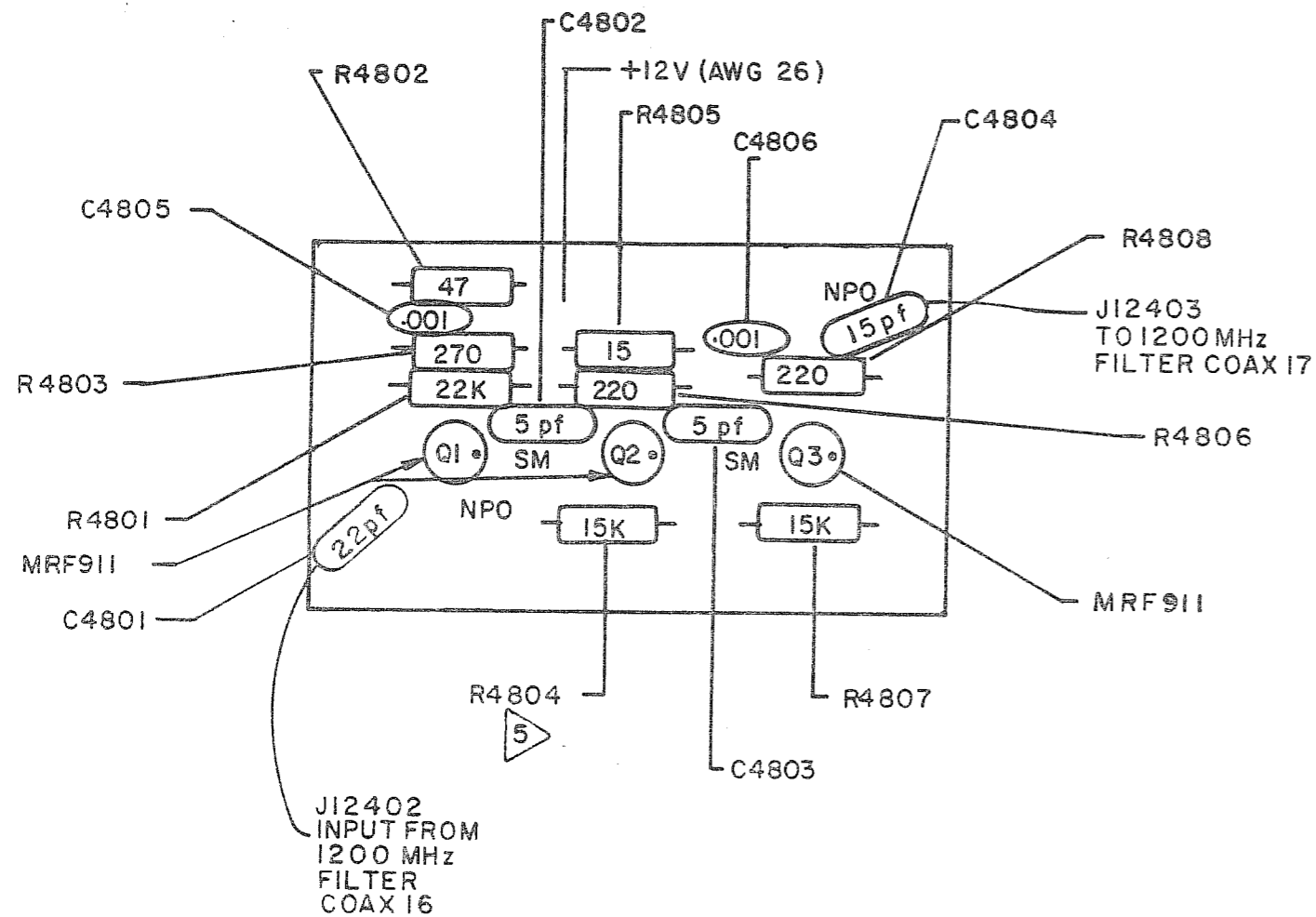

5 R4809 SAT PARALLELS R4804 AS REQ'D

- MAXIMUM HEIGHT OF COMPONENTS FROM COMPONENT SIDE OF BOARD IS .35.
- COMPONENT LEADS MAY EXTEND .04-.06 BEYOND BOTTOM OF BOARD AFTER SOLDERING

2. UNLESS OTHERWISE SPECIFIED:

ALL CAPACITORS ARE IN  $\mu$ F

ALL RESISTORS ARE 1/4W  $\pm$ 10%

1. REF DWG :

PC BOARD 1-23-0547

SCHEMATIC 2-23-0548

NOTES:

23-0554	1	FM/AM1000S					
23-0554	1	FM/AM1000A	1	1	23-0549	ASSY	P/L
NEXT ASS'Y	QTY	MODEL	ITEM	REQ'D	PART NO.	DESCRIPTION	
APPLICATION				LIST OF MATERIALS			
TOLERANCES UNLESS OTHERWISE SPECIFIED			DRAWN DATE 1/11/57		INSTRUMENT FLIGHT RESEARCH CORPORATION WICHITA, KANSAS		
ALL DIMENSIONS APPLY AFTER FINISH			CHECKED DATE 1/11/57		TITLE 1200 Mhz AMPLIFIER PC BD ASSY		
DECIMALS: $\pm$ .005			APPROVED DATE 1/11/57				
ANGLES: $\pm$ 1/2°							
FRACTIONS: $\pm$ 1/64							
SURFACE ROUGHNESS REMOVE ALL BURRS							
MATERIAL				SIZE B		PART NUMBER 2-23-0549	
TREATMENT				SCALE		WEIGHT	
FINISH						SHEET 1 OF 1	

DATE	REV	CHANGE	APP'D
2-4-76	A	INCORP ECN #1271	SSD
12-7-77	B	INC ECN #2581 JAT	ML
5-23-78	C	INC ECN 2709 JAT	ML
5-9-78	D	INC ECN 2722 JAT	WJ

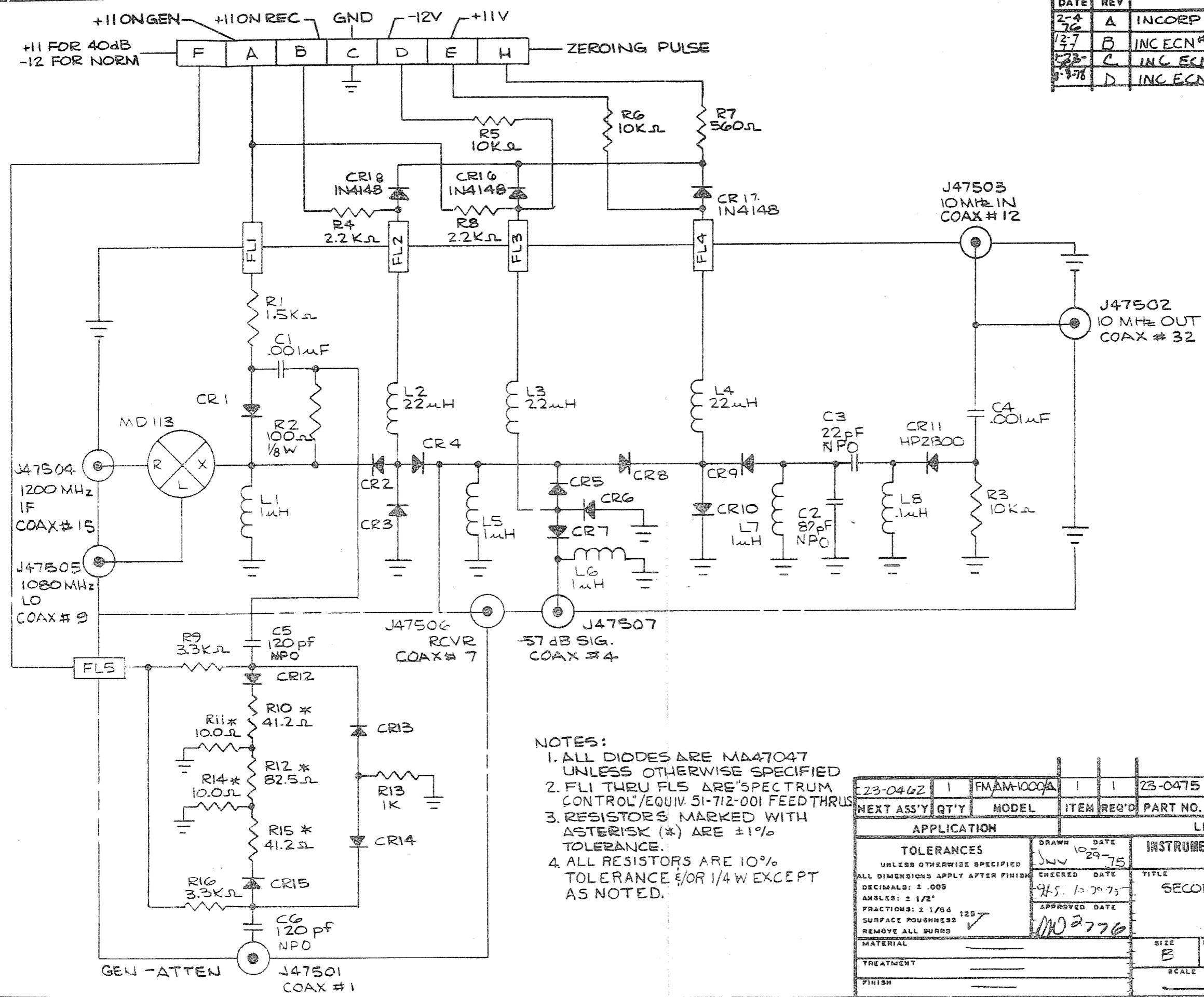

- NOTES:
1. ALL DIODES ARE MA47047 UNLESS OTHERWISE SPECIFIED
  2. FL1 THRU FL5 ARE "SPECTRUM CONTROL"/EQUIV 51-712-001 FEEDTHRU
  3. RESISTORS MARKED WITH ASTERISK (\*) ARE ±1% TOLERANCE.
  4. ALL RESISTORS ARE 10% TOLERANCE &/OR 1/4 W EXCEPT AS NOTED.

23-0462	1	FM/AM-1000A	1	1	23-0475	SCHEMATIC
NEXT ASS'Y	QTY	MODEL	ITEM	REQ'D	PART NO.	DESCRIPTION
APPLICATION			LIST OF MATERIALS			
TOLERANCES UNLESS OTHERWISE SPECIFIED			DRAWN DATE		INSTRUMENT FLIGHT RESEARCH CORPORATION WICHITA, KANSAS	
ALL DIMENSIONS APPLY AFTER FINISH			JUN 10 29-75		TITLE	
DECIMALS: ± .005			CHECKED DATE		SECOND MIXER-DIODE SWITCH	
ANGLES: ± 1/2°			9/5 10 20 75		SCHEMATIC	
FRACTIONS: ± 1/64			APPROVED DATE		FM/AM-1000/A	
SURFACE ROUGHNESS REMOVE ALL BURRS			MO 2776		SIZE B PART NUMBER 2-23-0475 REV D	
MATERIAL			SCALE		WEIGHT	
TREATMENT			FINISH		SHEET 1 OF 1	

DATE	REV	CHANGE	APP'D
11-18-76	A	ADDED OUTPUT TUNELINE AS W3	ME
12-16-76	B	ADDED INPUT, TUNELINE NOMEN- CLATURE, ECN #1792	WW
11-29-77	C	ECN # 2598	JAJ
1-17-78	D	ECN 2709	

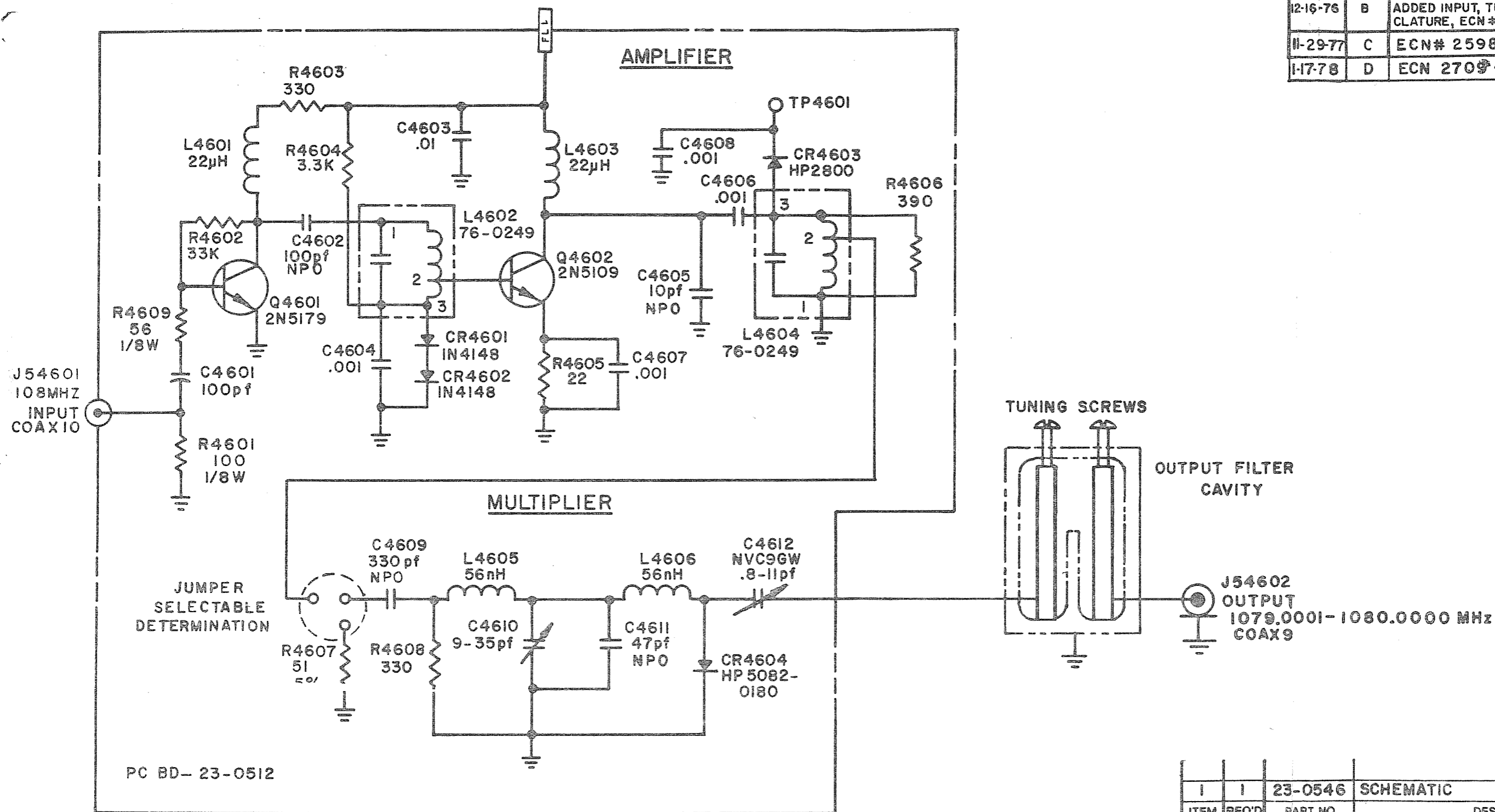

PC BD-23-0512

- NOTES:
1. RESISTORS ARE 1/4 W, 10%, AND VALUES ARE IN OHMS UNLESS OTHERWISE SPECIFIED.
  2. CAPACITORS ARE IN MICROFARADS UNLESS OTHERWISE SPECIFIED.
  3. LAST NUMBERS USED: R4609, C4612, CR4604, L4606, Q4602, TP4601

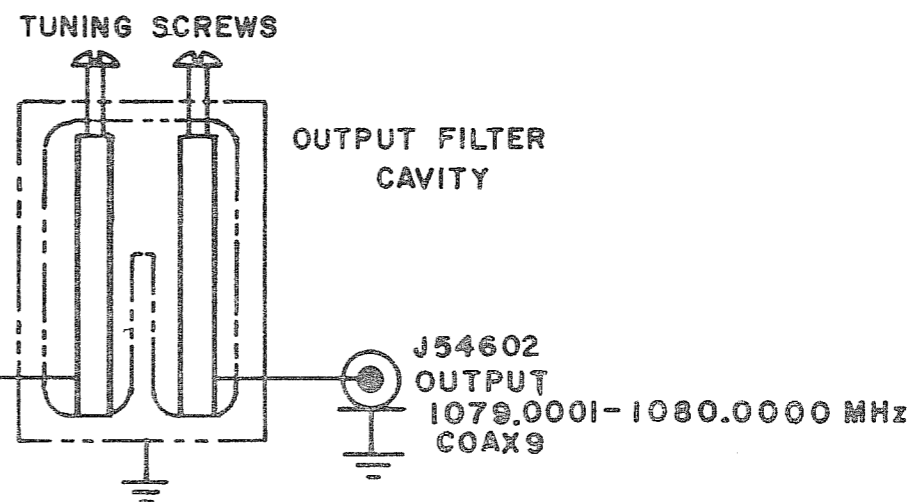

ITEM	REQ'D	PART NO.	DESCRIPTION
1	1	23-0546	SCHEMATIC

APPLICATION		TOLERANCES		DRAWN		TITLE	
23-0513	1	UNLESS OTHERWISE SPECIFIED	ALL DIMENSIONS APPLY AFTER FINISH	350	4-23-76	- IFR INC - WICHITA, KANSAS	
1	1	DECIMALS: .XX = ± .010 .XXX = ± .005	ANGLES: ± 1/2°	25	4-28-76	1080 MHz MULTIPLIER AMPLIFIER	
		FRACTIONS: ± 1/64	SURFACE ROUGHNESS	APPROVED	DATE	SIZE	PART NUMBER
		REMOVE ALL BURRS	125	ME	7-23-76	B	2-23-0546
						SCALE	WEIGHT
							SHEET 1 OF 1

DATE	REV	CHANGE	APP'D
11-9-77	D	ORIGINAL RELEASE TT	
1-15-78	D-1	INC ECN 2709 JAS	W/W
6-28-79	D-2	INC ECN 3050 (9/15/79)	W/W

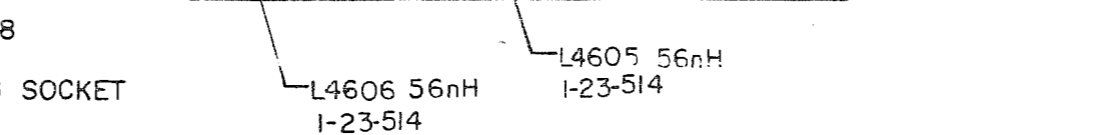
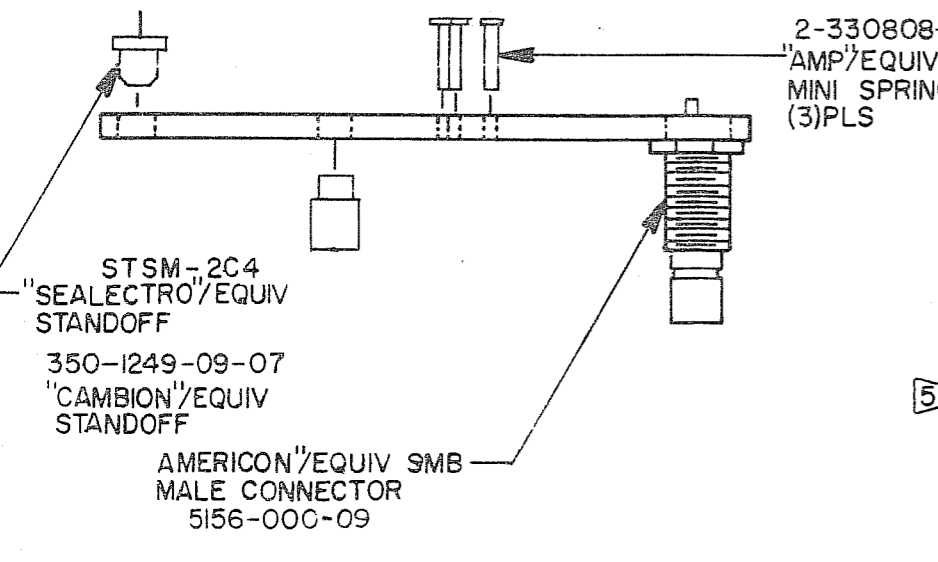
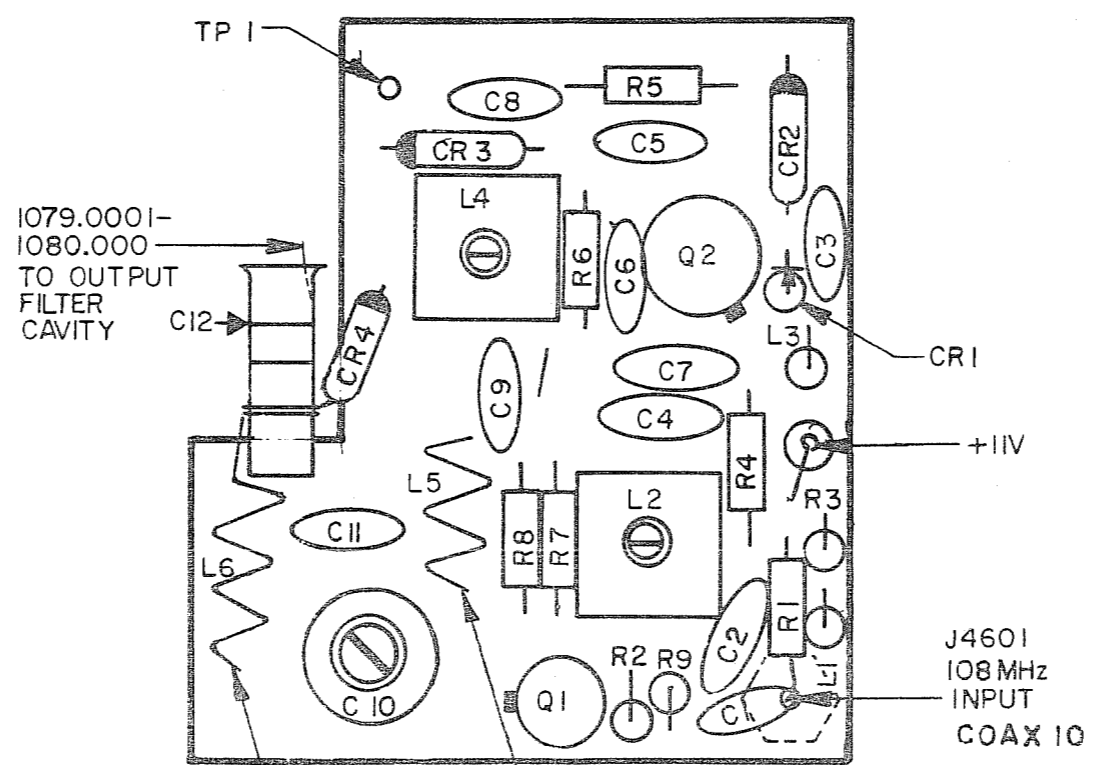
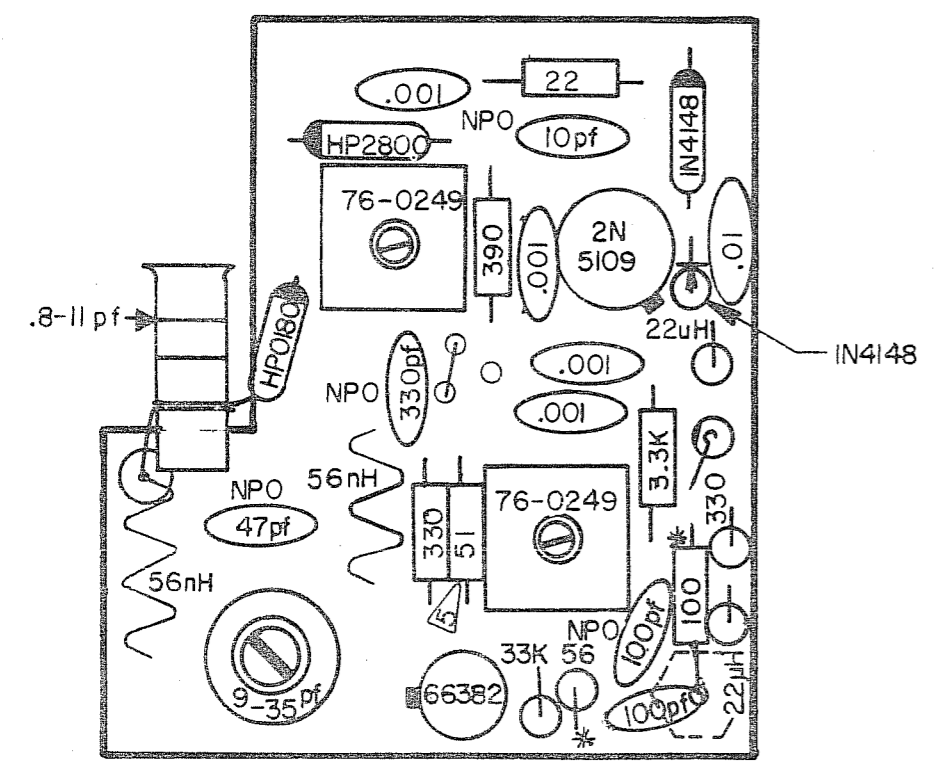

9 PC BOARD NO. 1-23-512  
 8 SCHEMATIC NO. 2-23-546  
 7 COMPONENT DESIGNATORS HAVE 46 PREFIX i.e. R4601, C4601, L4601 etc.

- 6 "\*" DENOTES 1/8W, 10% RES.
  - 5 R7 IS 51 OHM, 1/4W, 5% RES.
  - 4 MAX. HEIGHT OF COMPONENTS TO BE .53 FROM COMPONENT SIDE OF BOARD.
  - 3 COMPONENT LEADS MAY EXTEND .04 TO .06 BEYOND BOTTOM OF BOARD AFTER SOLDERING.
  - 2 ALL CAPACITORS ARE IN  $\mu$ F EXCEPT AS NOTED.
  - 1 ALL RESISTORS ARE 1/4W, 10% TOL. EXCEPT AS NOTED.
- NOTES

23-516	1	FM/AM1000A/S				
NEXT ASS'Y	QT'Y	MODEL	ITEM	REQ'D	PART NO.	DESCRIPTION
APPLICATION			LIST OF MATERIALS			
TOLERANCES UNLESS OTHERWISE SPECIFIED		DRAWN DATE TenEyck 11-9-77		INSTRUMENT FLIGHT RESEARCH CORPORATION WICHITA, KANSAS		
ALL DIMENSIONS APPLY AFTER FINISH		CHECKED DATE		TITLE 1080MHz MULTIPLIER AMPLIFIER PC BOARD ASSEMBLY		
DECIMALS: $\pm$ .005		APPROVED DATE		MATERIAL		
ANGLES: $\pm$ 1/2°				SIZE B		
FRACTIONS: $\pm$ 1/64				PART NUMBER 2-23-513		
SURFACE ROUGHNESS REMOVE ALL BURRS				REVISION D-2		
FINISH				SCALE 2:1		
				WEIGHT		
				SHEET 1 OF 1		

DATE	REV	CHANGE	APP'D
1-17-72	A	INC ELCN 2709 JAS <i>[Signature]</i>	WU

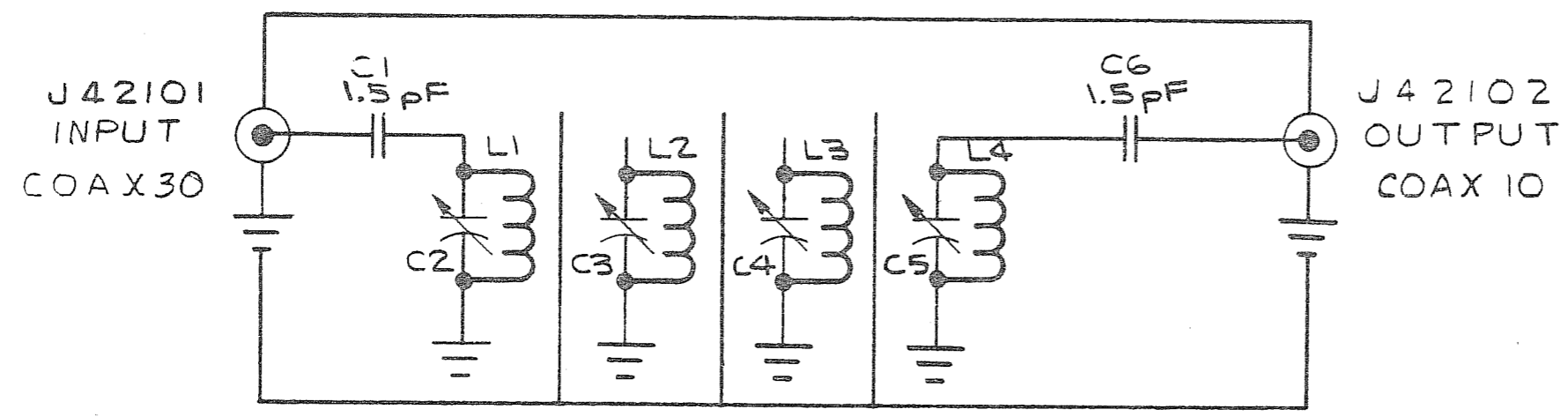

NOTES:

1. C2 THRU C5 ARE VC266 "JFD"/EQUIV. TRIMMER CAPS.
2. L1 THRU L4 ARE 9 TURNS #22 GAUGE ENAMEL COATED COPPER WIRE WOUND ON 7/16 DIA COIL FORMS PLACED AROUND C2 THRU C5.

QTY	MODEL	ITEM	REQ'D	PART NO.	DESCRIPTION
1	FM/AM-1000	1	1	23-0421	108 MHz FILTER SCHEM.
APPLICATION			LIST OF MATERIALS		
<b>TOLERANCES</b> UNLESS OTHERWISE SPECIFIED ALL DIMENSIONS APPLY AFTER FINISH DECIMALS: .xx = ± .010 .xxx = ± .005 ANGLES: ± 1/2° FRACTIONS: ± 1/64 SURFACE ROUGHNESS 125 ✓ REMOVE ALL BURRS			<b>INSTRUMENT FLIGHT RESEARCH CORPORATION</b> WICHITA, KANSAS. TITLE 108 MHz FILTER SCHEMATIC FM/AM-1000		
DRAWN DATE <i>JUN 5/21/75</i> CHECKED DATE APPROVED DATE			SIZE PART NUMBER 1-23-0421		REV A
MATERIAL			SCALE		WEIGHT
TREATMENT			SHEET 1 OF 1		
FINISH					

DATE	REV	CHANGE	APPRO
4-15-76	A	INC ECN #1419 & 1426 SSO	MLL
4-26-76	B	INCORP ECN #1430 WJ SSO	MLL
4-29-76	C	INCORP ECN #1430 WJ SSO	MLL
6-7-76	D	INCORP ECN #1474 RKK WJ	MLL
7-30-76	E	INC ECN'S #1492 & 1584 WJ	MLL
8-26-76	F	INC ECN 1745 RKK WJ	MLL
2-17-77	G	INC ECN 1900 WJ	MLL
2-20-77	H	INCORP ECN #1965 JNV RKK	MLL
2-24-77	J	INCORP ECN #2288 LVC WJ	MLL
4-1-77	K	INC ECN 2244 JNS WJ	MLL
4-1-77	L	INC ECN 2222 WJ	MLL
4-1-77	M	INC ECN #3042 LW WJ	MLL

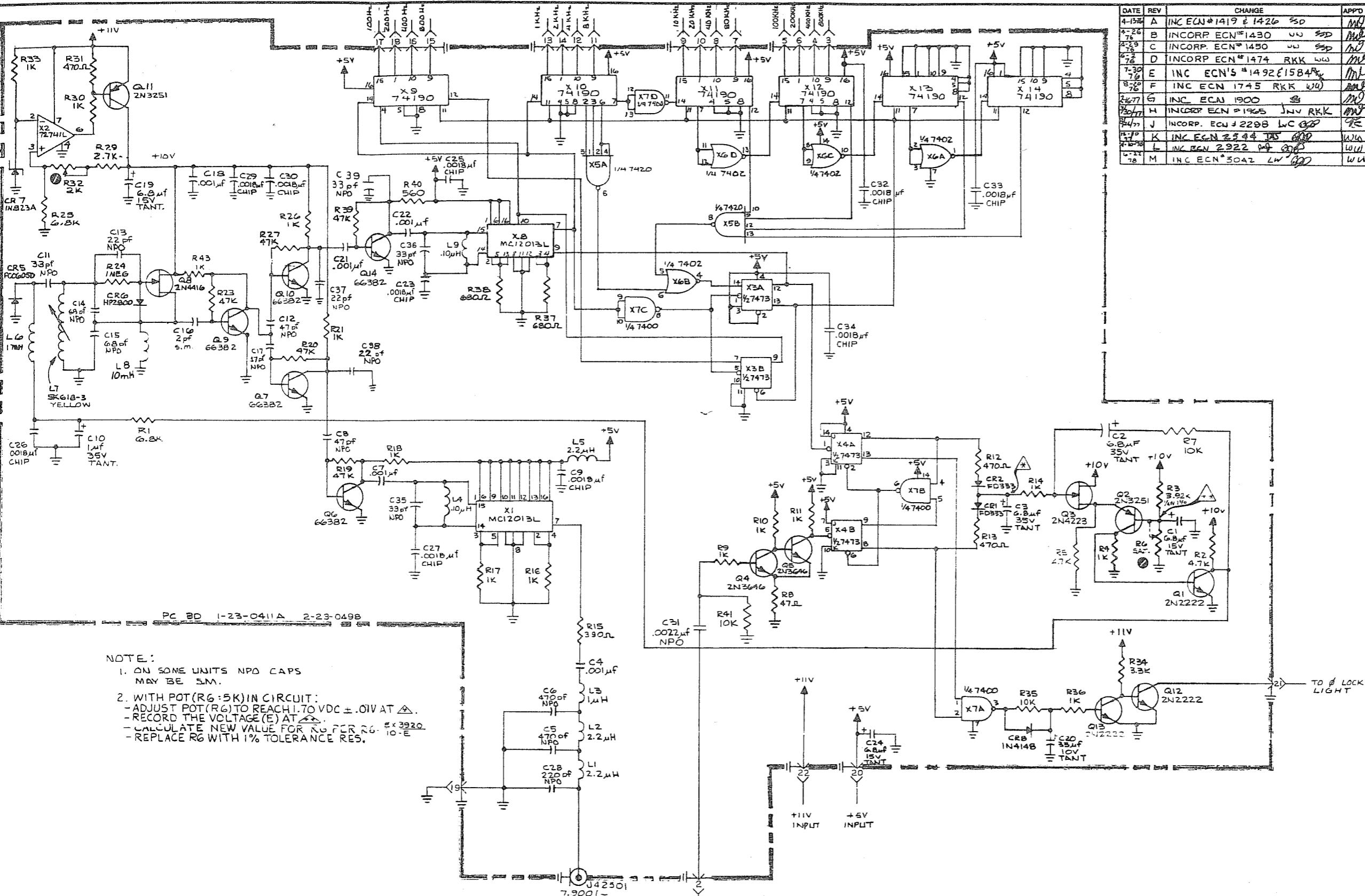

PC BD 1-23-0411A 2-23-0498

NOTE:  
 1. ON SOME UNITS NPO CAPS MAY BE SM.  
 2. WITH POT (R6:5K) IN CIRCUIT:  
 - ADJUST POT (R6) TO REACH 1.70 VDC ± 0.01V AT Δ.  
 - RECORD THE VOLTAGE (E) AT Δ.  
 - CALCULATE NEW VALUE FOR R6 PER R6 = E × 3920.  
 - REPLACE R6 WITH 1% TOLERANCE RES.

J42501  
 7.9001 -  
 8.000 MHz  
 OUTPUT  
 COAX 23

LAST NUMBERS USED:  
 Q14  
 R42  
 CR8 (3 & 4 NOT USED)  
 L9  
 C38  
 X14

23-424	1	FM-AM1000A	1	1	23-425	SCHEMATIC
NEXT ASSY	QTY	MODEL	ITEM REQ'D	PART NO.	DESCRIPTION	
APPLICATION			LIST OF MATERIALS			
TOLERANCES		DRAWN		DATE		INSTRUMENT FLIGHT RESEARCH CORPORATION WICHITA, KANSAS.
UNLESS OTHERWISE SPECIFIED		7-22		76		
ALL DIMENSIONS APPLY AFTER FINISH		CHECKED		DATE		
DECIMALS: 18 = 0.000000000000000000		7-27-75		TITLE		
ANGLES: 1/2		APPROVED		DATE		79-80 MHz LOOP SCHEMATIC FM/AM 1000A
FRACTIONS: 1/64		DATE		REV		
SURFACE FINISHES		DATE		REV		
REMOVE ALL BURRS		DATE		REV		
MATERIAL	SIZE		PART NUMBER		REV	
TREATMENT	C		3-23-425		M	
FINISH	SCALE		WEIGHT		SHEET 1 OF 1	

DATE	REV	CHANGE	APP'D
4/17/75	A	INCORPORATED ECN # 205 SSD DLP	MD
5/1/75	B	INCORP ECN # 1164	MD
7/1/75	C	INCORP ECN # 1911 & 1959	MD
7/29/77	D	INCORPORATED ECN # 2002	JWR
7/31/75	E	INCORP ECN # 2388 & 2403 LC	MD
11-2-78	F	INC ECN 2709	JR
1-22-78	G	INC ECAI 2951	JR

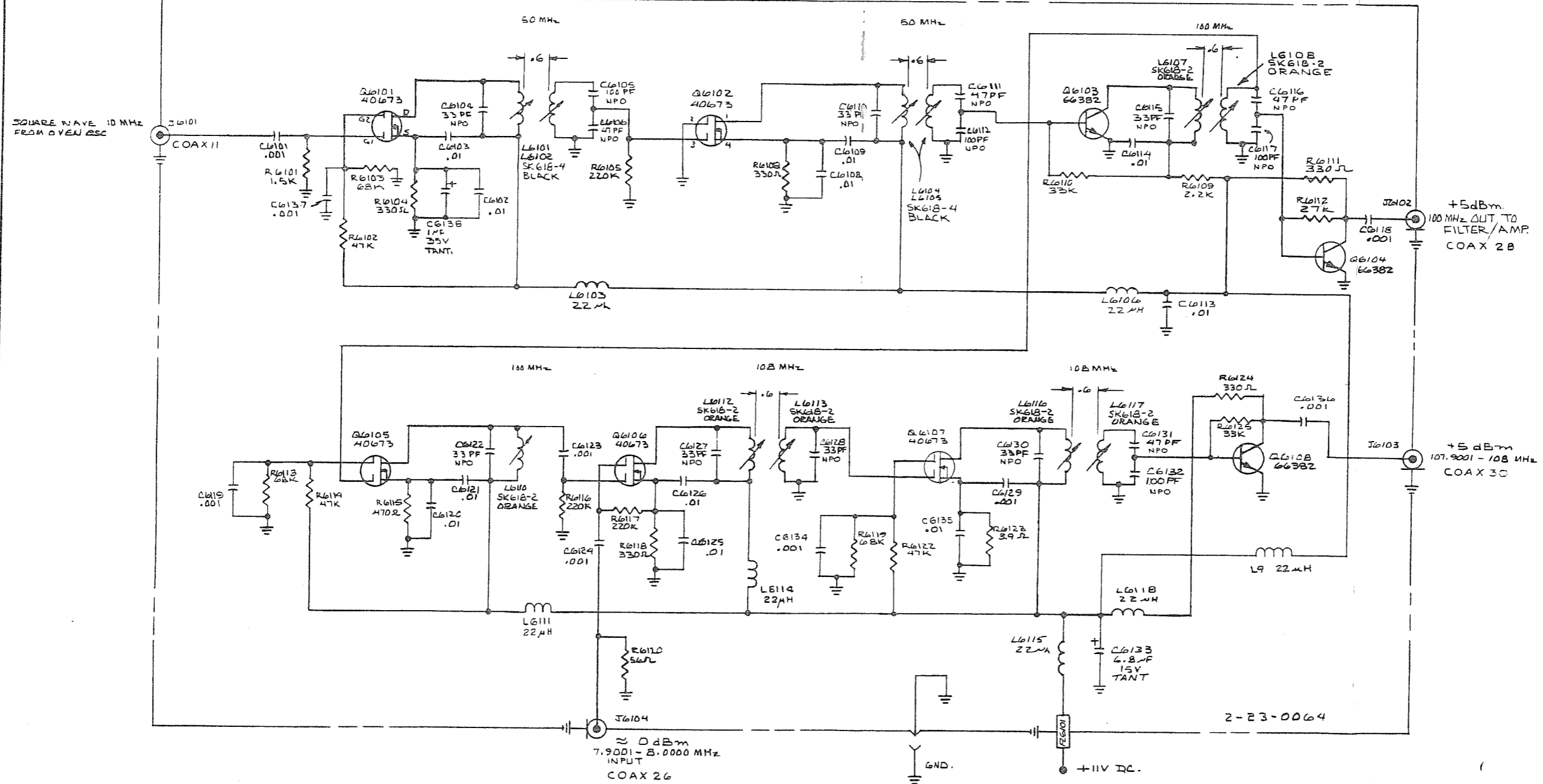

NOTE:  
 1. LAST USED NUMBERS:  
 R 6125  
 C 6136  
 L 6118

23-0095	MM-FM-100	23-0061	SCHEMATIC	
NEXT ASSY	QTY	MODEL	ITEM REQ'D	PART NO.
APPLICATION		LIST OF MATERIALS		
TOLERANCES		DATE	INSTRUMENT FLIGHT RESEARCH CORPORATION	
UNLESS OTHERWISE SPECIFIED		2-26-79	WICHITA, KANSAS	
ALL DIMENSIONS APPLY AFTER FINISH		CHECKED DATE	TITLE	
DECIMALS: .01 - .010 .001 - .001		7/5 4-7-77	100 MHz MULT. &	
ANGLES: 1/2°		APPROVED DATE	108 MHz MIXER	
FRACTIONS: 1/16		MD 12/9/75		
SURFACE FINISH: 125				
REMOVE ALL BURRS				
MATERIAL	SCALE	PART NUMBER	REV	
FINISH	C	3-23-0061	G	
		WEIGHT		
		SHEET	OF	







DATE	REV	CHANGE	APP'D
2/17/75	A	INCORPORATED ECN #291	SSD
9-5-75	B	INCORPORATED ECN #983	SSD
2/19/77	C	INCORP. ECN #1958	JNV
1-18-76	D	INC. ECN 2709	JW

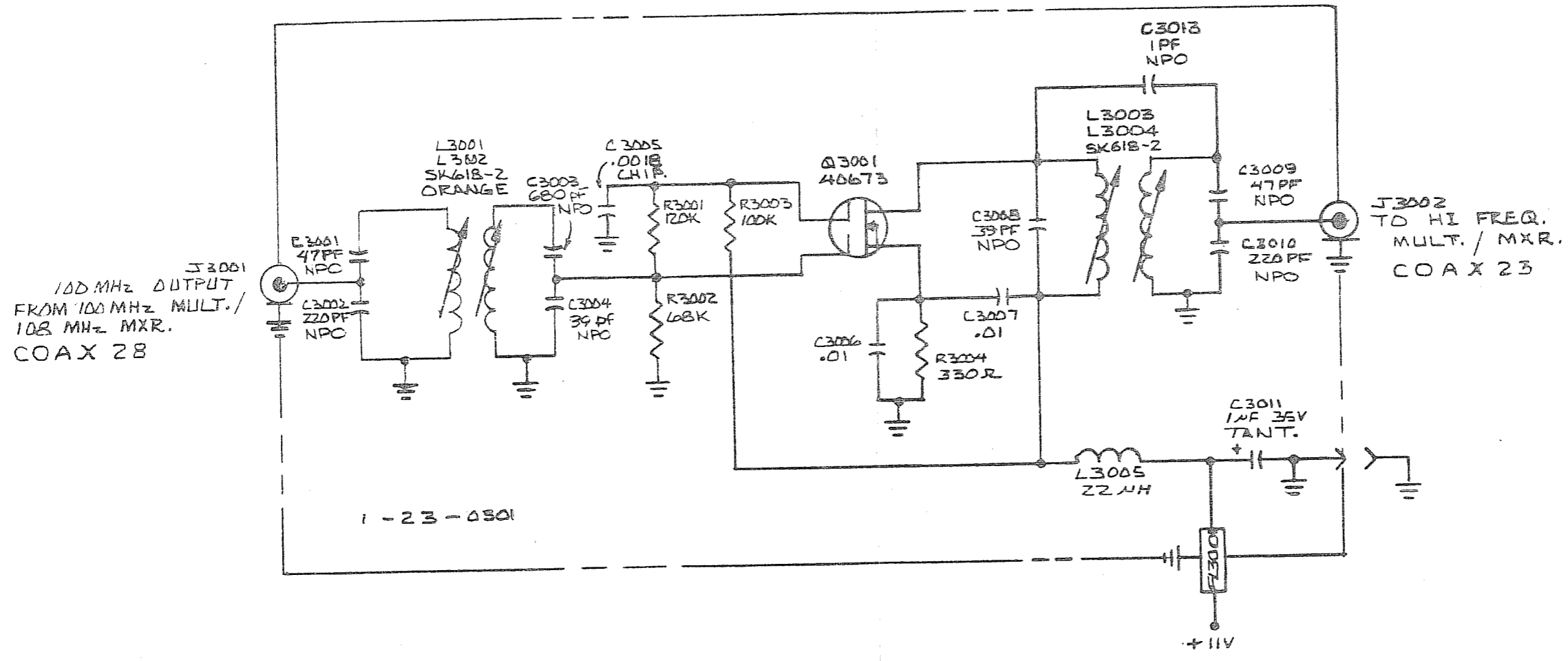

1-23-0301  
ARTWORK

23-0303	FM-1000	-1	1	09-0300	SCHEMATIC	
NEXT ASS'Y	QTY	MODEL	ITEM	REQ'D	PART NO.	DESCRIPTION
LIST OF MATERIALS						
APPLICATION			INSTRUMENT FLIGHT RESEARCH CORPORATION WICHITA, KANSAS			
TOLERANCES UNLESS OTHERWISE SPECIFIED ALL DIMENSIONS APPLY AFTER FINISH			TITLE 100MHz FILTER SCHEMATIC FM-1000			
DECIMALS: ± .000			DRAWN DATE B -7-25-74			
ANGLES: ± 1/2°			CHECKED DATE RR 7-25-74			
FRACTIONS: ± 1/64			APPROVED DATE JNV 2-13-75			
SURFACE ROUGHNESS 125			MATERIAL			
REMOVE ALL BURRS			TREATMENT			
MATERIAL			FINISH			
SIZE B			PART NUMBER 2-23-0300			
SCALE			WEIGHT			
SHEET 1 OF 1			REV D			

DATE	REV	CHANGE	APP'D
8-22-77	D	ORIGINAL RELEASE TJT	<i>TJT</i>
1-18-78	G	INC ECN 2709 JAJ	<i>JAJ</i>

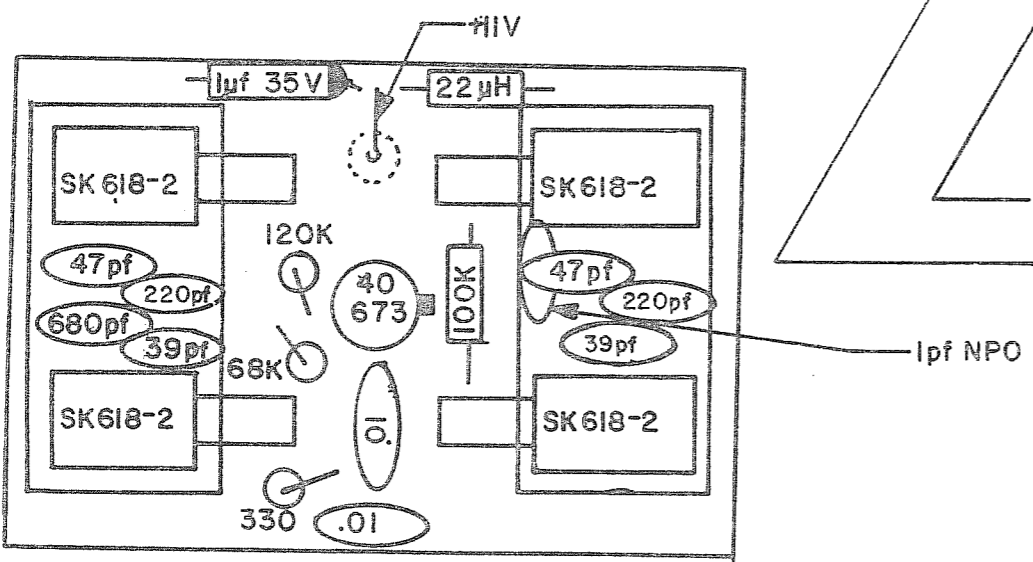
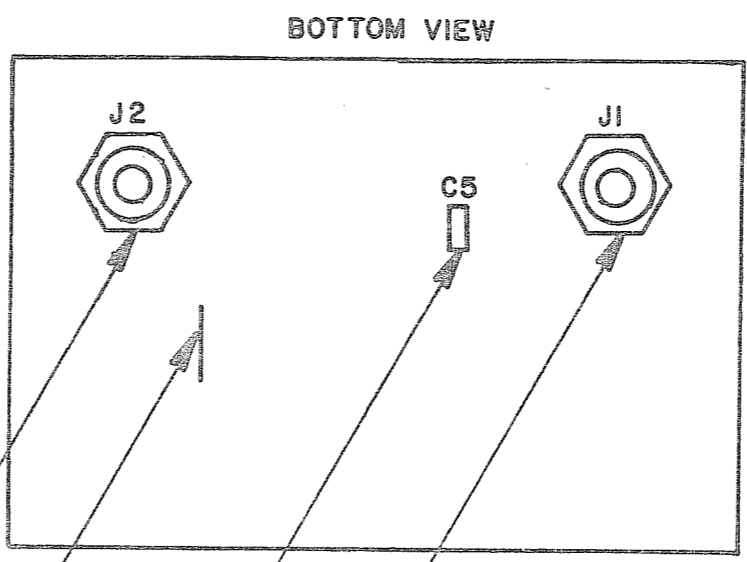
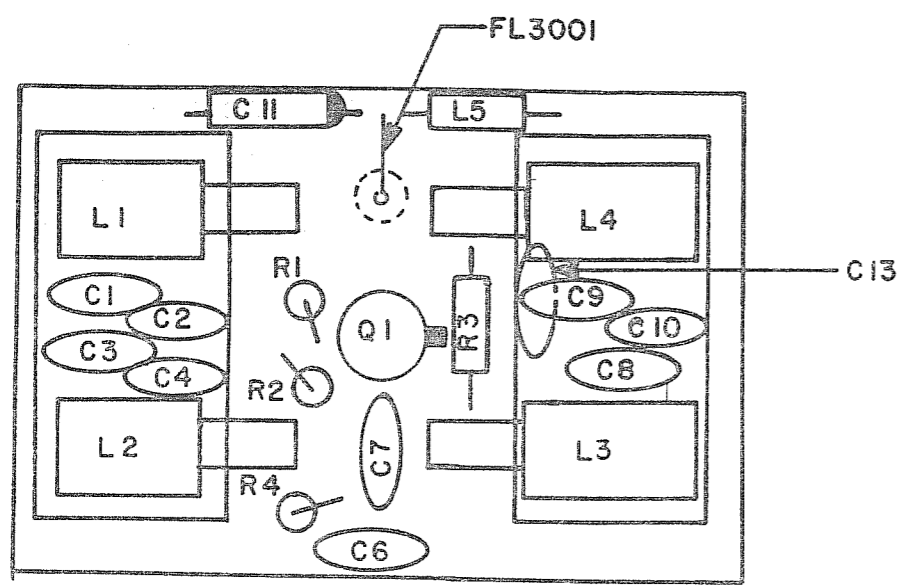

PC BD: 1-23-0301  
SCHEMATIC: 2-23-0300

**NOTES:**

1. ALL RESISTORS ARE 1/4 W., 10% TOLERANCE EXCEPT AS NOTED.
2. ALL CAPACITOR VALUES ARE IN  $\mu$ F EXCEPT AS NOTED, AND ARE NPO.
3. COMPONENT LEADS MAY EXTEND .04 TO .06 BEYOND BOTTOM OF BOARD AFTER SOLDERING.
4. MAXIMUM HEIGHT OF COMPONENTS TO BE .35 FROM COMPONENT SIDE OF BOARD.
5. PLACE CHIP CAPACITORS ON BACK SIDE OF BOARD.
6. ALL COMPONENT DESIGNATORS HAVE 300 PREFIX; i.e. R3001, Q3001, etc.

23-0591	1	FM/AM1000S				
23-0591	1	FM/AM1000A				
NEXT ASS'Y	QTY	MODEL	ITEM	REQ'D	PART NO.	DESCRIPTION
APPLICATION			LIST OF MATERIALS			
TOLERANCES UNLESS OTHERWISE SPECIFIED ALL DIMENSIONS APPLY AFTER FINISH DECIMALS: $\pm .005$ ANGLES: $\pm 1/2^\circ$ FRACTIONS: $\pm 1/32$ SURFACE ROUGHNESS 125 REMOVE ALL BURRS			DRAWING DATE TJT 8/22/77		INSTRUMENT FLIGHT RESEARCH CORPORATION WICHITA, KANSAS	
MATERIAL			CHECKED DATE		TITLE 100 MHz FILTER PC BOARD ASSEMBLY	
TREATMENT			APPROVED DATE		SIZE B	
FINISH			PART NUMBER 2-23-0303		REV G	
SCALE 2:1			WEIGHT		SHEET 1 OF 1	

DATE	REV	CHANGE	APPRO
11-13-74	A	INC ECN # 1	MW
5-15-75	B	INC ECN 568 DLF/GLD	MW
7-2-75	C	INCORP ECN # 856 TO DLF	MW
9-8-75	D	INCORP ECN # 944 TO	MW
12-19-75	E	INCORP ECN # 1180	MW
3-16-76	F	INCORP ECN # 1340	MW
4-13-76	G	INCORP ECN # 1423	MW
5-26-76	H	INCORP ECN # 1470	MW
7-9-77	J	INCORPORATED ECN # 1995	MW
11-9-78	K	INC ECN 2620	MW

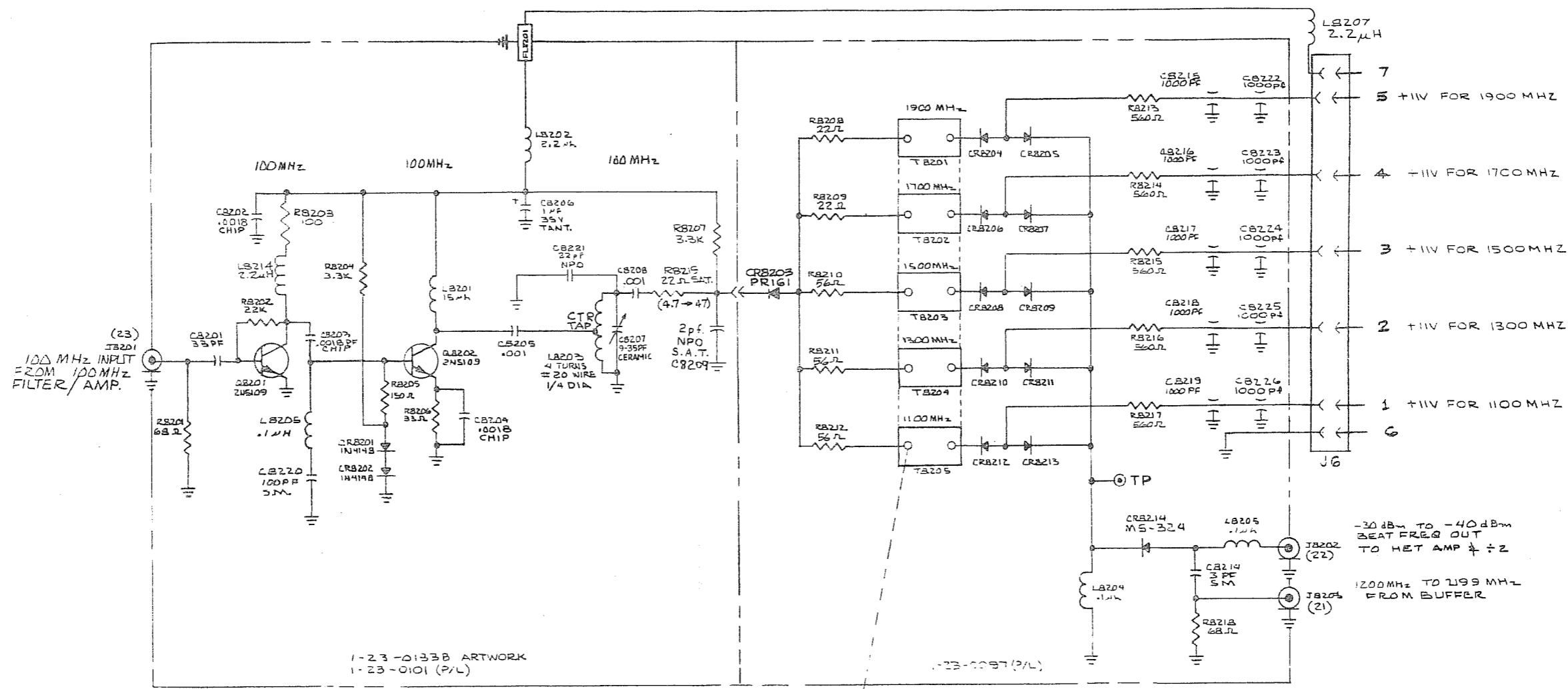

NOTE:  
ALL UN MARKED  
DIODES ARE M447047

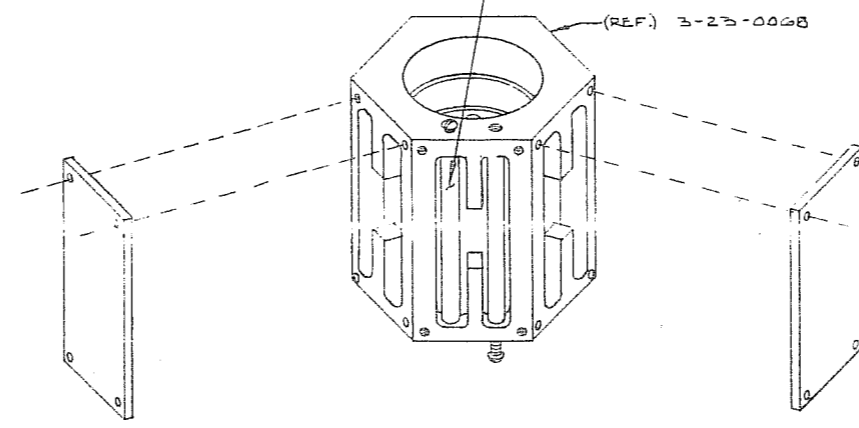

LAST USED PARTS  
CB219  
CB221  
CB214  
TB205  
CB202  
LB205

P/LIST 1-23-0097

23-0097	1	FM/AM 1000		23-0082	SCHEMATIC
NEXT ASSY	QTY	MODEL	ITEM REQ'D	PART NO	DESCRIPTION
LIST OF MATERIALS					
APPLICATION		DRAWN DATE	INSTRUMENT FLIGHT RESEARCH CORPORATION WICHITA, KANSAS.		
TOLERANCES		CHECKED DATE	TITLE		
UNLESS OTHERWISE SPECIFIED			HI-FREQ.		
ALL DIMENSIONS APPLY AFTER FINISH			MULT. MIXER.		
DECIMALS: 18 = + .010, 22 = + .005			(SCHEMATIC)		
ANGLES: 1/2"					
FRACTIONS: 1/16"					
SURFACE FINISH: REMOVE ALL BURRS					
MATERIAL		APPROVED DATE	SIZE	PART NUMBER	REV
			C	3-23-0082	K
TREATMENT			SCALE	WEIGHT	
FINISH					
					SHEET 1 OF 1

DATE	REV	CHANGE	APP'D
9/2/75	A	INC ECN 2949 JAJ	WJ
9/15/75	A	INC ECN 2949 JGF	WJ

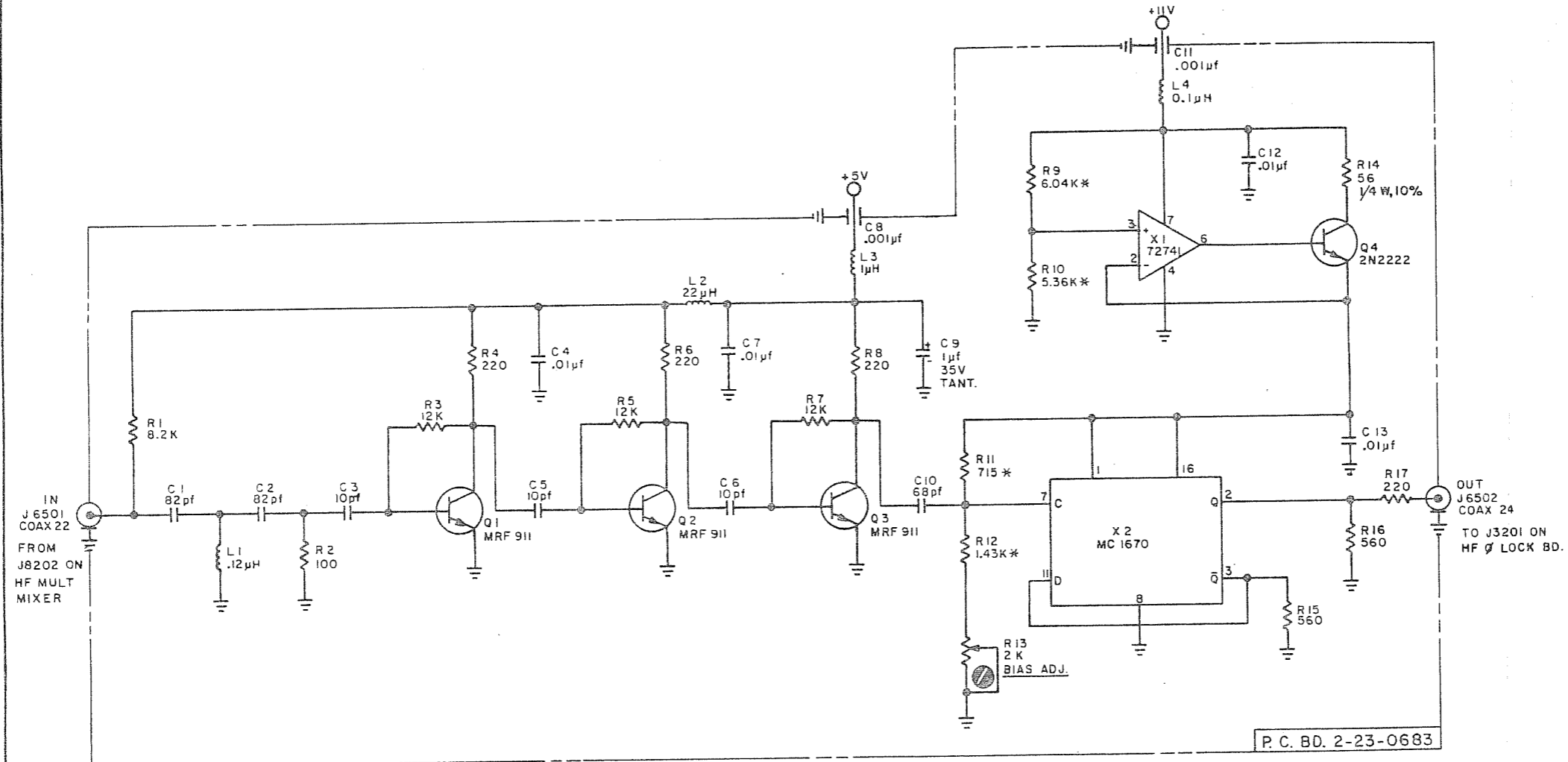

EFFECTIVE: FM/AM1000A S/N 1170 8 ON

- NOTES:
1. ALL RES. ARE 1/8W, 10% TOL. EXCEPT AS NOTED.
  2. THOSE CAPACITORS CALLED OUT IN PF ARE NPOS
  3. "\*" DENOTES 1/4W, 1% TOL. RES.

3-23-0683	HET. AMP ÷ 2 PRESCALER
<p>HET. AMP ÷ 2 PRESCALER</p>	
3-23-0685	A

DATE	REV	CHANGE	APPD

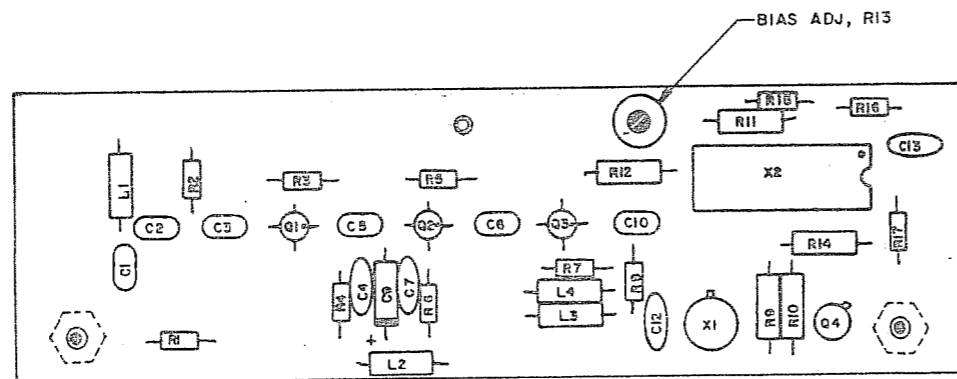

REF DWG:  
PC BOARD 2-23-0683  
SCHEMATIC 3-23-0685

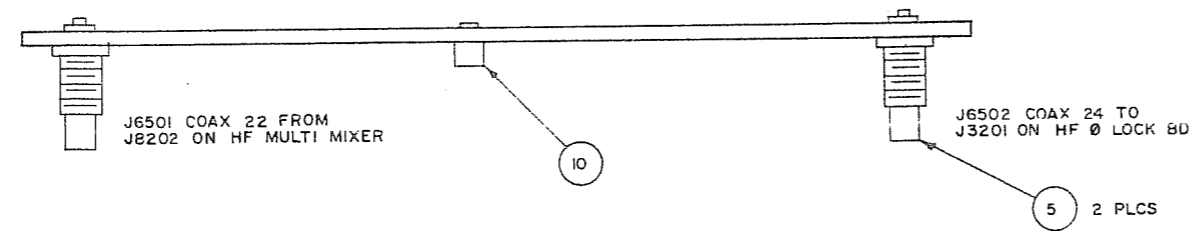
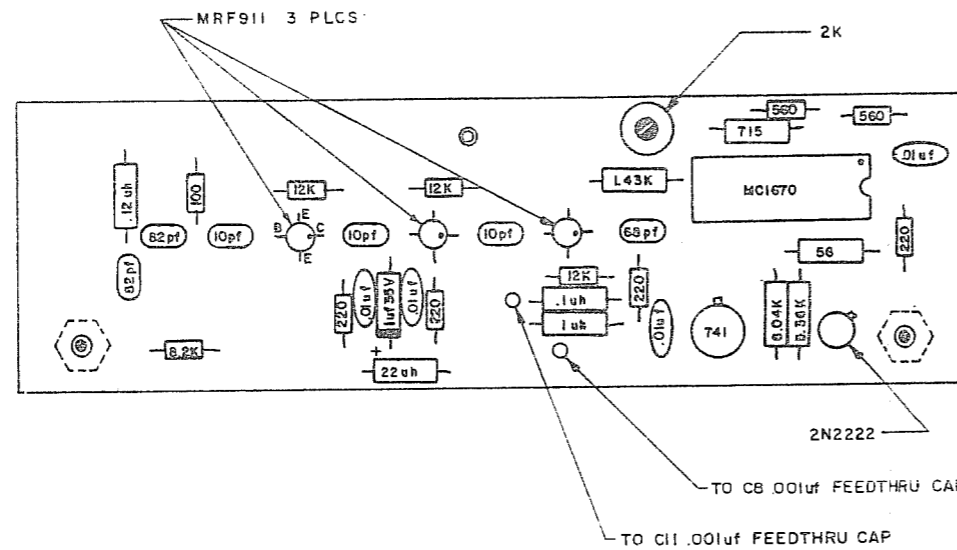

- NOTES:
1. C1 - C3, 5, 6, 10 ARE NPO CAPS
  2. R1 THRU R8, R15 THRU R17 ARE 1/8W, 10%
  3. R14 IS 1/4W, 10%
  4. R9, 10, 11, 12 ARE 1/4W, 1%
  5. COMPONENT LEADS MAY EXTEND .04-.06 BEYOND BOTTOM OF BOARD AFTER SOLDERING
  6. MAXIMUM HEIGHT OF COMPONENTS TO BE .35 FROM COMPONENT SIDE OF BOARD.

EFFECTIVE: 1000A S/N 1170 & ON

ITEM	REQ'D	PART NO.	DESCRIPTION
12			
11			
10	1	350-2189-09-07	STANDOFF "CAMBION"/EQUIV
9			
8	A/R	AWG 26	SLEEVING
7	A/R	AWG 26	BUSS WIRE
6			
5	2	17-0204-000	CONNECTOR "AEP"/EQUIV
4			
3	REF	3-23-0685	SCHEMATIC
2	1	2-23-0683	PC BOARD
1	1	1-23-0684	ASSY P/L

23-0225 REV A/M LOGS NET ASST QTY MODEL	APPLICATION	DATE	DATE	DATE
TOLERANCES UNLESS OTHERWISE SPECIFIED ALL DIMENSIONS APPLY AFTER FINISH DECIMALS: .001 - .010 .0025 - .005 FRACTIONS: ± 1/64 ANGLES: ± 1/2° SURFACE ROUGHNESS REMOVE ALL BURRS		DRAWN J. V. V. 4-14-78	CHECKED DATE	APPROVED DATE
MATERIAL		SCALE	PART NUMBER	REV
FINISH		2 x 1	3-23-0684	
		WEIGHT	SHEET 1 OF 1	

DATE	REV	CHANGE	APPD
5/9/75	A	INCORPORATED ECN #664	MD
4/1/76	B	INCORP. ECN #1378	MD
4/2/76	C	INCORP. ECN #1432	MD
7/27/77	D	INCORP. ECN # 2000, 2005	MD
1/24/78	E	INCORP. ECN # 2279	MD
11/1/78	F	INC. ECN 2709	MD

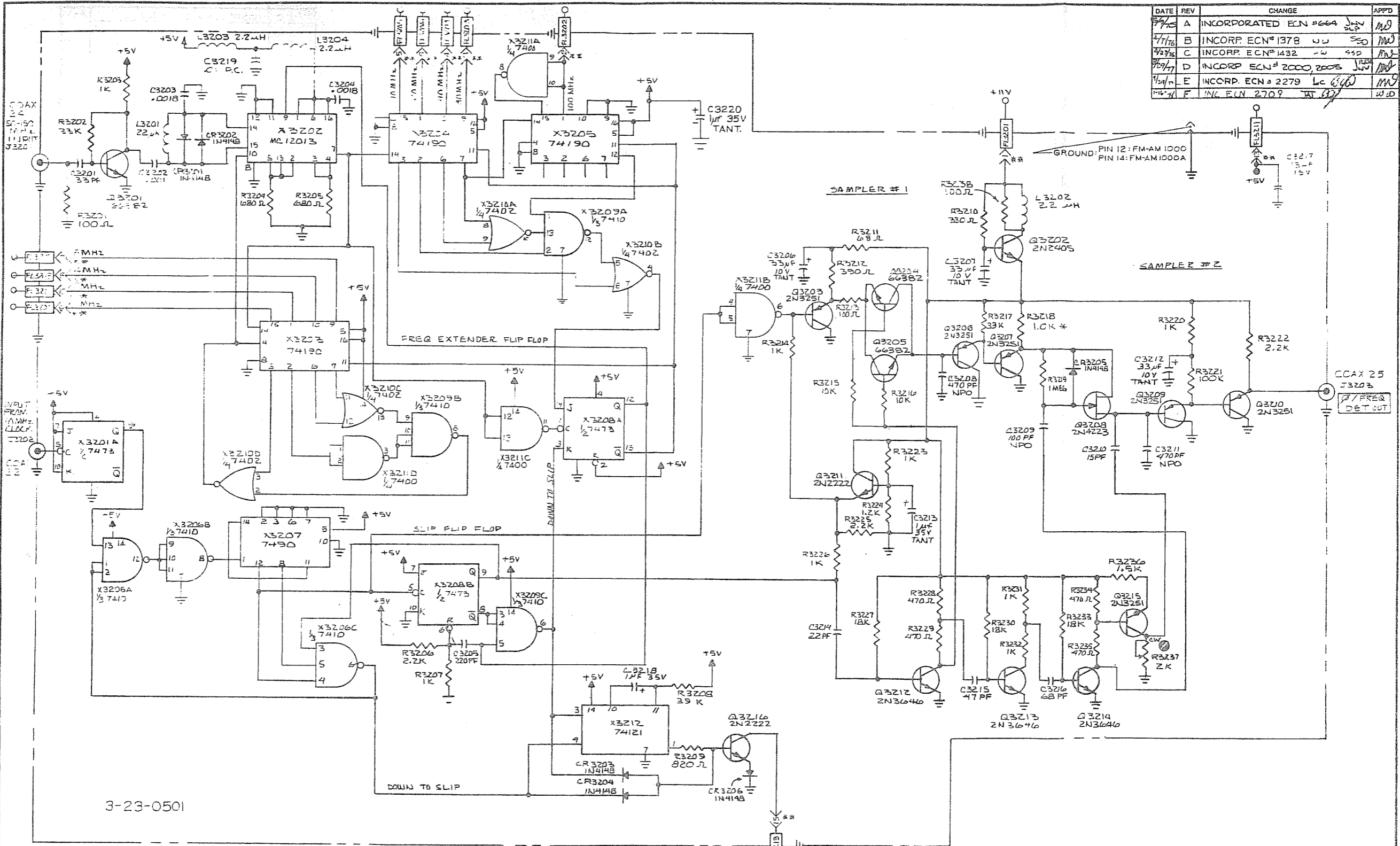

3-23-0501

- NOTE:
- COMPONENTS MARKED \* ARE 1%.
  - CONNECTIONS MARKED \* REFER TO FM-AM 1000A ONLY; FEED-THRU FILTERS APPEAR ON FM-AM 1000 ONLY.
  - Q3209 (2N3251) WAS 2N5462 AND RESISTOR R3221 (100K) WAS 6.8K ON UNITS PRIOR TO SN 537.

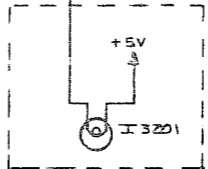

DATE	REV	CHANGE	APPD
3-23-0493	1	FM-AM1000A	MD
3-23-0398	1	SCHEMATIC	MD

APPLICATION	LIST OF MATERIALS
TOLERANCES UNLESS OTHERWISE SPECIFIED ALL DIMENSIONS APPLY AFTER FINISH	INSTRUMENT RESEARCH CORPORATION WICHITA, KANSAS
ANGLE: 2 1/2°	TITLE: HIGH FREQ. & LOCK CKT
FRACTIONS: 2/128	DATE: 3-23-0396
SURFACE FINISH: REMOVE ALL BURRS	SCALE: NONE
MATERIAL: _____	REV: F
TREATMENT: _____	SHEET: 1 OF 1
FINISH: _____	





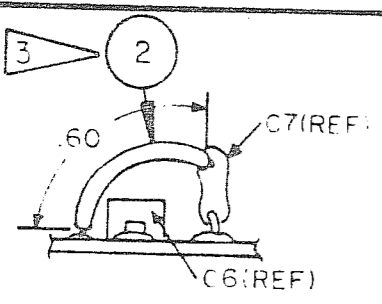

DETAIL A  
(NOT TO SCALE)

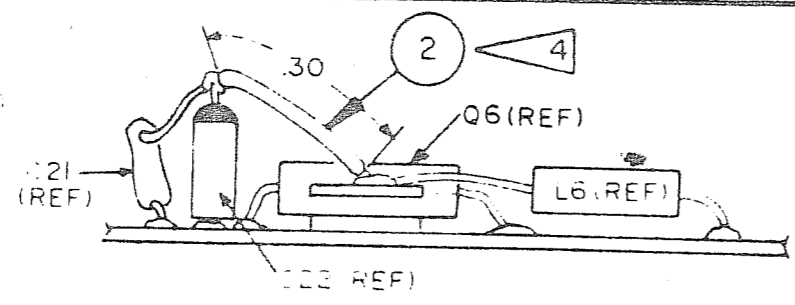

DETAIL B (NOT TO SCALE)

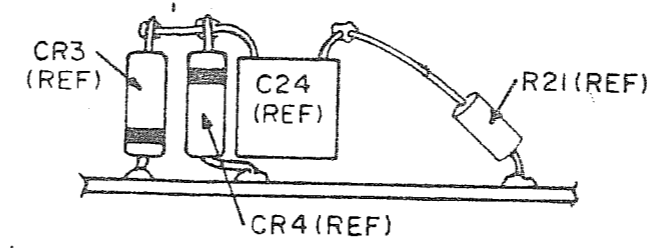

DETAIL C (NOT TO SCALE)

DATE	REV	CHANGE

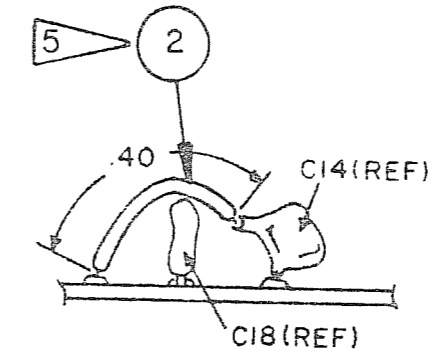
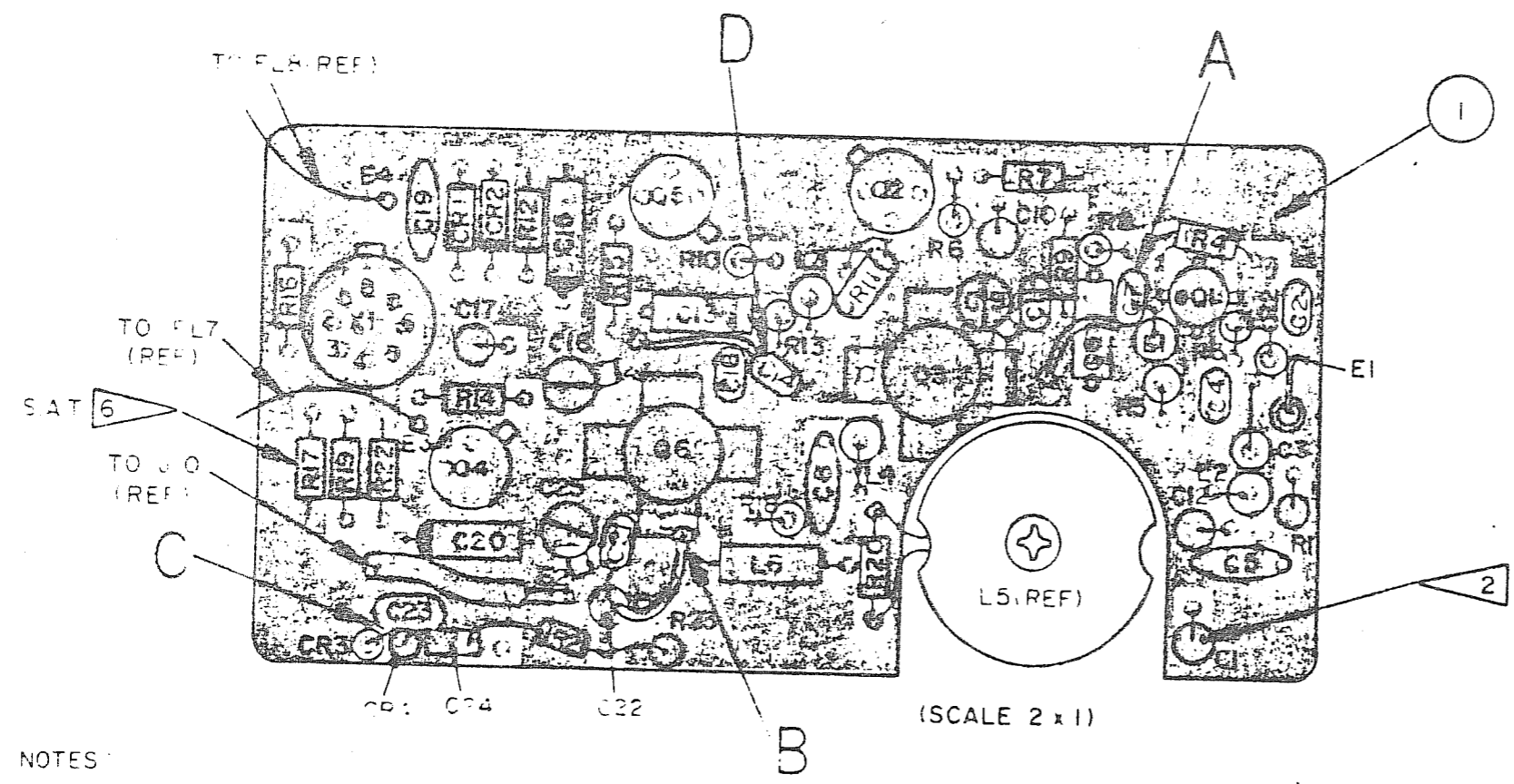

DETAIL D  
(NOT TO SCALE)

- NOTES:
1. REFERENCE TO FL7 SCHEMATIC DRAWING 237-800
  2. ALL TRANS CAPS MOUNTED VERTICALLY ARE POSITIVE END UP
  3. USE 1/8" DIA SLEEVE # 050-0000-115) 60 LONG ON C7 LEAD TO ASSURE SAME LEAD LENGTH ON EVERY INSTALLATION.
  4. USE 1/8" DIA SLEEVE # 050-0000-115) 30 LONG FROM +C22 LEAD TO COLLECTOR OF Q6 TO ASSURE SAME LEAD LENGTH ON EVERY INSTALLATION.
  5. USE 1/8" DIA SLEEVE # 050-0000-115) 40 LONG ON C14 LEAD TO ASSURE SAME LEAD LENGTH ON EVERY INSTALLATION.
  6. R17 SET AT TEST (SAT RANGE: NOMINAL ~~39K~~, RANGE: 39K OR 33K).
  7. ALL PCB BOARD COMPONENTS CARRY AN 80000 SERIES REFERENCE DESIGNATOR (E.G. Q5 IS Q80005 AND R22 IS R80022).

ITEM	REQ'D	PART NO	DESCRIPTION

23-725	1	1000S	NEXT ASSY QTY MODEL	APPLICATION	TOLERANCES IN. UNLESS OTHERWISE SPECIFIED ALL DIMENSIONS APPLY AFTER FINISH DECIMALS: .010 MAX .005 ANGLES: 1/2" FRACTIONS: 1/64 SURFACE ROUGHNESS: 125 REMOVE ALL BURRS		DRAWN: ER 4/25/80 CHECKED: J. Adams 80 APPROVED: [Signature] 11/6/80	DATE: 11-6-80 TITLE: HIGH LEVEL AMP P.C. BOARD ASSY. FM-AM 1000S
					MATERIAL: //	FINISH: //	SIZE: B PART NUMBER: 7010-2372-100 SCALE: NOTED WEIGHT: //	SHEET 1 OF 1

DATE	REV	CHANGE	APP'D

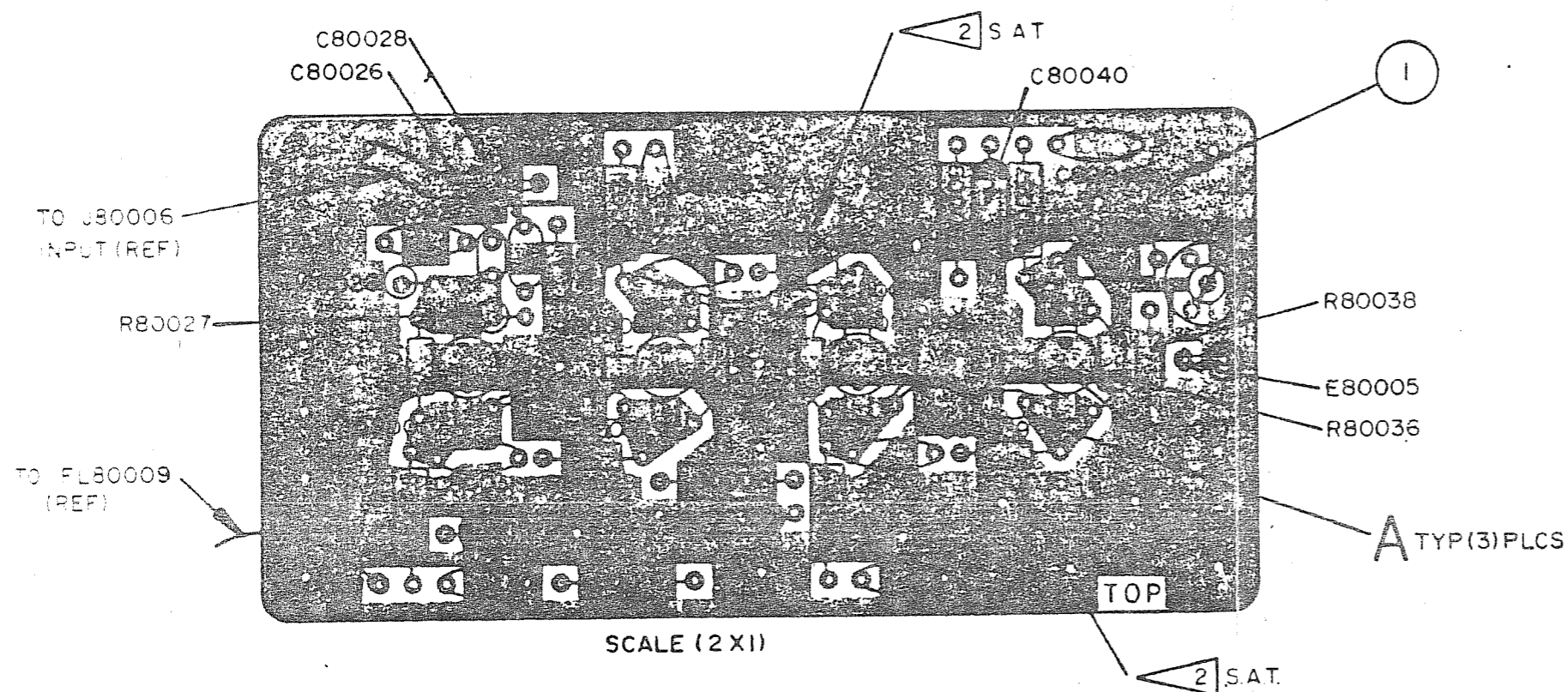
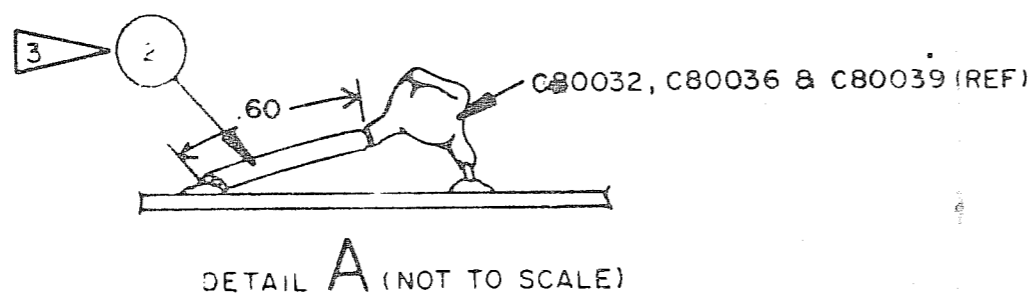

NOTES:

1. REFERENCE CIRCUIT SCHEMATIC 0000-2371-800.
2. R80032 AND R80035 ARE SET AT TEST (S.A.T.) RESISTORS NOMINAL VALUE 3.9KΩ. S.A.T. RANGE: 1.5K TO 3.9K, 1/8W, 10%.
3. USE 26AWG TEFLON SLEEVING (# 1050-0000-115) .60 LONG ON ONE LEAD OF C80032, C80036 & C80039 TO ASSURE SAME LEAD LENGTH ON EVERY INSTALLATION.

ITEM	REQ'D	PART NO	DESCRIPTION
LIST OF MATERIALS			
23-725	1	1000S	APPLICATION
NEXT ASSY QTY MODEL		APPLICATION	
1		1000S	
23-725		APPLICATION	

TOLERANCES		DRAWN DATE	- IFR INC - WICHITA, KANSAS	
UNLESS OTHERWISE SPECIFIED		ER 4/23/80		
ALL DIMENSIONS APPLY AFTER FINISH		CHECKED DATE		
DECIMALS .010 .005		J. Adams 11-6-80		
ANGLES 1/2"		APPROVED DATE	TITLE	
FRACTIONS 1/64 125 J		BOROTA 11/6/80	HIGH LEVEL AMP P.C. BD. #2 ASSY.	
SURFACE ROUGHNESS			FM-AM 1000S	
REMOVE ALL BURRS			SIZE	REV
MATERIAL			B	
FINISH			PART NUMBER	7010-2372-400
			SCALE	WEIGHT
			NOTED	63
			SHEET	1 OF 1

DATE	REV	DESCRIPTION	BY
5/14/5	A	INC ECN 633	SLP
6/17/5	B	INC ECN 800	SLP
10-17-5	C	INCORP ECN #1000	SLP
11-13-5	D	INCORP ECN #1145	SLP
4-13-70	E	INC ECN #1424 & 1385	SLP
7-22-72	F	INC ECN #1569 RKK	SLP
7-29-77	G	INCORP ECN #2012, 1391	SLP
5-14-77	H	INC ECN #2048 T.T	SLP
12-13-77	J	INC ECN 2047	SLP
11-17-79	K	INC ECN 2709	SLP

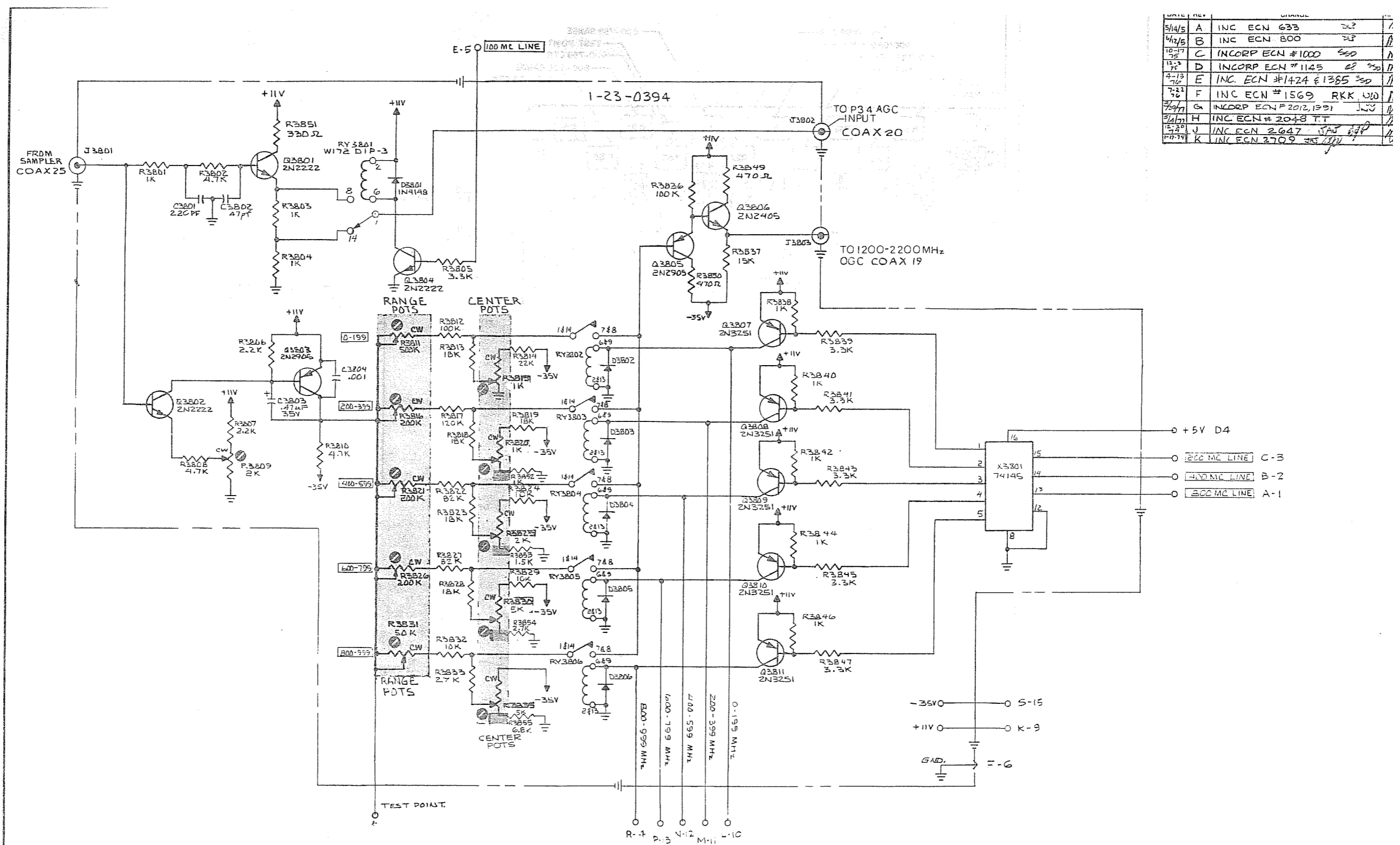

NOTE:  
 1. ALL UNMARKED RELAYS ARE WITH DIP-3  
 2. ALL UNMARKED DIODES ARE IN4148

ARTWORK 2-23-00418 EFFECTIVE  
 PARTS LIST 2-23-0060 3/24/74  
 ARTWORK 2-23-0394 EFFECTIVE  
 PARTS LIST 1-23-0423 3/24/74

DATE	REV	DESCRIPTION	BY
2-23-0422	1	FM/AM-1000	SLP

APPLICATION	LIST OF MATERIALS
TOLERANCES UNLESS OTHERWISE SPECIFIED ALL DIMENSIONS APPLY AFTER FINISH DECIMALS: .XX = ± 0.10 .XXX = ± 0.05 ANGLES: ± 1/2° FRACTIONS: ± 1/64 SURFACE ROUGHNESS 125 REMOVE ALL BURRS	TITLE V.C.O. TUNER FM-1000
DRAWN DATE LD 1-30-74	CHECKED DATE
APPROVED DATE M9 4/5/74	
MATERIAL	SIZE PART NUMBER
TREATMENT	3 3-23-2032 K
FINISH	SCALE WEIGHT SHEET OF 1

DATE	REV	CHANGE	APP'D
8/19/77	E	ORIGINAL RELEASE AA	MD
8/17/77	F	INC ECN 2647	MD
1/27/77	F	INC ECN 2709	MD

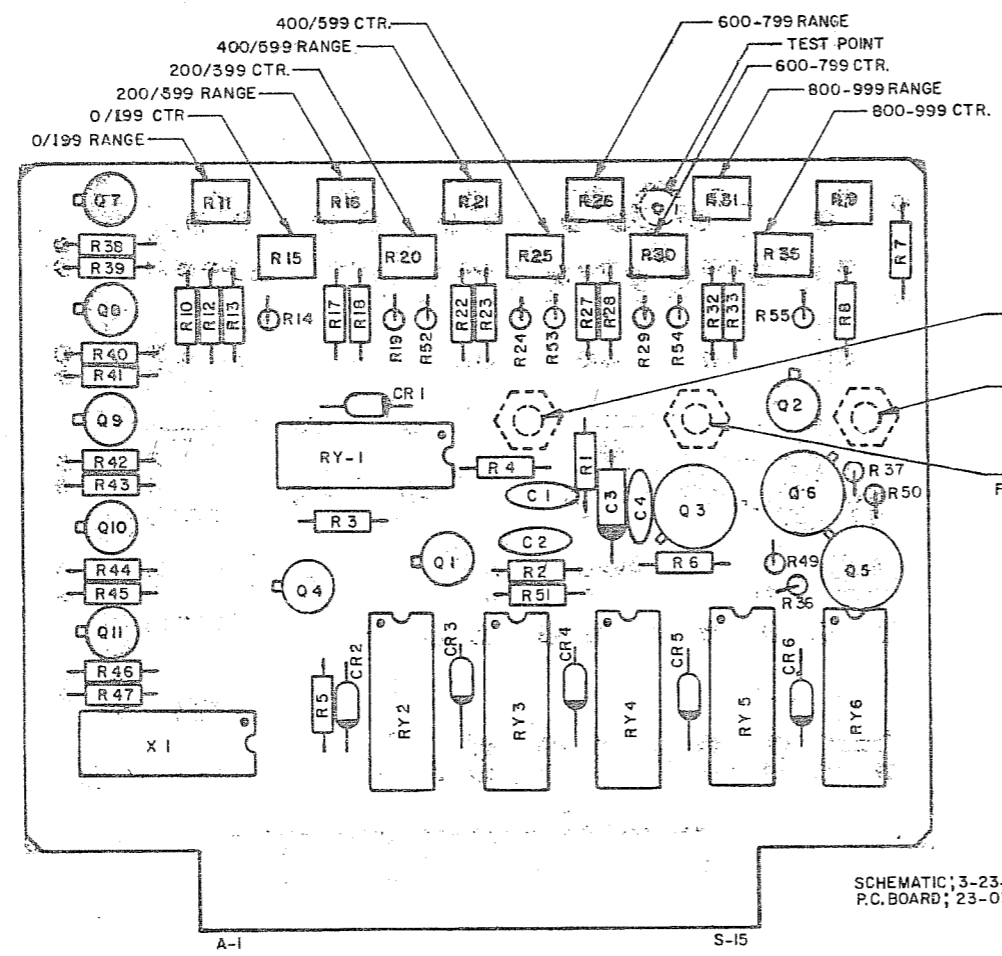

J3802 COAX 20  
TO AGC INPUT

J3803 COAX 19  
TO 1200-2200 MHz  
OSC.

J3801 COAX 25  
FROM SAMPLE

PIN	FUNCTION
A-1	800 MC LINE
B-2	400 MC LINE
C-3	200 MC LINE
D-4	+5V
E-5	100 MC LINE
F-6	GROUND
H-7	NO CONNECTION
J-8	NO CONNECTION
K-9	+11V
L-10	0-199 MHz
M-11	200-399 MHz
N-12	400-599 MHz
P-13	600-799 MHz
R-14	800-999 MHz
S-15	-35V

SCHEMATIC; 3-23-0038  
P.C. BOARD; 23-0394

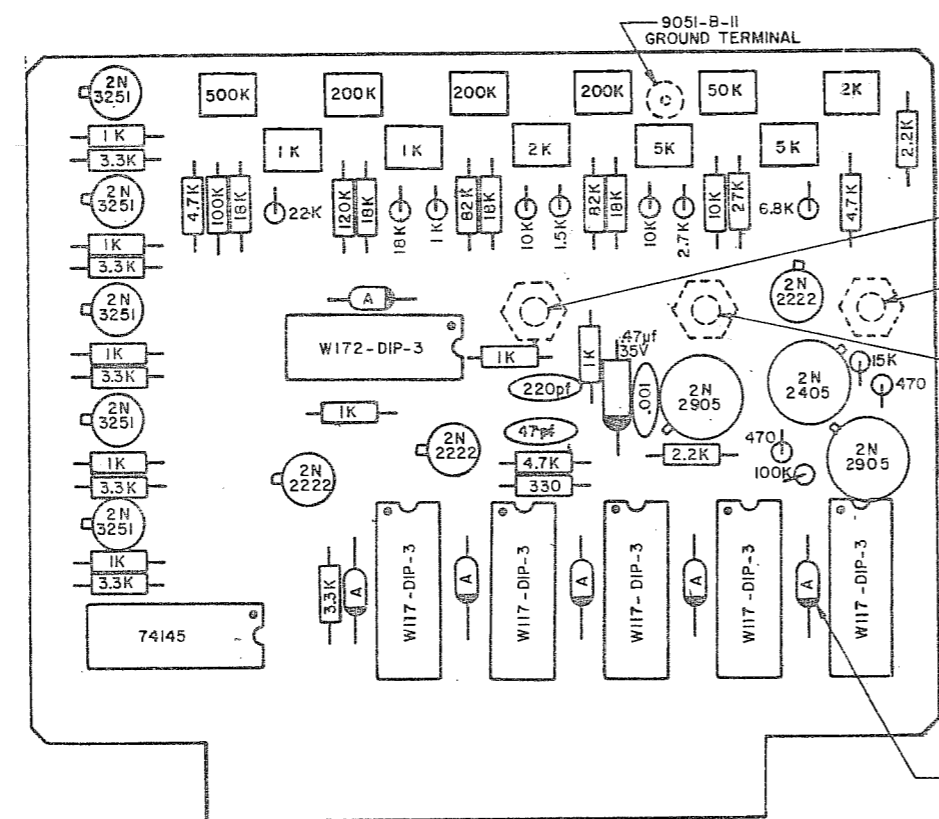

17-0204-000  
SMB MALE COAX CONN.

17-0204-000  
SMB MALE COAX CONN.

17-0204-000  
SMB MALE COAX CONN.

IN4148 (ALL MARKED "A")

NOTES:

1. ALL RESISTORS ARE 1/4 W., 10% TOLERANCE EXCEPT AS NOTED.
2. ALL CAPACITOR VALUES ARE IN  $\mu$ F EXCEPT AS NOTED.
3. COMPONENT LEADS MAY EXTEND .04 TO .06 BEYOND BOTTOM OF BOARD AFTER SOLDERING.
4. MAXIMUM HEIGHT OF COMPONENTS TO BE .35 FROM COMPONENT SIDE OF BOARD.

ITEM	REQ'D	PART NO.	DESCRIPTION
		1-23-0423	P.C. BOARD ASS'Y

APPLICATION		TOLERANCES		DRAWN DATE		TITLE	
1-23-0582	1-1650A	UNLESS OTHERWISE SPECIFIED	ALL DIMENSIONS APPLY AFTER FINISH	8/19/77	8/19/77	- IFR INC - WICHITA, KANSAS	
		DECIMALS: .XX - 5 .010 XXX - 2 .005	ANGLES: $\pm$ 1/2			V.C.O. TUNER P.C. BOARD ASS'Y	
		FRACTIONS: $\pm$ 1/64	SURFACE ROUGHNESS			PART NUMBER 3-23-0423	
		REMOVE ALL BURRS	125			SCALE 2:1	
						WEIGHT	
						SHEET 1 OF 1	

Figure 6-58

DATE	REV	CHANGE	APPD
10-19-68	A	INC ECN #1 L.D.	MJD
11-10-68	B	INC ECN #1205	MJD
12-23-68	C	INCORP ECN #1467 WJ	MJD
1-16-69	D	INCORP ECN #16216 JW	MJD
1-20-69	E	INCORP ECN #17541 AA BG	WJD
1-28-69	G	INCORP ECN #17541 AA BG	WJD

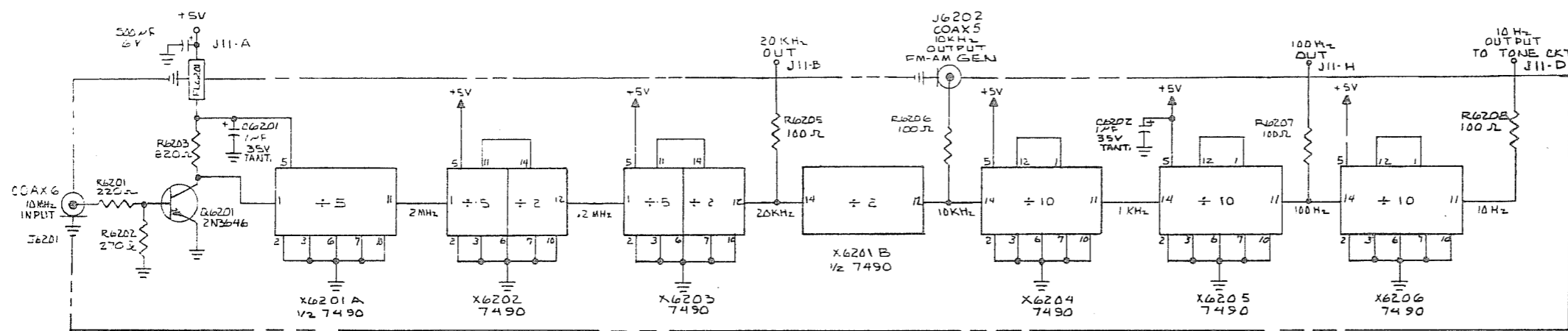

23-0093	1	FM-AM-1000	-	-	23-0062	SCHEMATIC
NEXT ASSY	QTY	MODEL	ITEM	REQ'D	PART NO.	DESCRIPTION
APPLICATION			LIST OF MATERIALS			
TOLERANCES		DRAWN	DATE	INSTRUMENT FLIGHT RESEARCH CORPORATION		
UNLESS OTHERWISE SPECIFIED		5	2-28-70	WICHITA, KANSAS.		
ALL DIMENSIONS APPLY AFTER FINISH		CHECKED	DATE	TITLE		
DECIMALS: .01 - ± .010 .025 - ± .005		1965	2-28-70	CLOCK DIVIDER		
ANGLES: ± 1/2°		APPROVED	DATE	REV		
FRACTIONS: ± 1/64		MJD	12/31/70	G		
SURFACE ROUGHNESS				SCALE	5-23-0062	
REMOVE ALL BURRS				WEIGHT	G	
MATERIAL					SHEET 1 OF 1	
TREATMENT						
FINISH						

DATE	REV	CHANGE	APP'D
10-21-77	G	ORIGINAL RELEASE TJT	
1-18-78	G-1	INC ECN 2709 JPT	

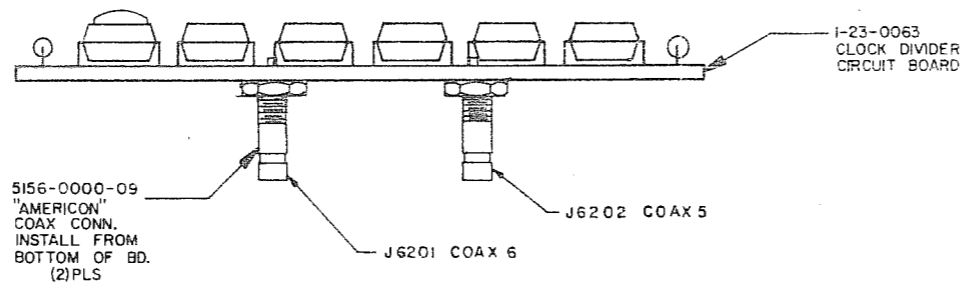
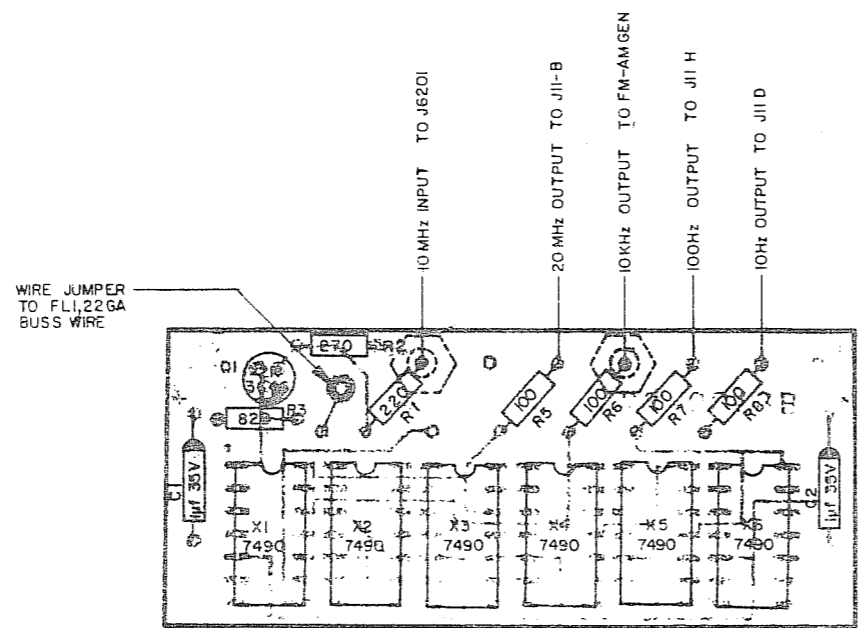

- NOTES:
4. SCHEMATIC NO 3-23-0062
  3. MAXIMUM HEIGHT OF COMPONENTS TO BE .03 FROM COMPONENT SIDE OF BOARD.
  2. COMPONENT LEADS MAY EXTEND .04 TO .06 BEYOND BOTTOM OF BOARD AFTER SOLDERING.
  1. ALL RES. ARE 1/4W, 10%TOL.

ITEM	REQ'D	PART NO.	DESCRIPTION
LIST OF MATERIALS			

23-0217 REV A/B NEXT ASSY QTY: MODEL	TOLERANCES UNLESS OTHERWISE SPECIFIED ALL DIMENSIONS APPLY AFTER FINISH DECIMALS: .03 - ± .010 .048 - ± .005 ANGLES: ± 1/2° FRACTIONS: ± 1/64 SURFACE ROUGHNESS REMOVE ALL BURRS		DRAWN DATE Ten Eyck 10-21-77 CHECKED DATE APPROVED DATE 11-77	TITLE - IFR INC - WICHITA, KANSAS CLOCK DIVIDER PC BOARD ASSEMBLY
	MATERIAL	FINISH	SIZE C	PART NUMBER 3-23-0093 REV G-1
SCALE 2:1			WEIGHT	SHEET 1 OF 1

DATE	REV	CHANGE	APPD
1-20-52	A	INC ECN 1197	RE
1-20-52	B	INC ECN 1239 & 1267	RE
1-20-52	C	INC ECN 1791	RKK
1-20-52	D	INC ECN 2003 TJT	RE
1-20-52	E	INCORP ECN 2346	RE
1-20-52	F	INC ECN 2709	RE
1-20-52	G	INC ECN 2801	RE

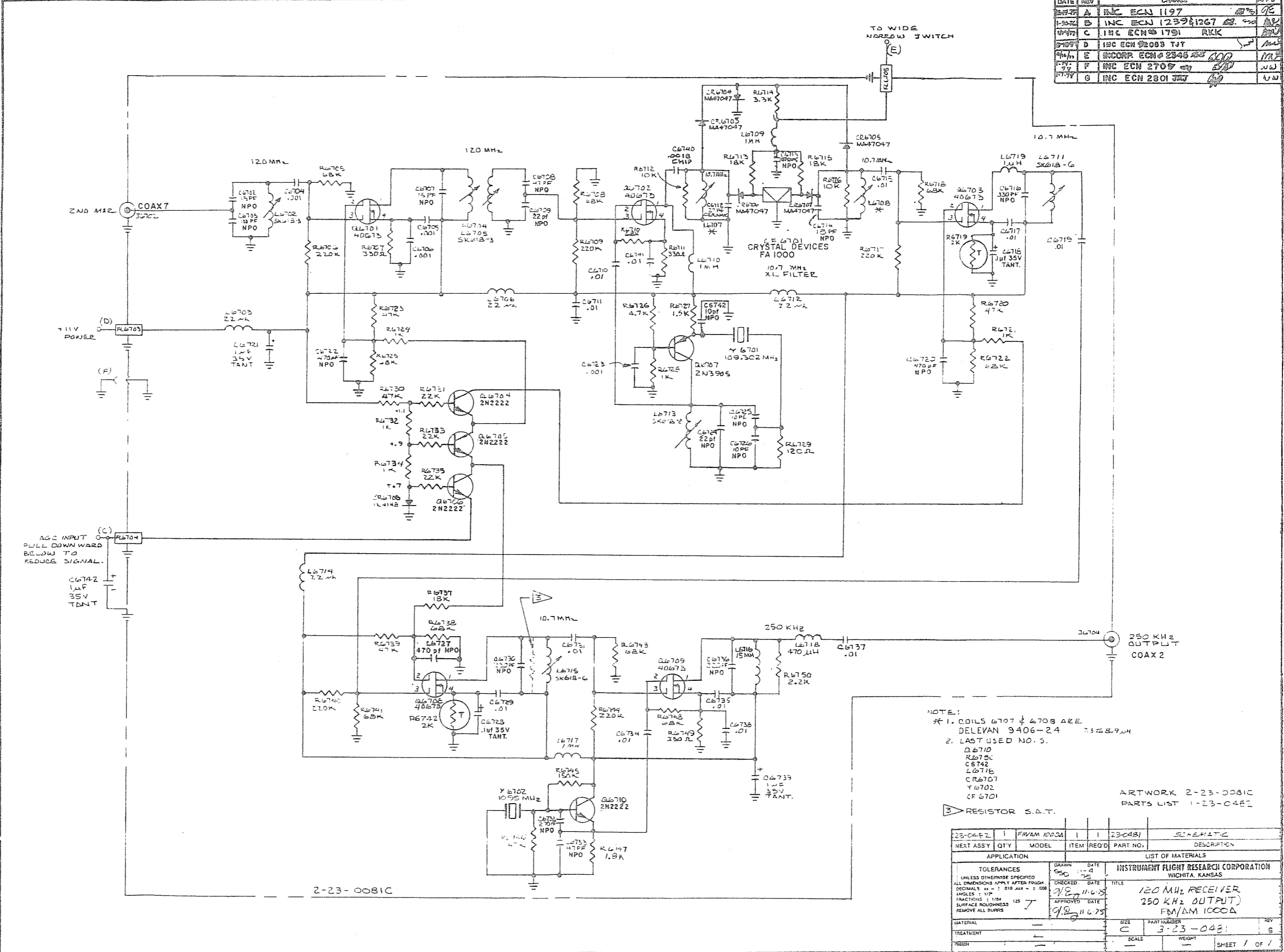

NOTE:  
 \* 1. COILS 6707 & 6708 ARE DELEVAN 9406-24 7.5 x 8.9 MM  
 2. LAST USED NO. 5.  
 Δ 6710  
 Δ 6715  
 Δ 6716  
 Δ 6717  
 Δ 6718  
 Δ 6719  
 Δ 6720  
 Δ 6721  
 Δ 6722  
 Δ 6723  
 Δ 6724  
 Δ 6725  
 Δ 6726  
 Δ 6727  
 Δ 6728  
 Δ 6729  
 Δ 6730  
 Δ 6731  
 Δ 6732  
 Δ 6733  
 Δ 6734  
 Δ 6735  
 Δ 6736  
 Δ 6737  
 Δ 6738  
 Δ 6739  
 Δ 6740  
 Δ 6741  
 Δ 6742  
 Δ 6743  
 Δ 6744  
 Δ 6745  
 Δ 6746  
 Δ 6747

ARTWORK 2-23-0081C  
 PARTS LIST 1-23-04E2

RESISTOR S.A.T.

23-04E2	FWAM 1000A	23-04B1	SCHEMATIC
NEXT ASSY	QTY	MODEL	ITEM REQ'D
APPLICATION		LIST OF MATERIALS	
TOLERANCES UNLESS OTHERWISE SPECIFIED		DRAWN DATE	
ALL DIMENSIONS APPLY AFTER FINISH		550 11-2	
DECIMALS: .01 - .010 .025 - .050		CHECKED DATE	
FRACTIONS: 1/16 1/8 3/16 1/4 3/8 1/2 5/8 3/4 7/8		7/8 11-6-52	
SURFACE ROUGHNESS REMOVE ALL BURRS		APPROVED DATE	
		9/8 11-6-75	
MATERIAL		SIZE	PART NUMBER
		C	2-23-04E1
TREATMENT		SCALE	WEIGHT
FINISH			SHEET 1 OF 1



DATE	REV	CHANGE	APPRO
9-1-77	D	ORIGINAL RELEASE TJT	
1-5-78	E	INC ECN # 2954	
1-6-77	F	ADDED CONN. DES. & COAX ROS. TO CONNECTORS. TenEyck	
3-7-78	F	INC ECN 2824, 2801, 2870	
5-5-78	G	INC ECN 2954 & 2999 TenEyck	

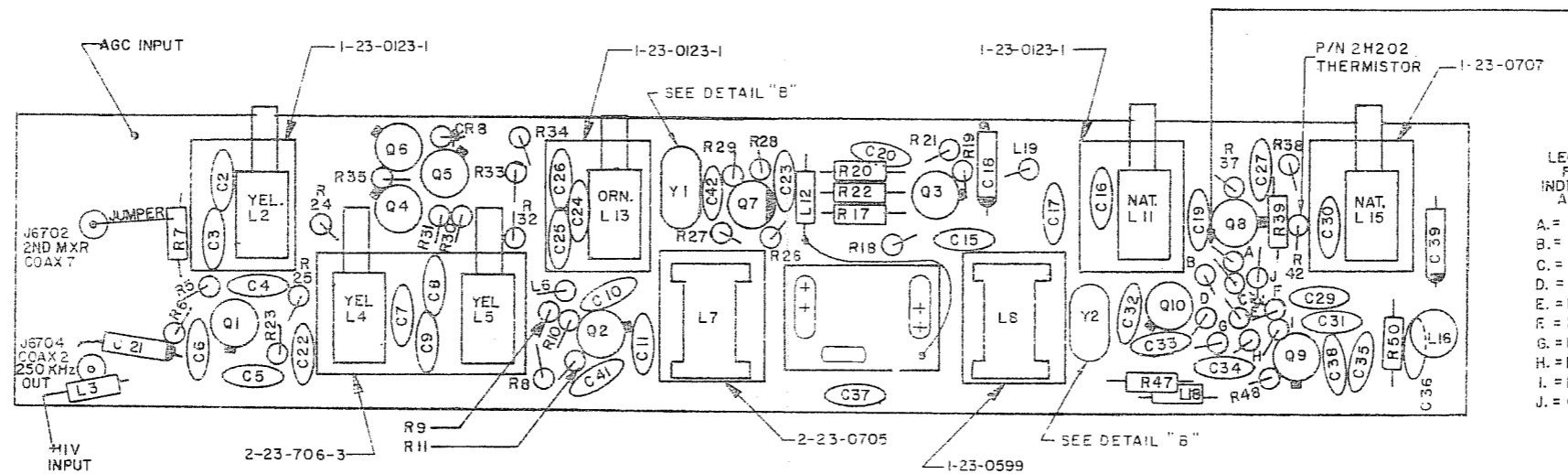
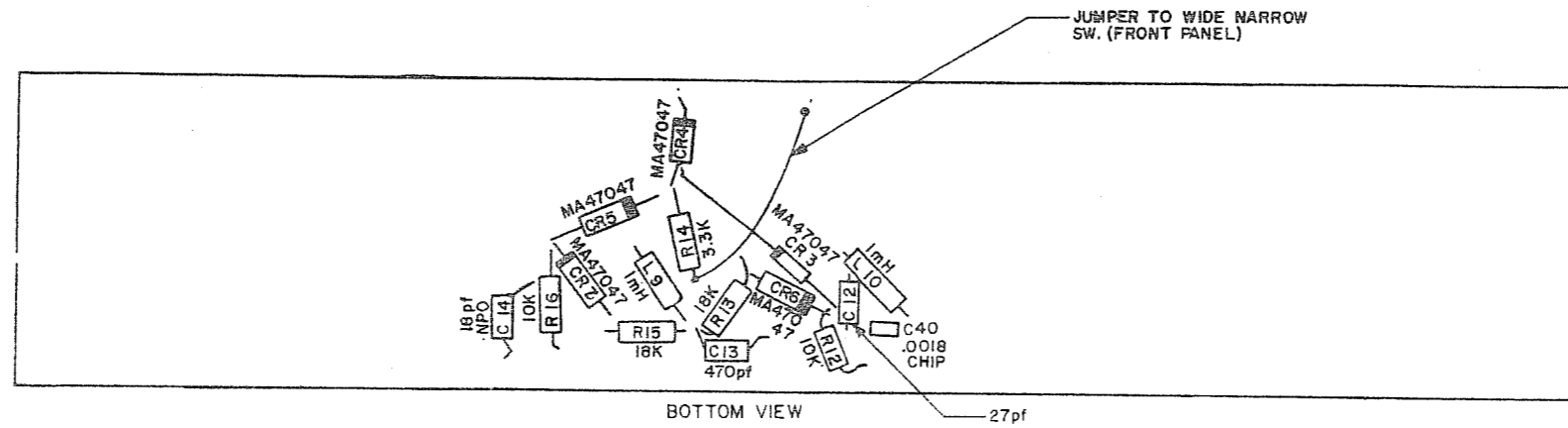

LEGEND FOR INDICATED AREA

A. = R 41  
 B. = L 14  
 C. = R 40  
 D. = R 45  
 E. = L 17  
 F. = R 44  
 G. = R 46  
 H. = R 43  
 I. = R 49  
 J. = C 28

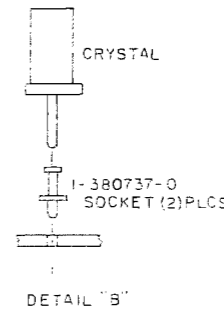
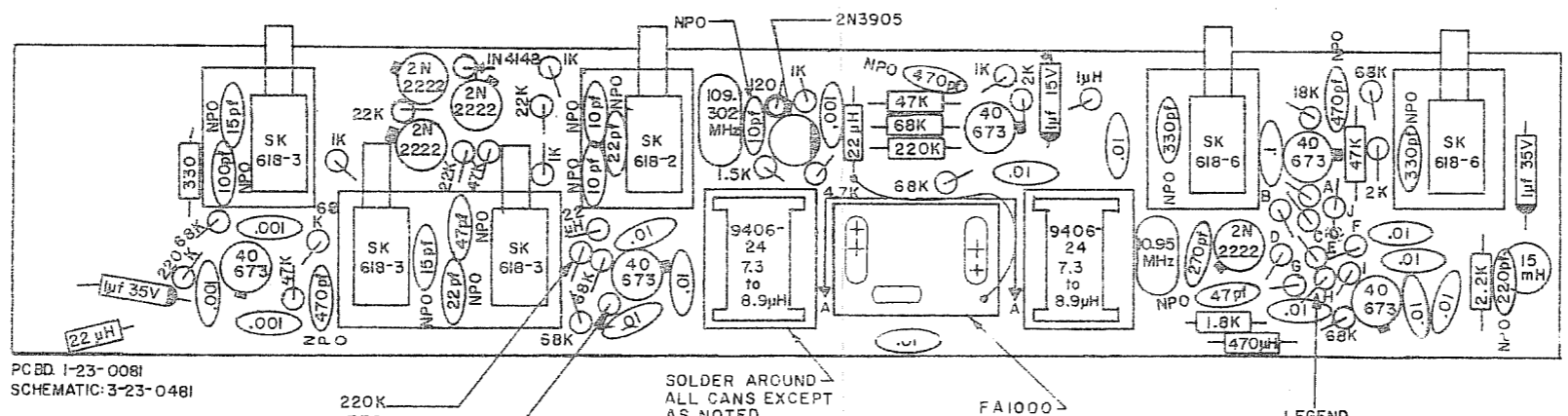

LEGEND FOR ABOVE AREA

A. = 68K  
 B. = 22μH  
 C. = 220K  
 D. = 150K  
 E. = 1mH  
 F. = 220K  
 G. = 47K  
 H. = 68K  
 I. = 330  
 J. = 1μF 35V

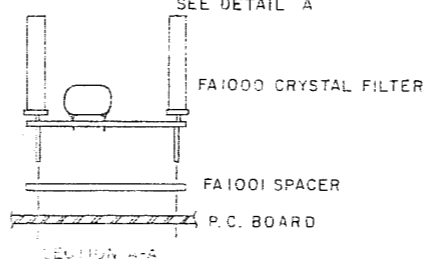

- NOTES:
1. ALL RESISTORS ARE 1/4 W, 10% TOLERANCE EXCEPT AS NOTED.
  2. ALL CAPACITOR VALUES ARE IN μF EXCEPT AS NOTED.
  3. COMPONENT LEADS MAY EXTEND .04 TO .06 BEYOND BOTTOM OF BOARD AFTER SOLDERING.
  4. MAXIMUM HEIGHT OF COMPONENTS TO BE .65 FROM COMPONENT SIDE OF BOARD AND .11 FROM BOTTOMSIDE OF BOARD.
  5. PLACE CHIP CAPACITORS ON BACK SIDE OF BOARD.
  6. ALL COMPONENT DESIGNATORS HAVE 67 PREFIX; i.e. R6701, Q6701 etc.

ITEM	REQD	PART NO	DESCRIPTION

REV. NO. 1 REV. DATE 1/2/77 NEXT ASSY QTY MODEL	TOLERANCES UNLESS OTHERWISE SPECIFIED ALL DIMENSIONS APPLY AFTER FINISH DECIMALS: .XX - ± .010 XXX - ± .005	DATE 9/28/77	TITLE
	ANGLES: 1/16 FRACTIONS: 1/16 SURFACE ROUGHNESS 125 REMOVE ALL BURRS	CHECKED	DATE
APPLICATION	APPROVED DATE	- IFR INC - WICHITA, KANSAS	
23-0483	MATERIAL	120MHz RECEIVER PC BOARD ASSEMBLY	
FINISH	SIZE C	3-23-0482	REF 6
	SCALE 2:1	WEIGHT	SHEET 1 OF 1

DATE	REV.	CHANGE	APP.
2-16-77	A	INC ECN 1884	
B-2-77	B	INC ECN 2125 A A	
4/15/77	C	INCORP ECN # 2373	
7/1/77	D	INCORP ECN # 2531 L E	
3/1/78	E	INC ECN 2705, 2788, 2855 J A	

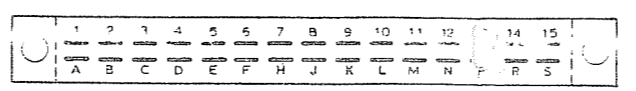
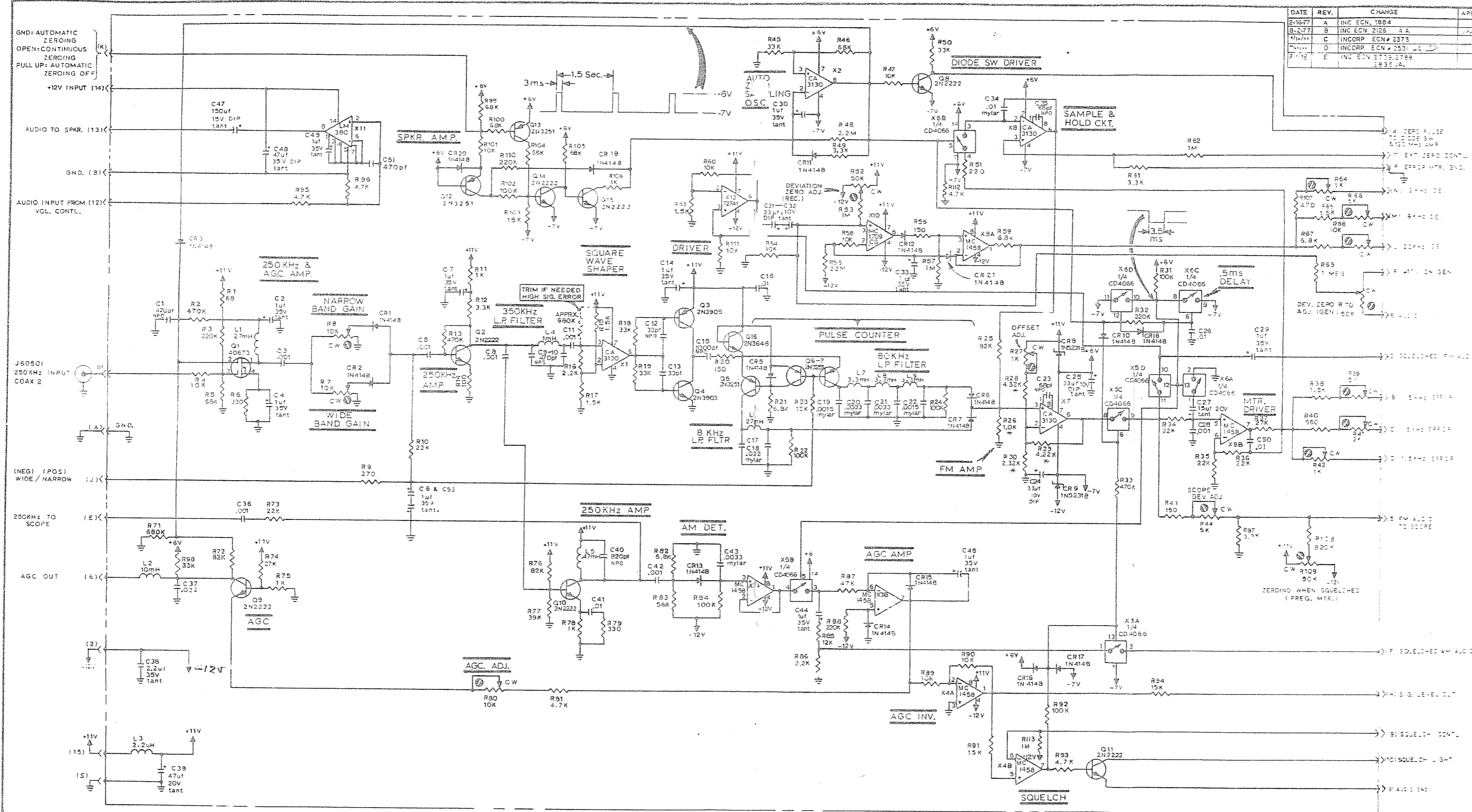

- ALL RES. IN  $\Omega$  1/8 W  
\* NOTED ARE 1/4 1/4 W
- CAPS. IN  $\mu$  UNLESS OTHERWISE NOTED
- LAST NUMBERS USED R113, C52, CR21, Q16, L9, TH1, X12
- NOS. NOT USED. C45, CR4
- "SM" CAPACITORS ARE "NPO" TYPE ON SOME UNITS

INSTRUMENT FLIGHT RESEARCH CORP. 4053 Ravenna Lane Wichita, KS	
250 KHz IF-MON. AUDIO BOARD (SCHEMATIC)	
DATE: 4-23-0605	REV: E-1-78
FMAM1000A1 SET 1 of 1	

DATE	REV	CHANGE	APPD
5/15/77	B	ORIGINAL RELEASE	MM
	C	INCRP ECN # 2573, 2447	MM
	D	INC ECN # 2519 & 2551	MM
	E	INC ECN # 2721	

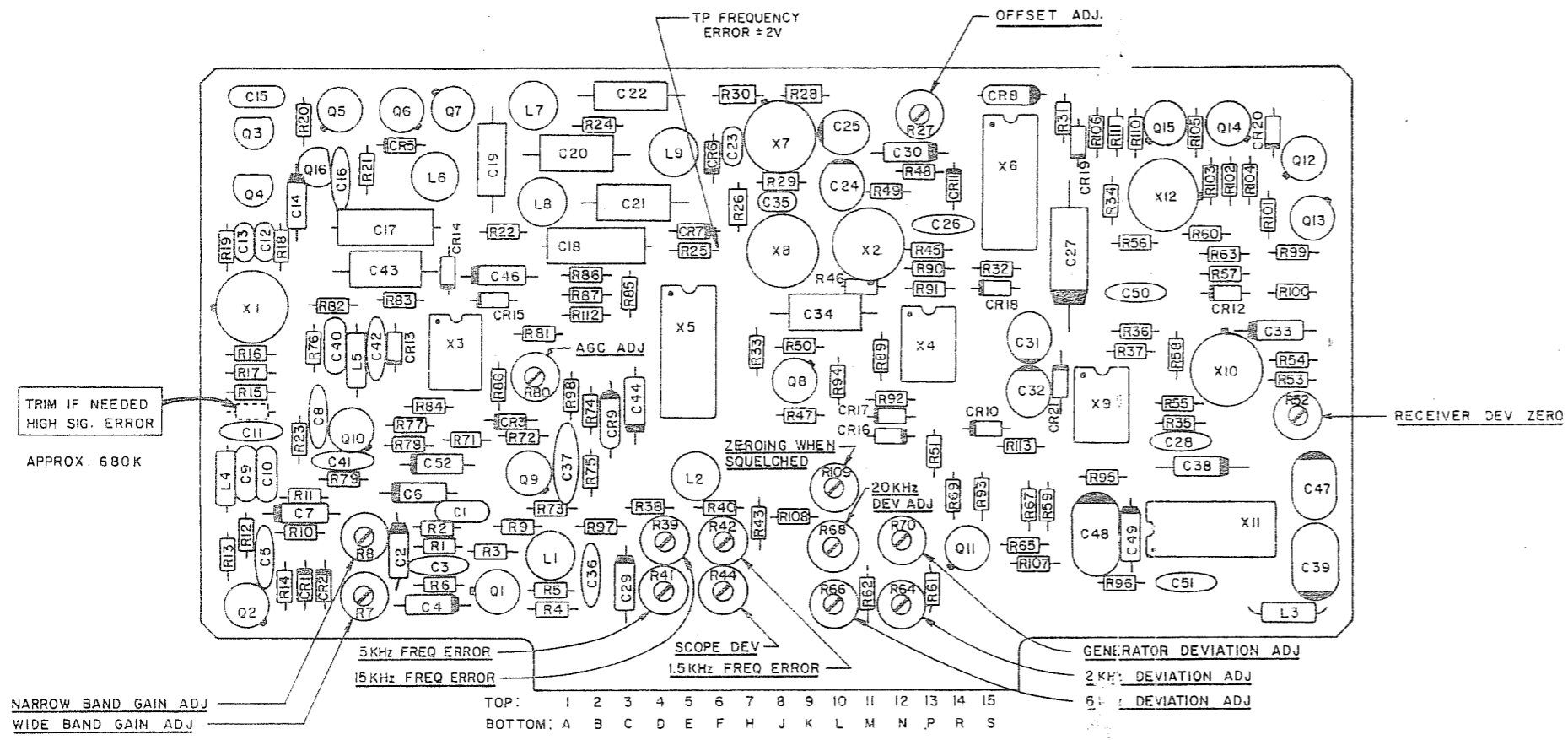

PC BOARD # 2-23-0572  
SCHEMATIC # 4-23-0605

IN #	FUNCTION	PIN #	FUNCTION
15	+11 V	S	GROUND
14	+12 V INPUT	R	+11 V ON GEN
13	AUDIO TO SPEAKER	P	ERROR MTR GND
12	AUDIO INPUT FROM VOL CONTRL	N	2 KHz DEVIATION
11	EXT ZERO CONTROL	M	6 KHz DEVIATION
10	SQUELCH LIGHT	L	20 KHz DEVIATION
9	SQUELCH CONTROL	K	GND= AUTOMATIC ZEROING OPEN= CONTINUOUS ZEROING PULL UP= AUTO ZEROING OFF
8	AUDIO GROUND	J	(NEG) (POS) WIDE BAND NARROW
7	NC	H	SIG LEVEL OUT
6	AGC OUT	F	SQUELCHED AM AUDIO
5	FM AUDIO TO SCOPE	E	250 KHz TO SCOPE
4	ZERO PULSE TO DIODE SW & 1200 MHz AMP	D	1.5 KHz ERROR
3	SQUELCHED FM AUDIO	C	5 KHz ERROR
2	-12 V	B	15 KHz ERROR
1	250 KHz INPUT	A	GROUND

ITEM	REQD	PART NO	DESCRIPTION
LIST OF MATERIALS			
TOLERANCES UNLESS OTHERWISE SPECIFIED ALL DIMENSIONS APPLY AFTER FINISH DECIMALS: .25 = 2 9/10 .001 = 1/1000 FRACTIONS: 1/64 1/32 1/16 SURFACE ROUGHNESS REMOVE ALL BURRS		DRAWN DATE R.M. 2/4/76	
MATERIAL		CHECKED DATE	
FINISH		APPROVED DATE	
SHEET 1 OF 3		TITLE 250 KHz FM AUDIO BOARD ASSEMBLY Dwg	
SCALE 2:1		PART NUMBER 2-23-0572	
WEIGHT		REV	

DATE	REV	CHANGE	APPD
2-16-77	A	INCORP ECN#1943	WJ
5-4-77	B	INCORP ECN#2013 T.T	WJ
7/27/77	C	INCORP. ECN# 2193	WJ
9/24/77	D	INCORP ECN # 2316	WJ
11/17/77	E	INC ECN 2624	WJ
11/17/77	F	INC. ECN # 2647	WJ
11/17/77	G	INC. ECN # 2869	WJ

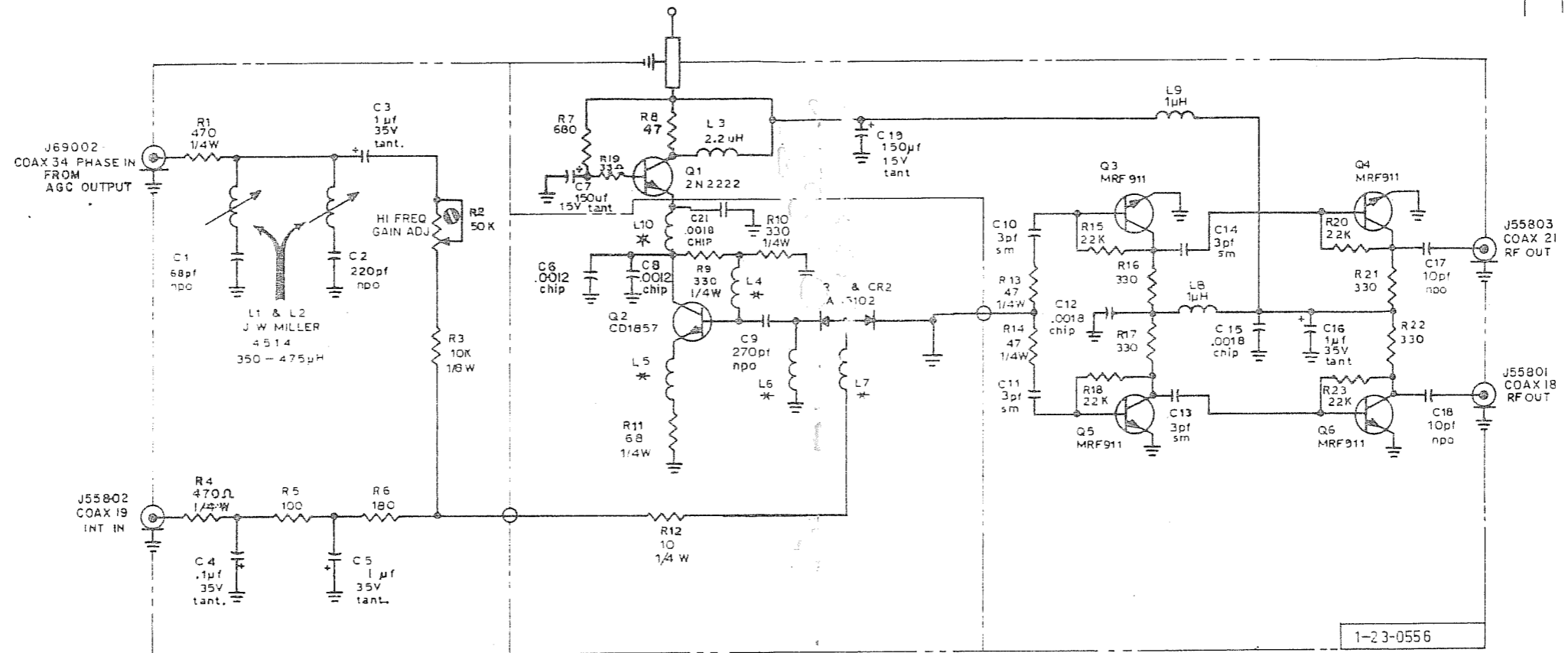

\* L5, L6, L7, L10 ARE 1-23-0597

- NOTES:
1. ALL RESISTORS ARE 1/8W 10% EXCEPT AS SHOWN.
  2. ALL RESISTANCES ARE IN OHMS EXCEPT AS SHOWN.
  3. ALL CAPACITANCES ARE IN MICROFARADS EXCEPT AS SHOWN.

LAST USED NO'S.
C21
C42
L8
Q8
R25

ITEM	QTY	PART NO.	DESCRIPTION
LIST OF MATERIALS			
- IFR INC - MOBILE, KANSAS			
100-2200MHZ OSC., BUFFER, TUNE SUMMATION SCHEMATIC			
1-23-0556			



DATE	REV	CHANGE	APP'D
1-19-76	A	INC. ECN NO. 2717 A.A. <i>SWP</i>	WW
3-9-76	B	INC ECN 2819 2709 JAJ <i>BJD</i>	WW
4-10-76	C	INC ECN 2912 <i>Joe D</i>	WW

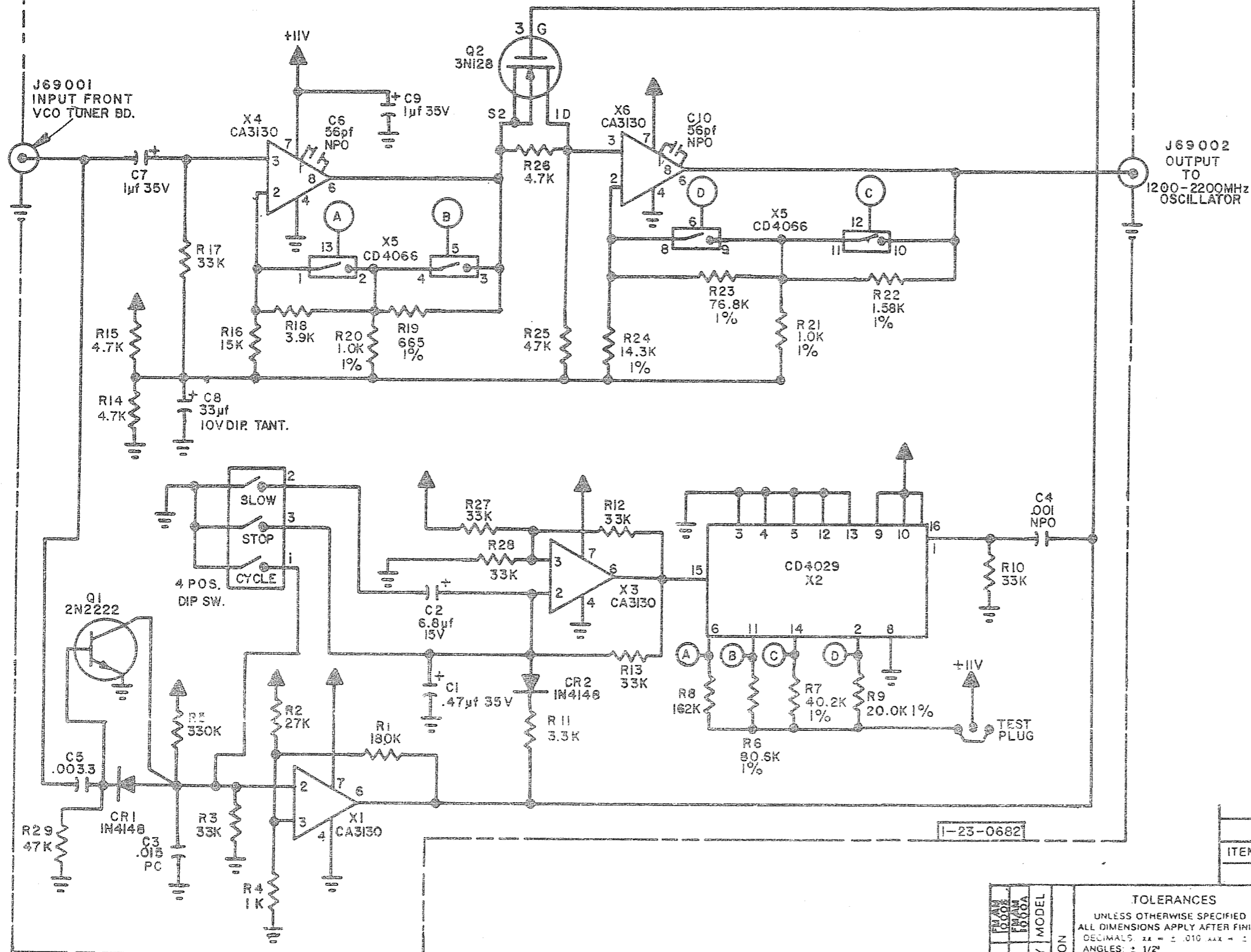

J69002  
OUTPUT  
TO  
1200-2200MHz  
OSCILLATOR

EFFECTIVE: 1000A S/N882 & ON  
1000S S/N170 & ON

- NOTES:
- ALL RESISTORS ARE 1/4W 10% TOL & VALUES ARE IN OHMS UNLESS OTHERWISE SPECIFIED.
  - LAST NOS. USED C10, R29, X6, D2, & J2.
  - ALL CAPACITORS ARE IN  $\mu\text{f}$  EXCEPT AS NOTED.

ITEM	REQ'D	PART NO.	DESCRIPTION
LIST OF MATERIALS			
			- IFR INC - WICHITA, KANSAS
			AGC SYSTEM SCHEMATIC
MATERIAL		SCALE	REV
FINISH		WEIGHT	C
		SHEET	OF 1

REV	DATE	BY	CHKD	DATE	APP'D	DATE
1	11-29-77	TenEyck				
2	11-29-77					
3	12-10-77					

TOLERANCES  
UNLESS OTHERWISE SPECIFIED  
ALL DIMENSIONS APPLY AFTER FINISH  
DECIMALS: .xx = ± .010 MAX - ± .005  
ANGLES: ± 1/2°  
FRACTIONS: ± 1/64  
SURFACE ROUGHNESS 125  
REMOVE ALL BURRS

DATE	REV	CHANGE	APP'D
4-12-78	A	INC ECN 2912	

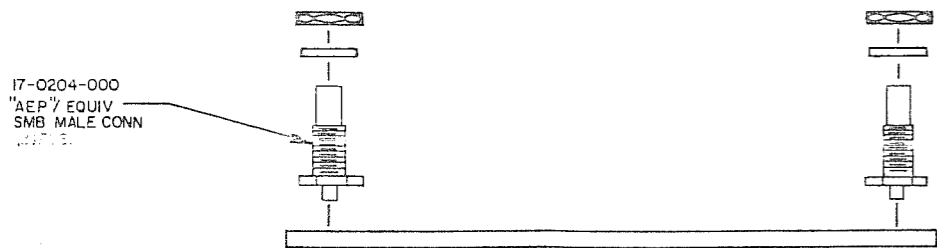
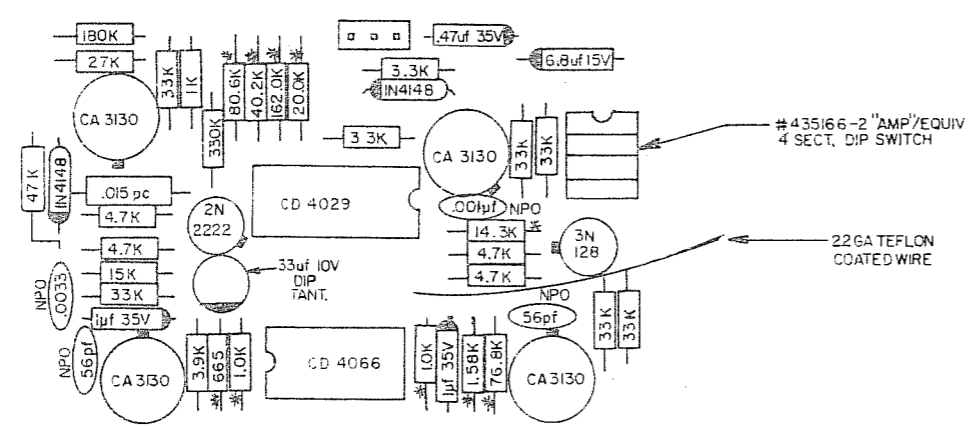
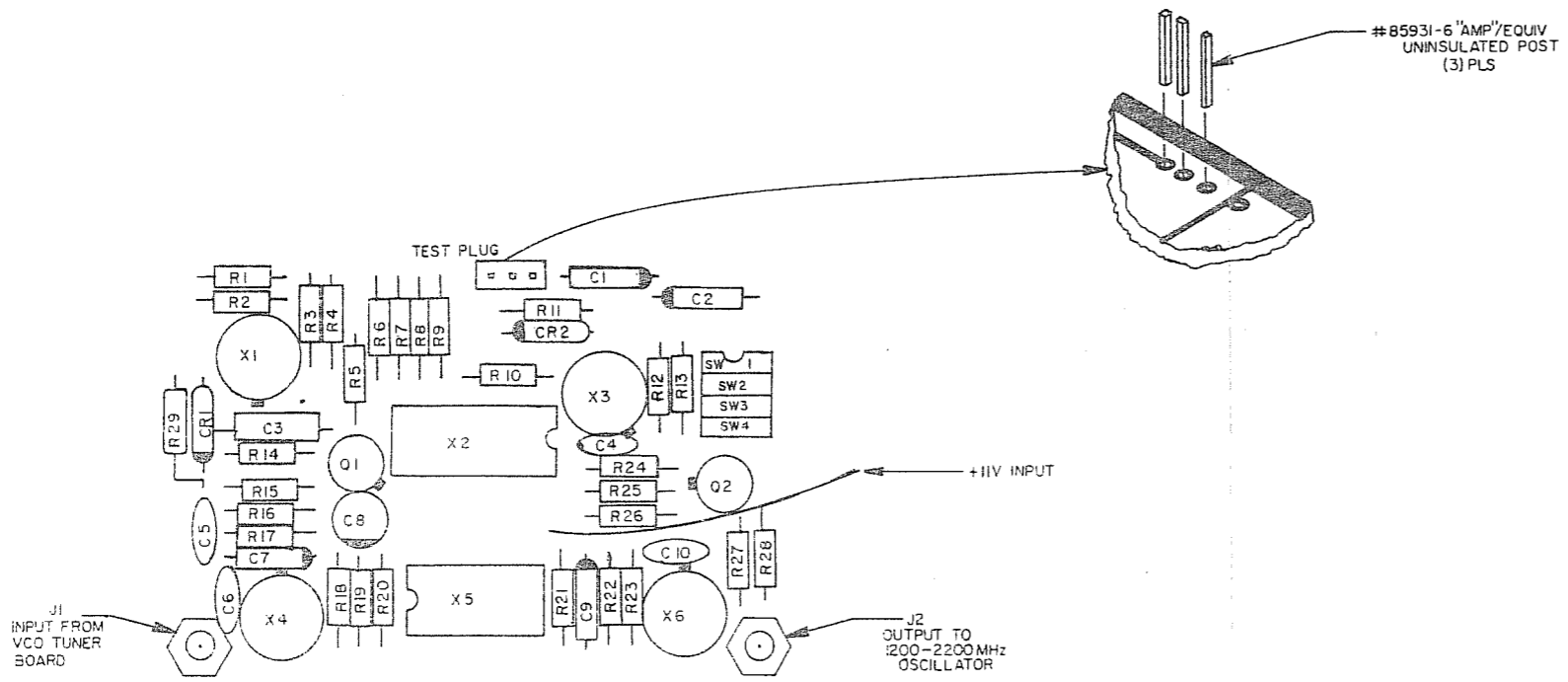

7. SCHEMATIC NO. 2-23-0690
6. PC BOARD NO. 1-23-0682
5. COMPONENT LEADS MAY EXTEND .04 TO .06 BEYOND BOTTOM OF BOARD AFTER SOLDERING.
4. MAX. HEIGHT OF COMPONENTS TO BE .37 FROM COMPONENT SIDE OF BOARD.
3. ALL CAPACITORS ARE IN  $\mu$ F EXCEPT AS NOTED.
2.  $\frac{1}{2}$  DENOTES 1/4W, 1% TOL. RESISTORS.
1. ALL RESISTORS ARE 1/4W, 10% TOL. EXCEPT AS NOTED.

EFFECTIVE: FM/AM1000A S/N 882 & ON  
FM/AM1000S S/N 170 & ON

ITEM	REQ'D	PART NO.	DESCRIPTION
LIST OF MATERIALS			

23-0216	1	1000A	1	1000A	1	1000A	1	1000A	1
23-0644	1	1000B	1	1000B	1	1000B	1	1000B	1
APPLICATION									
MATERIAL					FINISH				
TOLERANCES					DRAWN DATE				
UNLESS OTHERWISE SPECIFIED					TenEyck 11-28				
ALL DIMENSIONS APPLY AFTER FINISH					CHECKED DATE				
DECIMALS: .25 = ±.010 .125 = ±.005					APPROVED DATE				
ANGLES: 1/2"					TITLE				
FRACTIONS: 1/16"					- IFR INC -				
SURFACE ROUGHNESS 125					WICHITA, KANSAS				
REMOVE ALL BURRS					AGC SYSTEM				
					PC BOARD				
					ASSEMBLY				
					SIZE		PART NUMBER		REV
					C		3-23-0686		A
					SCALE		WEIGHT		SHEET 1 OF 1
					2=1				





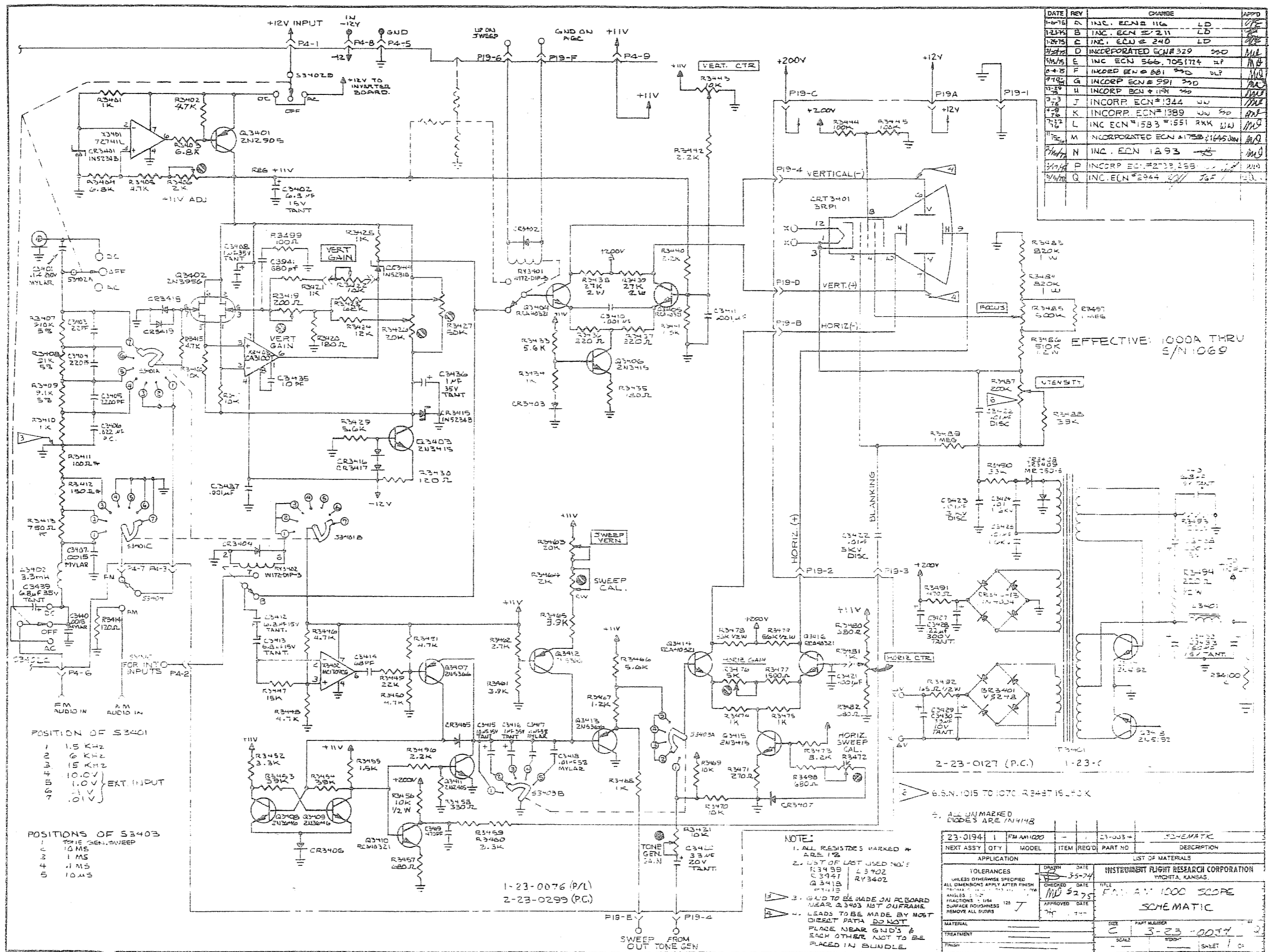

DATE	REV	CHANGE	APPRO
1-23-76	A	INC. ECN# 116	LD
1-23-76	B	INC. ECN# 211	LD
1-23-76	C	INC. ECN# 240	LD
1-23-76	D	INCORPORATED ECN# 329	SSD
1-23-76	E	INC ECN 566, 1051724	HP
1-23-76	F	INCORP ECN# 881	DLP
1-23-76	G	INCORP ECN# 991	SSD
1-23-76	H	INCORP ECN# 1151	SSD
1-23-76	J	INCORP. ECN# 1344	SSD
1-23-76	K	INCORP. ECN# 1389	SSD
1-23-76	L	INC ECN# 1583, 1551	RKK
1-23-76	M	INCORPORATED ECN# 1758, 1645	SSD
1-23-76	N	INC. ECN 1893	SSD
1-23-76	P	INCORP ECN# 2138, 2139	SSD
1-23-76	Q	INC. ECN# 2944	SSD

- POSITION OF S3401
- 1 1.5 KHZ
  - 2 3 KHZ
  - 3 15 KHZ
  - 4 10.0V
  - 5 1.0V
  - 6 0.1V
- EXT. INPUT
- POSITIONS OF S3403
- 1 10 MS
  - 2 1 MS
  - 3 1 MS
  - 4 1 MS
  - 5 10 MS

1-23-0076 (P/L)  
2-23-0299 (P.C.)

NOTE:

- ALL RESISTORS MARKED \* ARE 1%.
- LIST OF LAST USED NOS: R3499, R3402, R3413, R3402.
- WELD TO BE MADE ON REBOARD NEAR Q3403 NOT OUTFRAME.
- LEADS TO BE MADE BY MOST DIRECT PATH DO NOT PLACE NEAR GND'S & EACH OTHER NOT TO BE PLACED IN BUNDLE.

23-0194	1	FM AM 1000	-	23-003+	SCHEMATIC
NEXT ASSY	QTY	MODEL	ITEM	REQ'D	PART NO
APPLICATION					
TOLERANCES UNLESS OTHERWISE SPECIFIED					
ALL DIMENSIONS APPLY AFTER FINISH					
ANGLES: 1/2					
FRACTIONS: 1/16					
SURFACE FINISH: 125					
REMOVE ALL BURRS					
MATERIAL					
TREATMENT					
FINISH					
LIST OF MATERIALS					
INSTRUMENT FLIGHT RESEARCH CORPORATION					
WICHITA, KANSAS					
DATE: 3-5-74					
TITLE: FM AM 1000 SCOPE					
SCHEMATIC					
SIZE: 3-23-0074					
SCALE: 100%					
SHEET 1 OF 1					

EFFECTIVE: 1000A THRU 5/N1060

2-23-0127 (P.C.) 1-23-0

G.S.N. 1015 TO 1070 R3487 16.40K

ALL UNMARKED DIODES ARE 1N4148

DATE	REV	CHANGE	APPRO

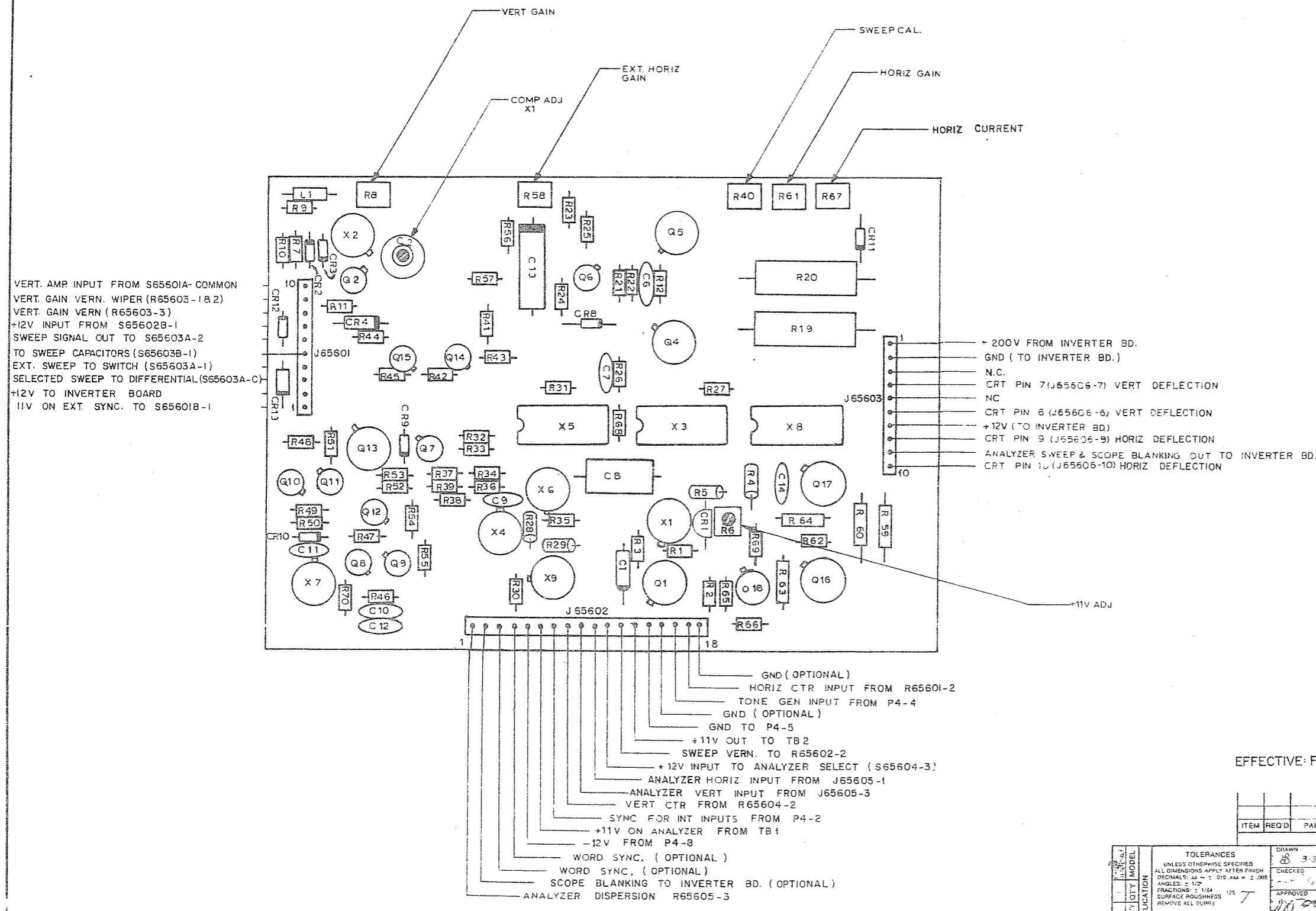

VERT. AMP INPUT FROM S65601A-COMMON  
 VERT. GAIN VERN. WIPER (R65603-1 & 2)  
 VERT. GAIN VERN (R65603-3)  
 +12V INPUT FROM S65602B-1  
 SWEEP SIGNAL OUT TO S65603A-2  
 TO SWEEP CAPACITORS (S65603B-1)  
 EXT. SWEEP TO SWITCH (S65603A-1)  
 SELECTED SWEEP TO DIFFERENTIAL (S65603A-C)  
 +12V TO INVERTER BOARD  
 +11V ON EXT. SYNC. TO S65601B-1

EFFECTIVE: FM/AMI000A S/N 1070-8 ON

ITEM	QTY	RECD	PART NO	DESCRIPTION
LIST OF MATERIALS				
- IFR INC - WICHITA, KANSAS				
TITLE: SCOPE MAIN BOARD ASS'Y DWG				
MATERIAL		PART NUMBER		REV
		C 3-23-0625		1
FINISH		SCALE		WEIGHT
				SHEET 2 OF 2



DATE	REV	CHANGE	APP
7-2-78	A	INC ECN 2712	W
7-2-78	A	INC ECN 2788 A.A.	W
7-2-78	A	INC ECN 2753	W
7-2-78	B	INC ECN 3058 T.T.	W

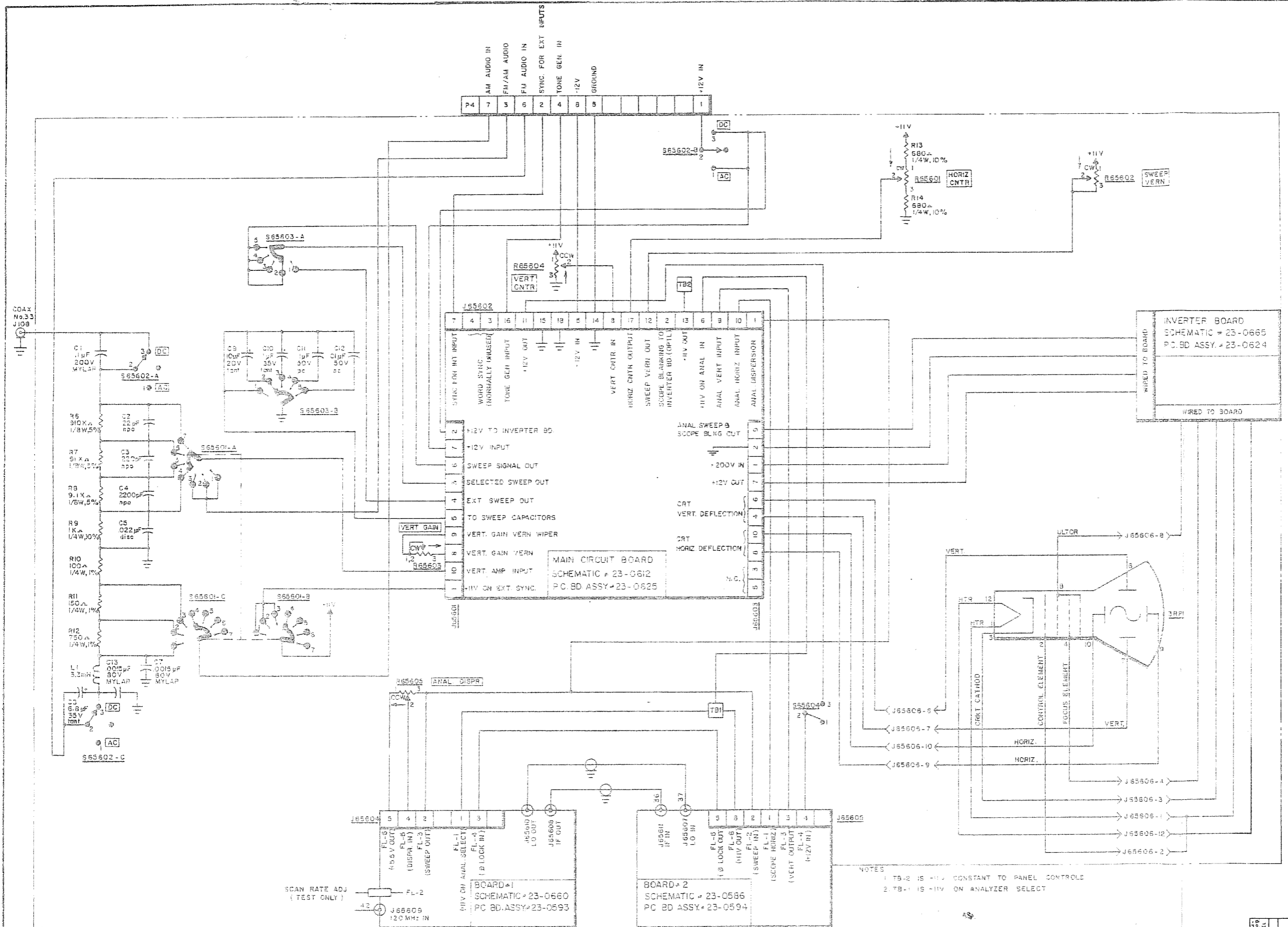

NOTES  
 1 TB-2 IS -1V CONSTANT TO PANEL CONTROLS  
 2 TB-1 IS -1V ON ANALYZER SELECT

ITEM	REQD	PART NO	DESCRIPTION
23-0666 SPECT. ANAL. INTERCONNECT			
LIST OF MATERIALS			

APPROVED	DATE	APPROVED	DATE
DRW	4/11/78	CHKD	4/11/78
APP'D	4/11/78	APP'D	4/11/78

TOLERANCES  
 UNLESS OTHERWISE SPECIFIED  
 ALL DIMENSIONS APPLY AFTER FINISH  
 DIMENSIONS IN INCHES ARE TO BE USED UNLESS OTHERWISE SPECIFIED  
 DIMENSIONS IN MILLIMETERS ARE TO BE USED UNLESS OTHERWISE SPECIFIED  
 SURFACE FINISH SHALL BE AS SPECIFIED  
 REMOVE ALL BURRS

MATERIAL: \_\_\_\_\_  
 QUANTITY: \_\_\_\_\_  
 PART NUMBER: 4-23-0666  
 SHEET 1 OF 1



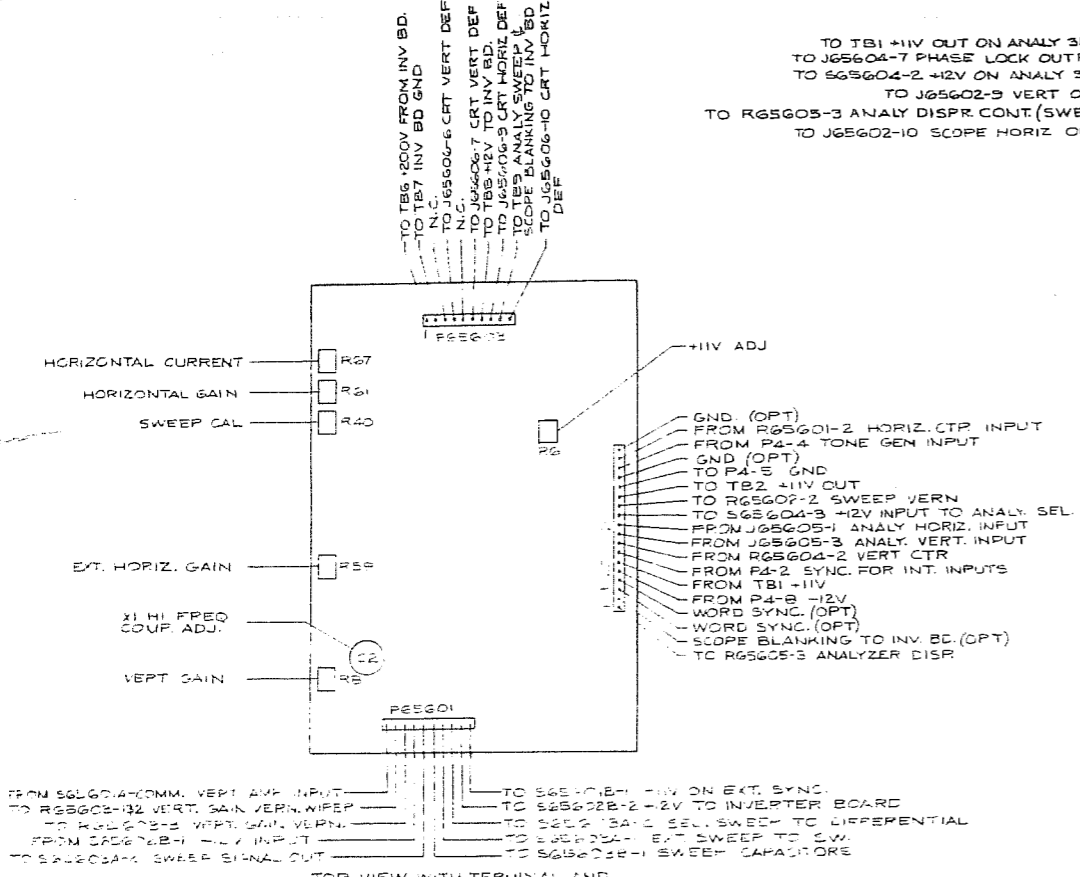

TOP VIEW WITH TERMINAL AND ADJUSTMENT POINT IDENTIFICATION MAIN BOARD  
1-23-0625  
BOTTOM VIEW WITH COMPONENT IDENTIFICATION

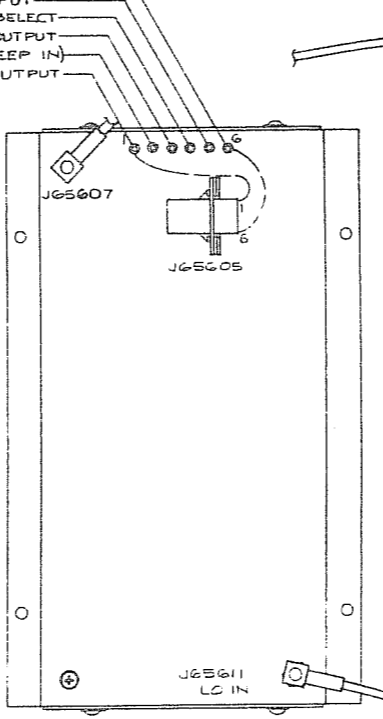
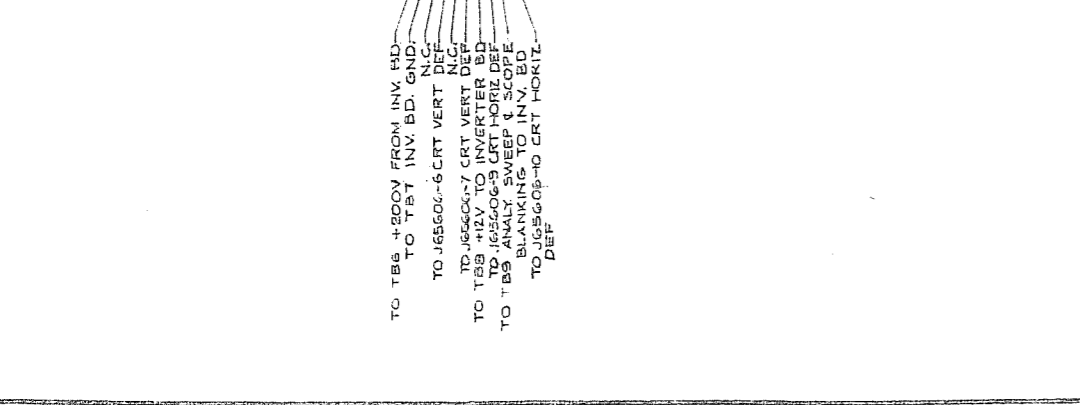
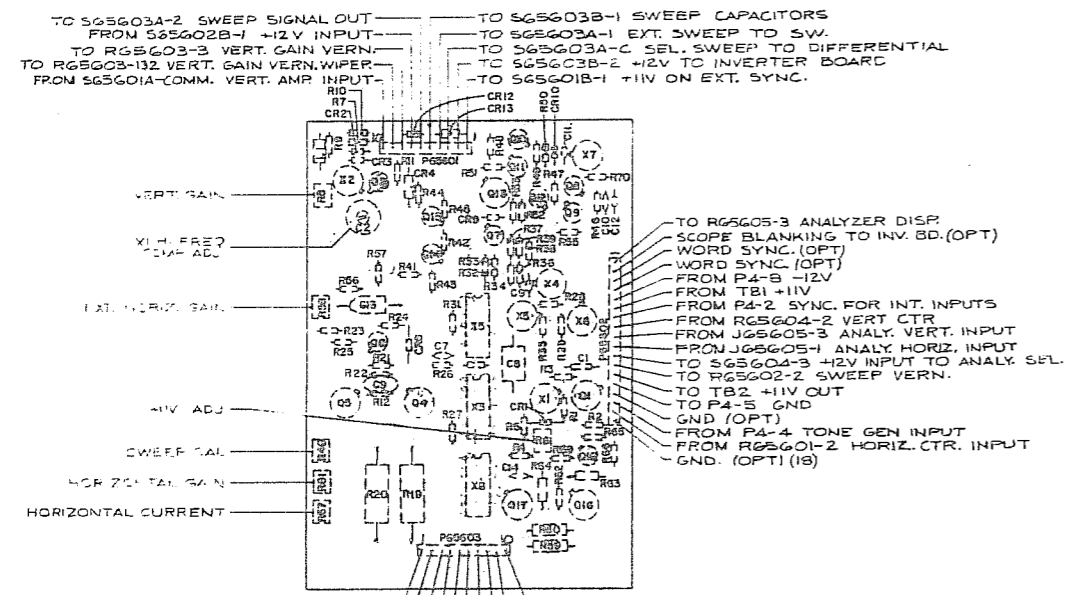

TOP VIEW  
MODULE #2  
1-23-0633  
BOTTOM VIEW

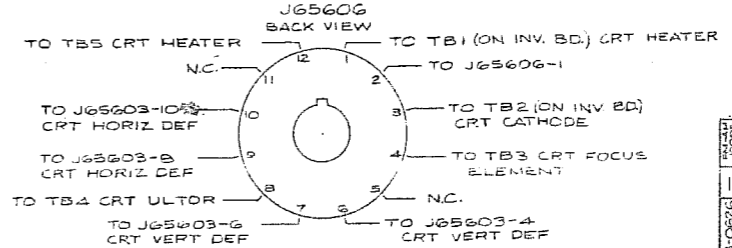
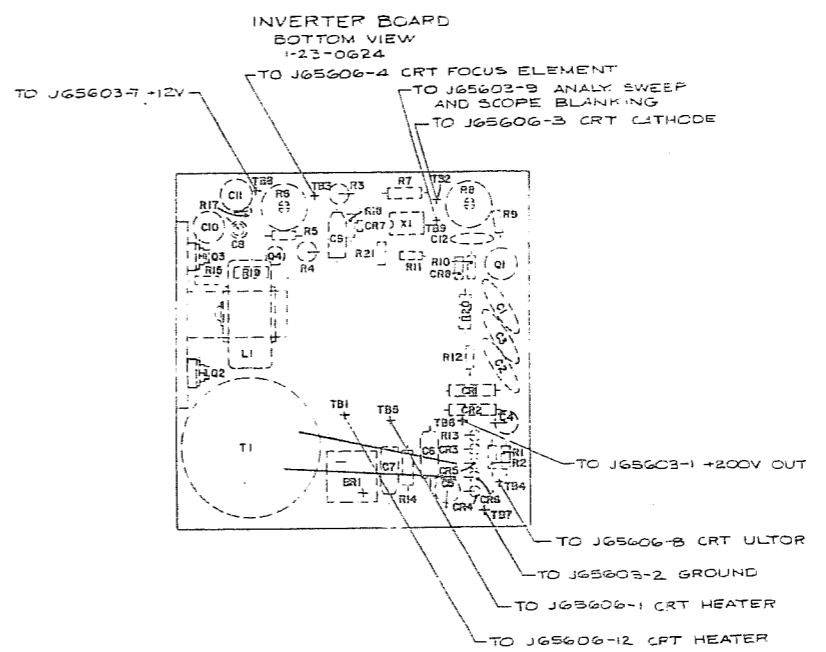
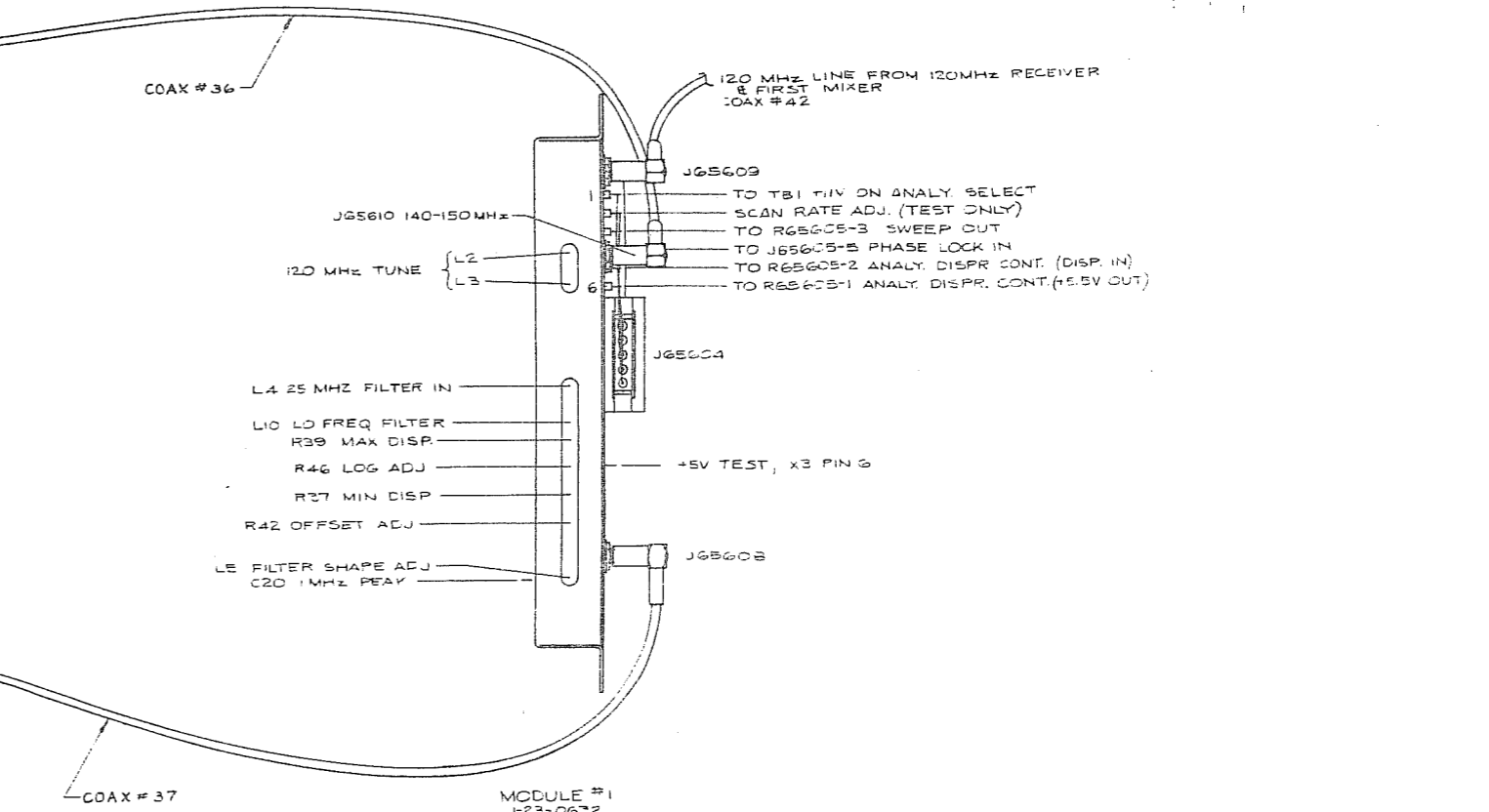
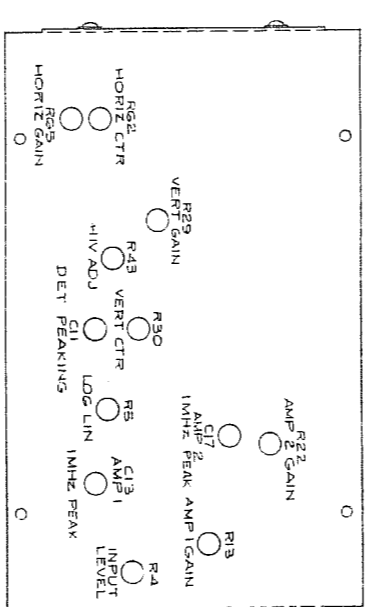

ITEM	REV	PART NO	DESCRIPTION
			LIST OF MATERIALS
			IFR INC - WICHITA, KANSAS
			SPECTRUM ANALYZER TEST INTERCONNECT
			23-0626
			Sheet 1 of 1



8/21/72	D	REVISED & REDRAWN L/C	CP	
7/23/72	E	INCORP. ECN # 2389	JUN 72	ML
7/27/72	F	INCORP. ECN # 2430	L/C	ML
7/11/72	G	INCORP. ECN # 2468	L/C	ML
7/27/72	H	INCORP. ECN # 2498 & 2525	L/C	ML
7/27/72	J-1	INC. ECN # 2727	A.A.	ML
7/27/72	J-2	INC. ECN # 2888	JAT	ML

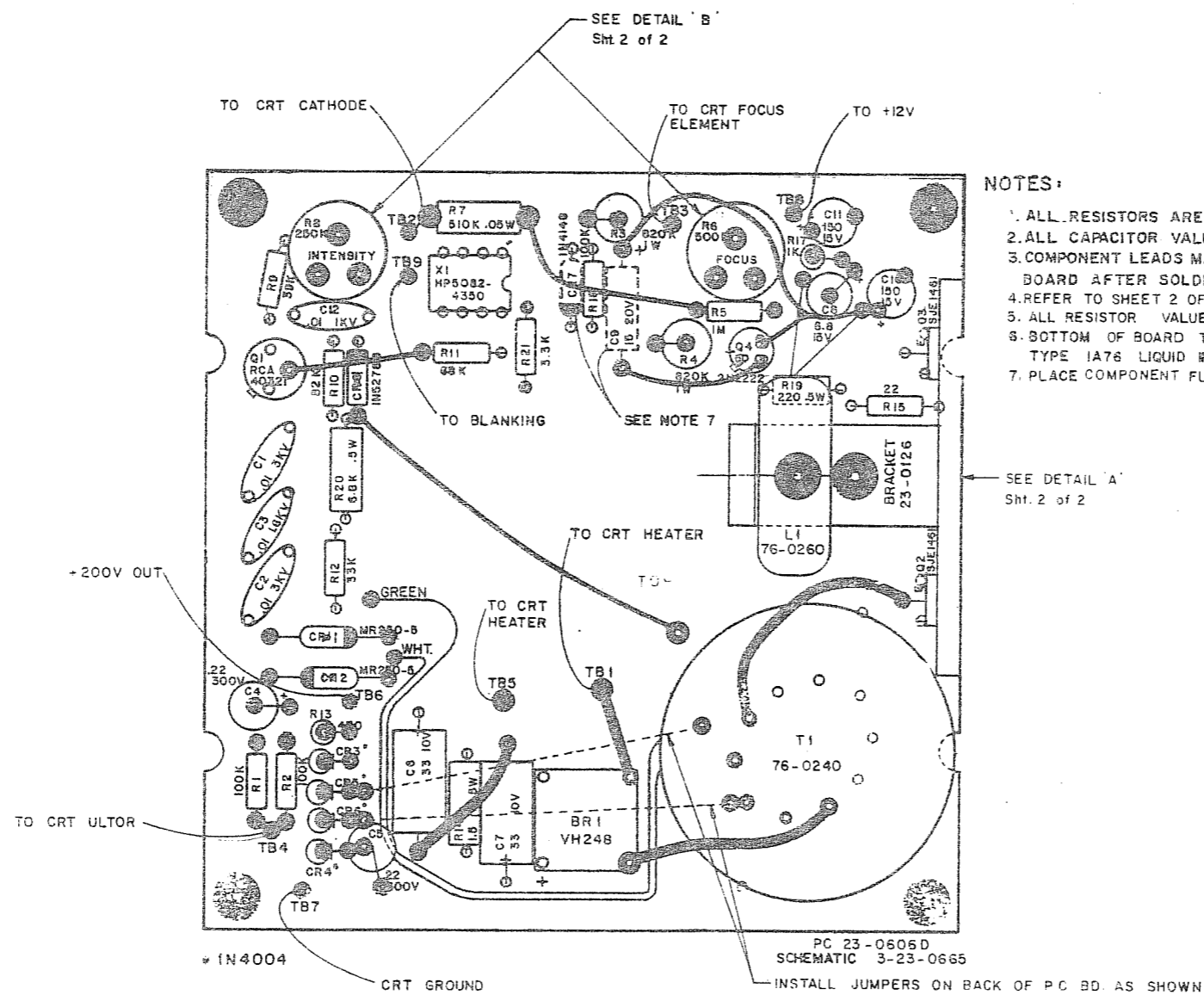

- NOTES:
1. ALL RESISTORS ARE 1/4 W., 10% TOLERANCE EXCEPT AS NOTED.
  2. ALL CAPACITOR VALUES ARE IN  $\mu$ F EXCEPT AS NOTED.
  3. COMPONENT LEADS MAY EXTEND .04 TO .06 BEYOND BOTTOM OF BOARD AFTER SOLDERING.
  4. REFER TO SHEET 2 OF 2 FOR PLUG WIRING & DETAIL INFORMATION.
  5. ALL RESISTOR VALUES ARE IN  $\Omega$  EXCEPT AS NOTED.
  6. BOTTOM OF BOARD TO BE COATED WITH "HUMISEAL" / EQUIV. TYPE 1A76 LIQUID INSULATION.
  7. PLACE COMPONENT FLAT ON BACK SIDE OF P.C. BOARD.

EFFECTIVE: FM/AM1000A S/N 1070 & ON

ITEM	REQD	PART NO	DESCRIPTION
LIST OF MATERIALS			
DRAWN DATE L/C 8/21/72			TITLE - IFR INC - WICHITA, KANSAS
CHECKED DATE ML 8/21/72			TITLE SPECT. ANAL. INVERTER PC BOARD ASSY.
APPROVED DATE ML 8/21/72			FM/AM-1000A
MATERIAL See L/M		SIZE C	PART NUMBER 3-23-0624
FINISH		SCALE 2 X	WEIGHT SHEET 1 OF 2





REV	DESCRIPTION	DATE	BY	CHKD
1	INC ECN 2039	7/74	WU	WU
2	INC ECN 2753, 2826	7/74	WU	WU
3	INC ECN 3058	7/74	WU	WU

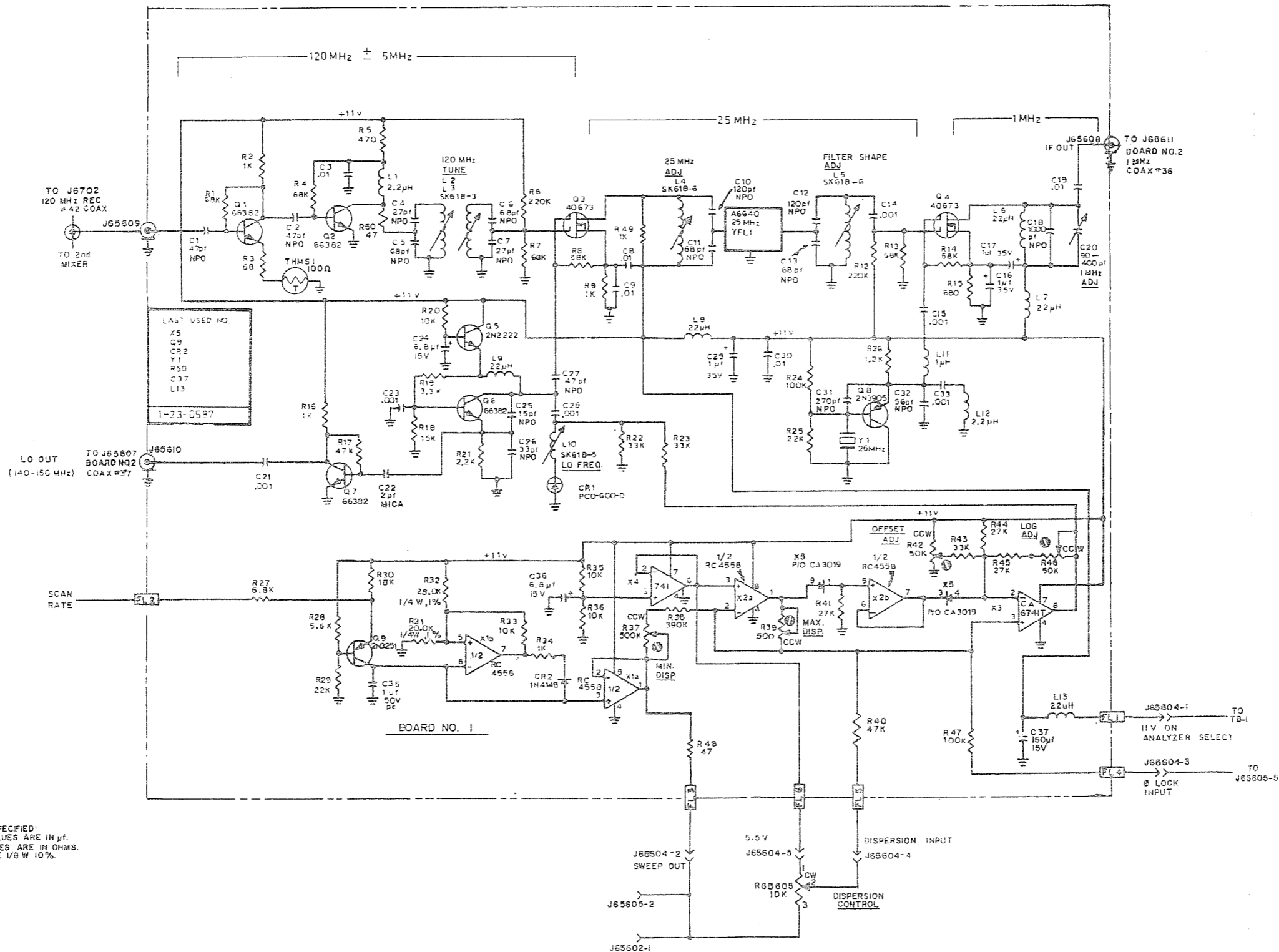

NOTES:  
 1. UNLESS OTHERWISE SPECIFIED:  
 A. ALL CAPACITOR VALUES ARE IN  $\mu$ F.  
 B. ALL RESISTOR VALUES ARE IN OHMS.  
 C. ALL RESISTORS ARE 1/8 W 10%.

ITEM	REQD	PART NO	DESCRIPTION
LIST OF MATERIALS			
- IFR 198C -			
- TROBTA, KANSAS			
SPECTRUM ANALYZER			
BOARD NO. 1 SCHEMATIC			
DATE	BY	CHKD	APP'D
7/74	WU	WU	WU
TOLERANCES		DRAWN DATE	
UNLESS OTHERWISE SPECIFIED		TJT 6-18-77	
ALL DIMENSIONS APPLY UNLESS NOTED		CHECKED DATE	
DIMENSIONS ARE IN INCHES		7/74	
DIMENSIONS ARE IN MILLIMETERS		APPROVED DATE	
DIMENSIONS ARE IN MILLIMETERS		7/20/77	
DIMENSIONS ARE IN MILLIMETERS		APPROVED DATE	
DIMENSIONS ARE IN MILLIMETERS		7/20/77	

DATE	REV	QUANTITY	APP'D
7-5-78	A	INCORP. ECH-2220 AA	[Signature]
	B	INCORP. ECH-2220 LA	[Signature]
	C	INCORP. ECH-2471-LA	[Signature]
	D	INCORP. ECH-2859, 2753, 2853	[Signature]
	E	INCORP. ECH-3058 I.T.	[Signature]

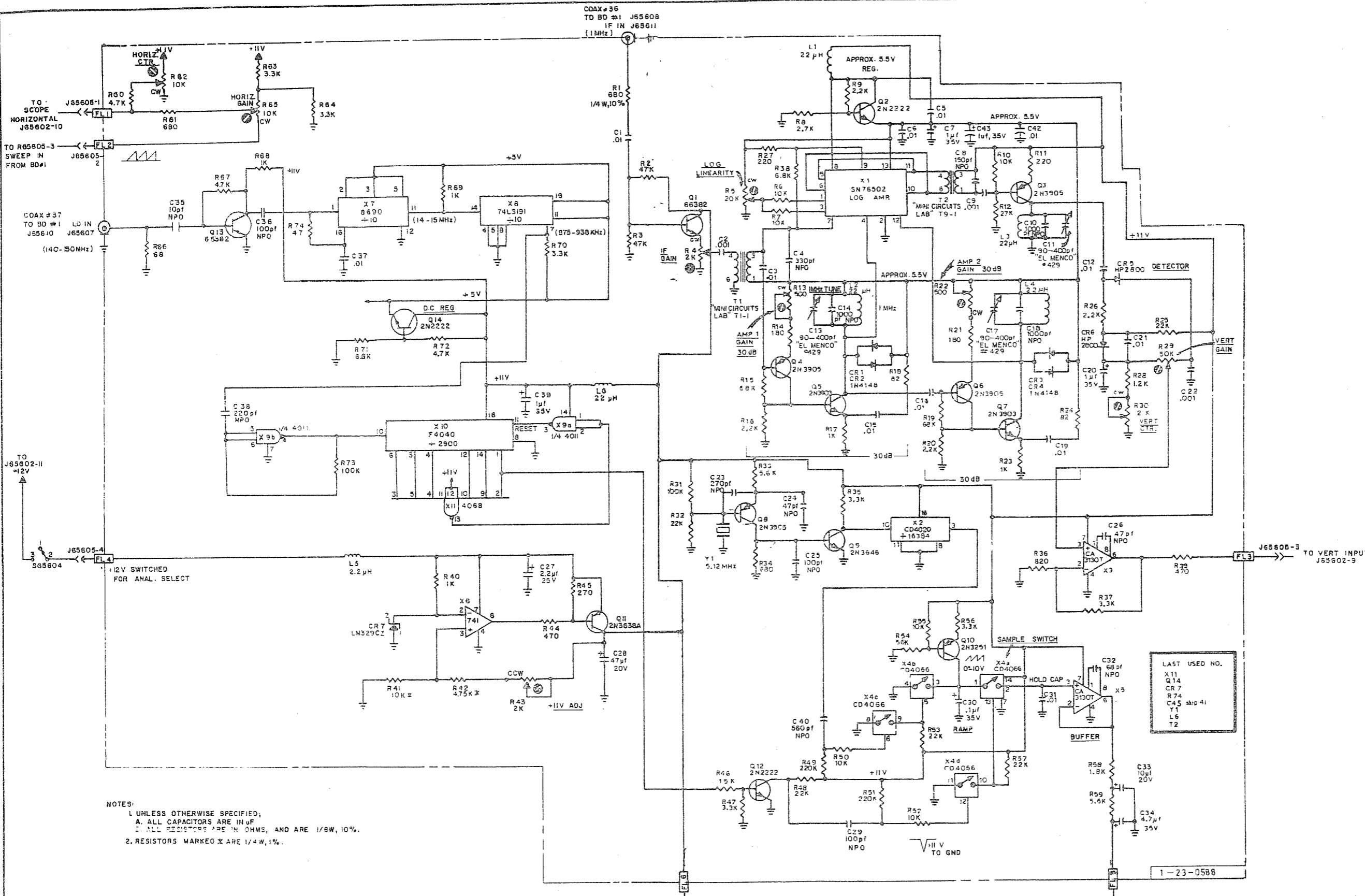

NOTES:  
 1. UNLESS OTHERWISE SPECIFIED,  
 A. ALL CAPACITORS ARE IN  $\mu$ F  
 B. ALL RESISTORS ARE IN OHMS, AND ARE 1/8W, 10%.  
 2. RESISTORS MARKED X ARE 1/4W, 1%.

LAST USED NO.  
 X11  
 Q14  
 CR7  
 R74  
 CA5  
 T1  
 L6  
 T2

1-23-0588

ITEM	REQD	PART NO	DESCRIPTION
LIST OF MATERIALS			
TOLERANCES UNLESS OTHERWISE SPECIFIED: ALL DIMENSIONS APPLY AFTER FINISH FRACTIONS - 1/16 SURFACE FINISHES REMOVE ALL BURRS			
DESIGN	DATE	- 128 19K - WORK IN PROGRESS	
TJT 6-17-77		SPECTRUM ANALYZER BOARD NO. 2 SCHEMATIC	
APPROVED	DATE	SHEET 1 OF 1	
[Signature]	7-2-77		

DATE	REV	CHANGE	APPD
2/17/77	A	INCORP ECN # 2271 LJC WJW	MW
3/1/77	B	INCORP ECN # 2365 LJC WJW	MW
3/22/77	C	INCORP ECN # 2638 2538 JAT	MW
7-8-77	C-1	INC ECN 2824 JAT	
7-8	C-2	INC ECN 3058 T.T.	

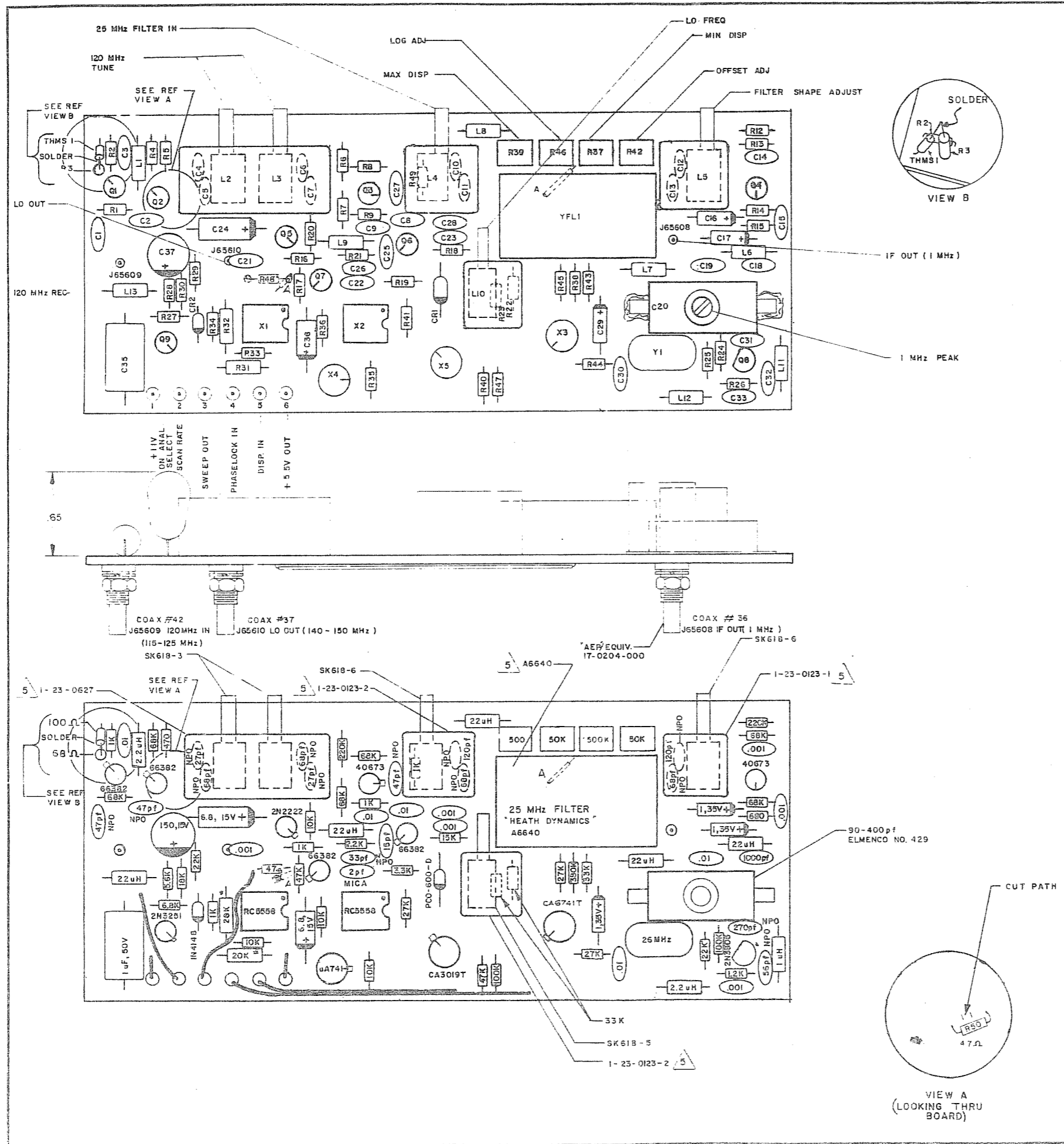

- NOTES:
1. ALL RESISTORS ARE 1/8 W., 10% TOLERANCE EXCEPT AS NOTED.
  2. ALL CAPACITOR VALUES ARE IN  $\mu$ F EXCEPT AS NOTED.
  3. COMPONENT LEADS MAY EXTEND .04 TO .06 BEYOND BOTTOM OF BOARD AFTER SOLDERING.
  4. MAXIMUM HEIGHT OF COMPONENTS TO BE .55 FROM COMPONENT SIDE OF BOARD.
  5. ALL RF SHIELDS TO BE COMPLETELY SOLDERED, ALL SIDES.
  6. ALL JUMPERS TO BE AWG 24
  7. REF DWG: SCHEMATIC 4-23-0660
  8. \* (ASTERISK) DENOTES  $\pm$  1% RESISTOR TOLERANCE 1/4 W

ITEM	REQD	PART NO.	DESCRIPTION
LIST OF MATERIALS			
1	1	3-23-0593	SPECTRUM ANALYZER PC BD ASSY
2	1	47.5	47.5

DATE	REV	APPD	TITLE
4/20/77		MW	SPECTRUM ANALYZER PC BD ASSY
5-4-77			BD NO 1
7-5-77			



DATE	REV	CHANGE	APP'D
10/1/77	A	INCRP. ECN # 2419 LC	<i>[Signature]</i>
1/3/78	B	INC. ECN # 2570 A.A.	<i>[Signature]</i>
1/17/78	C	INC ECN 2709	<i>[Signature]</i>

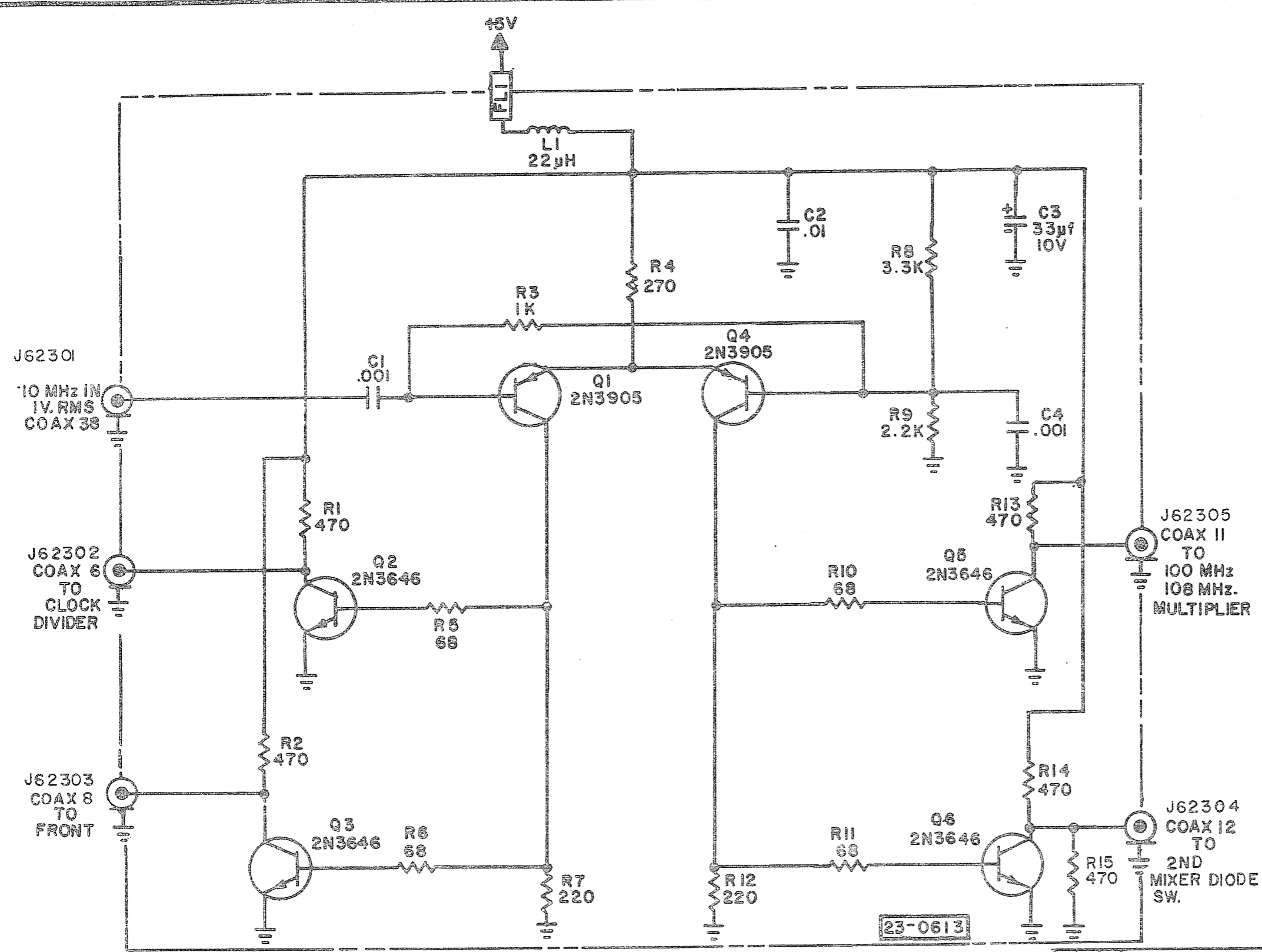

- NOTES:
1. ALL RESISTORS ARE 1/8W, 10% AND VALUES ARE IN OHMS UNLESS OTHERWISE SPECIFIED.
  2. ALL CAPACITORS ARE IN µF UNLESS OTHERWISE SPECIFIED.

LAST USED NOS.  
C4, R15, Q6, L1

23-0613

ITEM	REQ'D	PART NO.	DESCRIP
LIST OF MATERIALS			
DRAWN DATE		- IFR INC - MCHITA KALP	
TJT 6-27-77		TITLE	
CHECKED DATE		TCXO	
2/5 7-77		OUTPUT DISTRIBUTION	
APPROVED DATE		SCHEMATIC	
MO 7-77		SIZE	PART NUMBER
MATERIAL		B	2-23-0623
SCALE		WT. GR	HEET OF

DATE	REV	CHANGE	APP'D
1/27/78	A	INC ECN # 2570 A.A.	WW
1-15-78	A-1	INC ECN 2709	WW

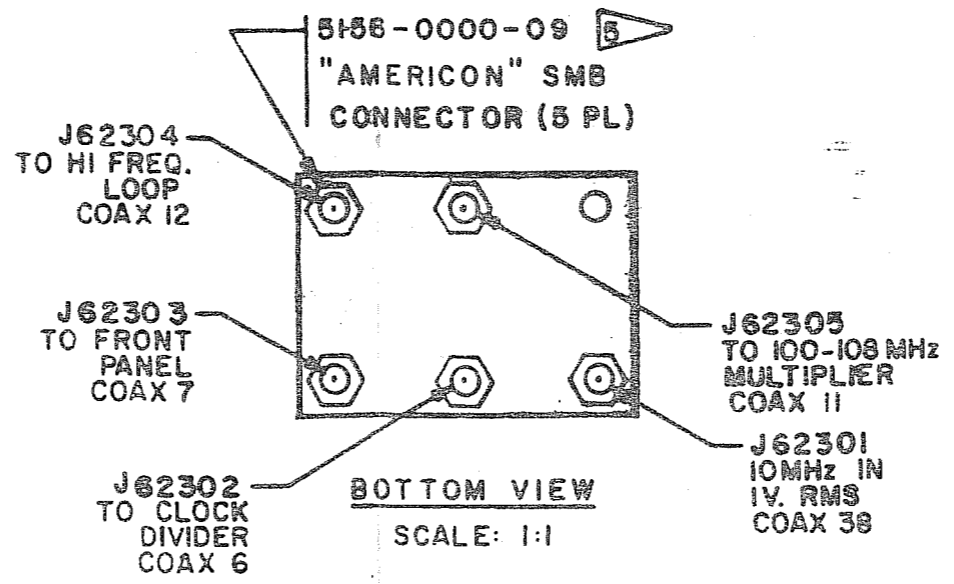
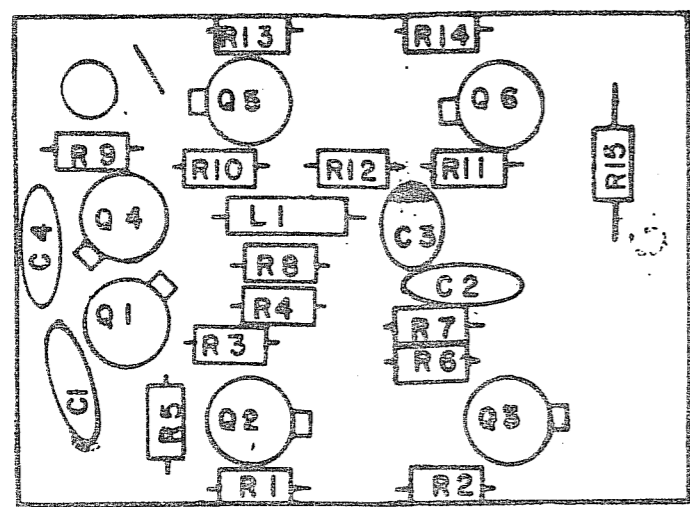

BOTTOM VIEW  
SCALE: 1:1

NOTES:

1. ALL RESISTORS ARE 1/8 W., 10% TOLERANCE EXCEPT AS NOTED.
  2. ALL CAPACITOR VALUES ARE IN  $\mu$ F EXCEPT AS NOTED.
  3. COMPONENT LEADS MAY EXTEND .04 TO .06 BEYOND BOTTOM OF BOARD AFTER SOLDERING.
  4. MAXIMUM HEIGHT OF COMPONENTS TO BE .45 FROM COMPONENT SIDE OF BOARD.
- 5  $\nabla$  TEFLON INSULATOR MUST BE CUT FLUSH WITH BASE OF CONNECTOR.

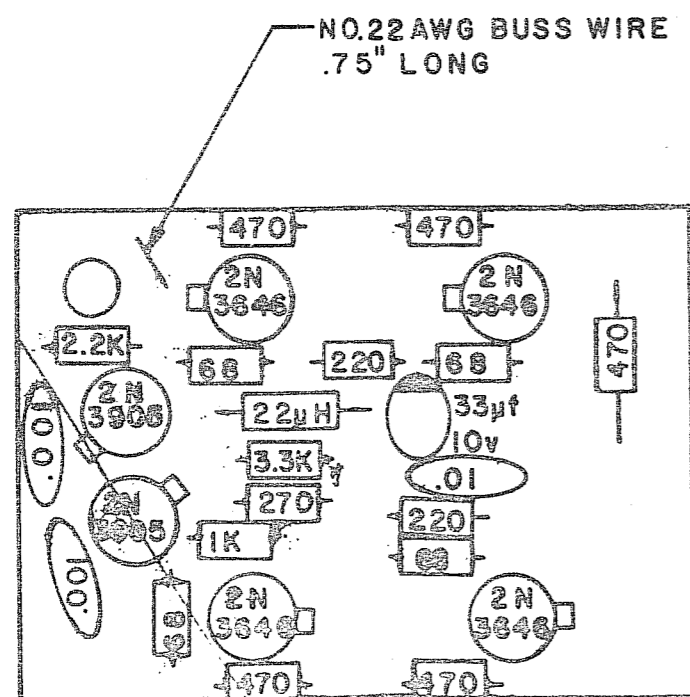

23-0620	1	FM/AM1000S					
					23-0619	TCXO P.C. BD ASS'Y	
NEXT ASS'Y	QTY	MODEL	ITEM	REQ'D	PART NO.	DESCRIPTION	
APPLICATION				LIST OF MATERIALS			
TOLERANCES		DRAWN DATE		INSTRUMENT FLIGHT RESEARCH CORPORATION			
UNLESS OTHERWISE SPECIFIED		RKK 3/13/77		WICHITA, KANSAS			
ALL DIMENSIONS APPLY AFTER FINISH		CHECKED DATE		TITLE			
DECIMALS: 2 .000		WW 4-8-77		TCXO OUTPUT DIST.			
ANGLES: 2 1/2°		APPROVED DATE		AMP ASS'Y			
FRACTIONS: 2 1/64		MA 49-77					
SURFACE ROUGHNESS 125							
REMOVE ALL BURRS							
MATERIAL		SIZE		PART NUMBER		REV	
		B		2-23-0619		A-1	
FINISH		SCALE		WEIGHT		SHEET 1 OF 1	
		2:1 & NOTED					

# CHANGE NOTICE #1

FM/AM-1000S, units S/N 801 through S/N 1615. The Duty Cycle Regulator Assembly has been changed to incorporate the modifications shown (also reference Assembly Dwg. No. 4-23-0384 [Fig. 6-15] and Schematic 3-23-0051 [Fig. 6-11] in July, 1978, printing of FM/AM-1000S manual).

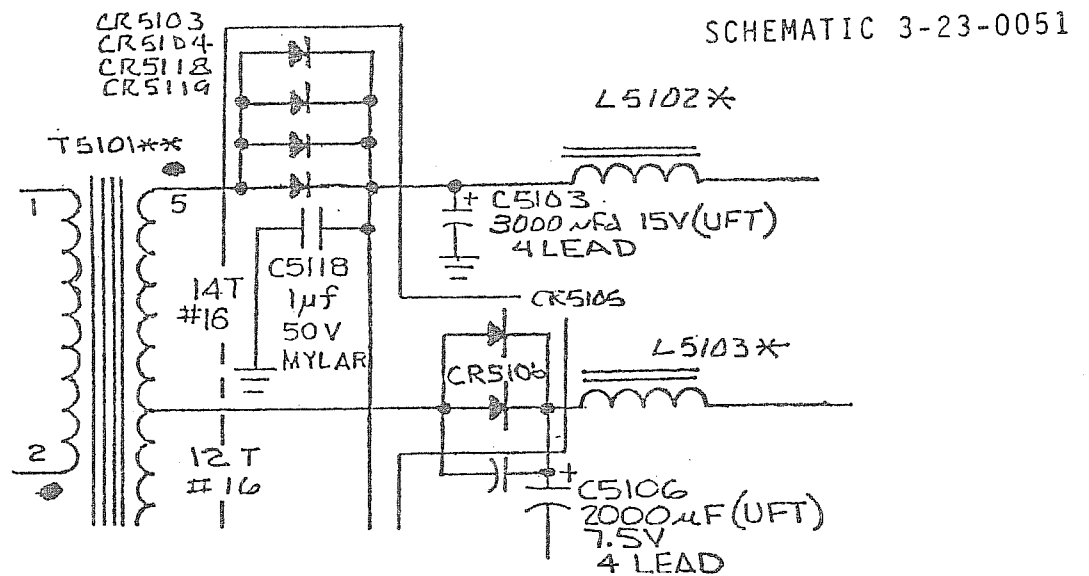
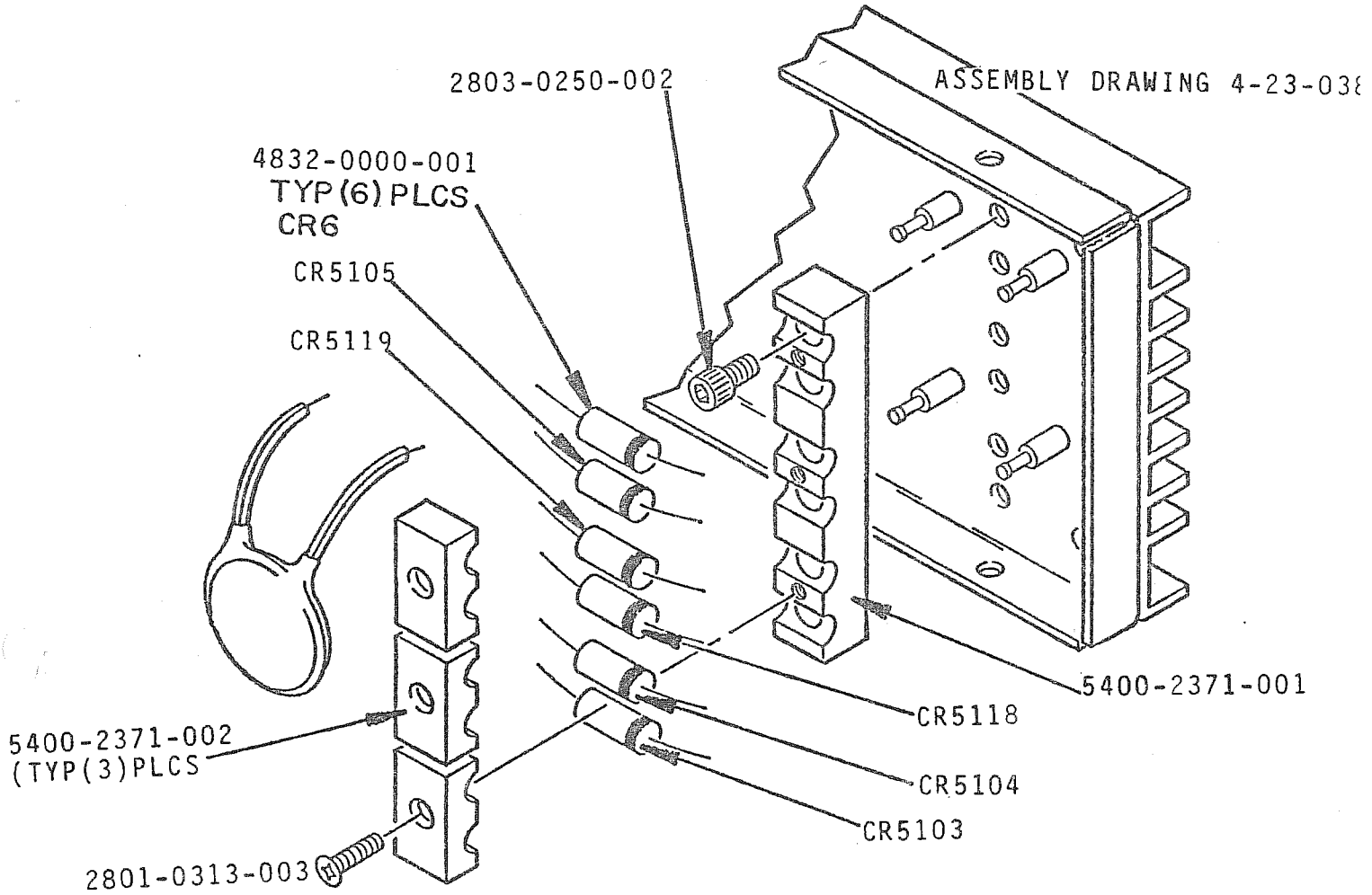

DUTY CYCLE REGULATOR - S/N 801 through S/N 1285



CHANGE NOTICE #1 - Continued

ASSEMBLY DRAWING 4-23-0384

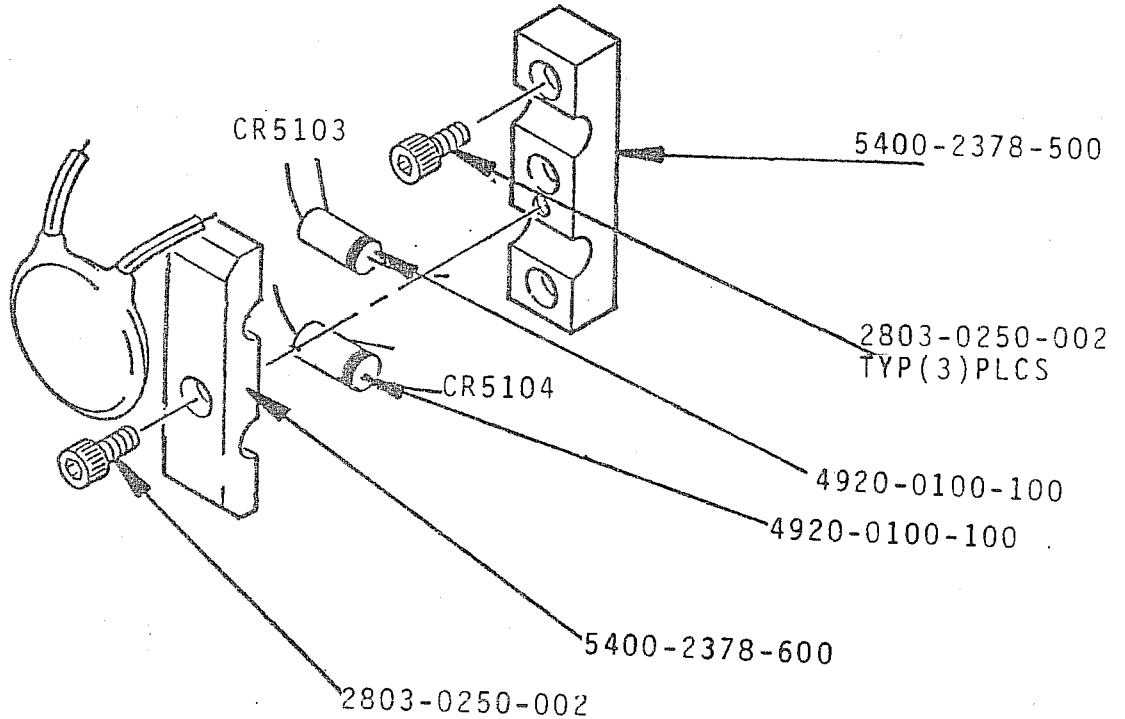

SCHEMATIC 3-23-0051

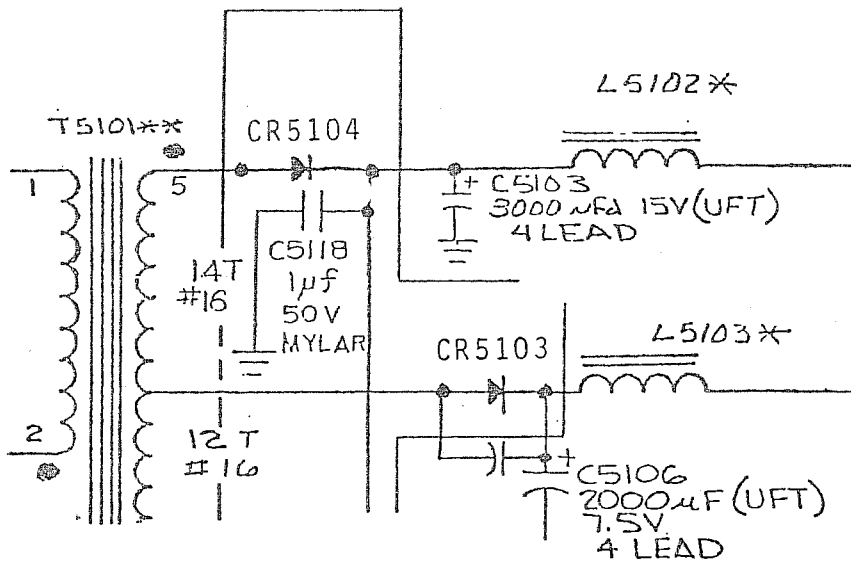

DUTY CYCLE REGULATOR - S/N 1286 and ON

CHANGE NOTICE #2

FM/AM-1000S, units S/N 801 through S/N 1615. The Rear Panel Assembly has been changed to incorporate the modifications shown (also reference Wiring Assembly, Dwg. No. 3-23-0380 [Fig. 6-5] and Schematic 3-23-0403 [Fig. 6-4] in July, 1978, printing of FM/AM-1000S manual).

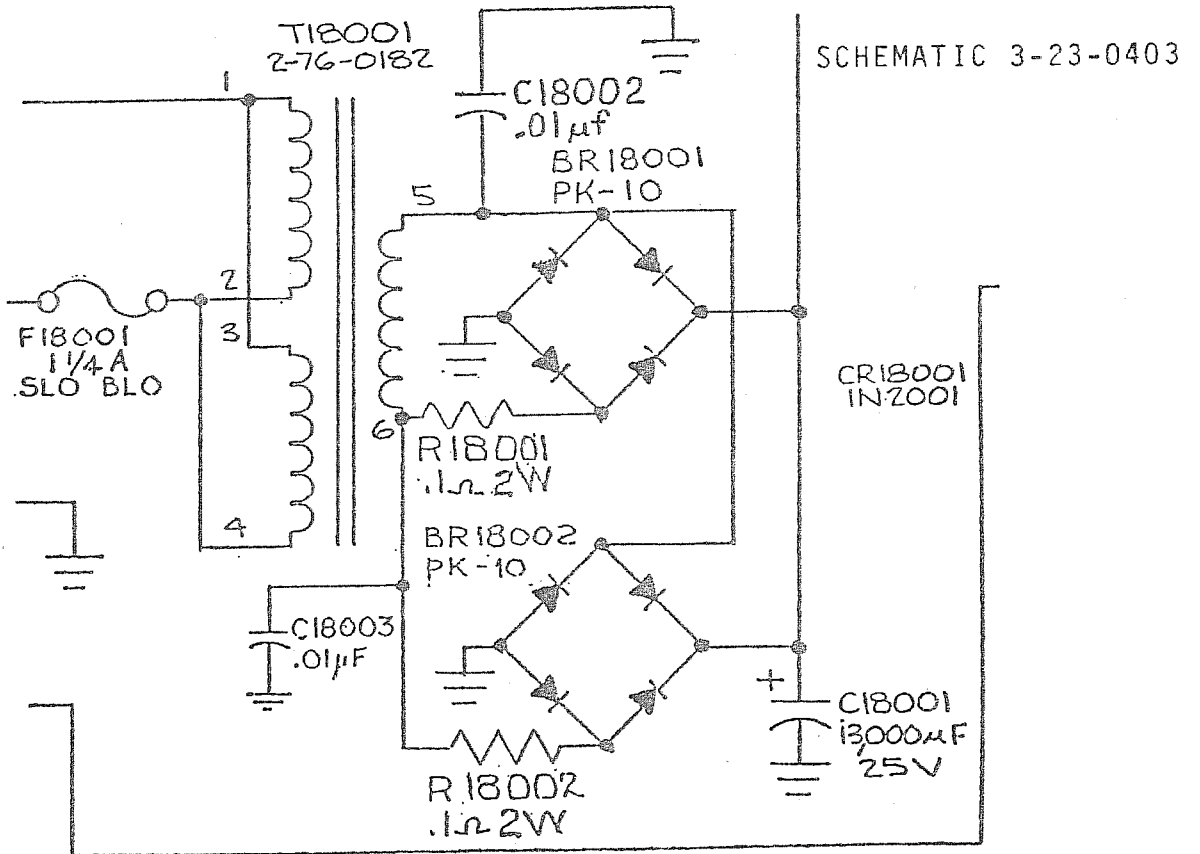
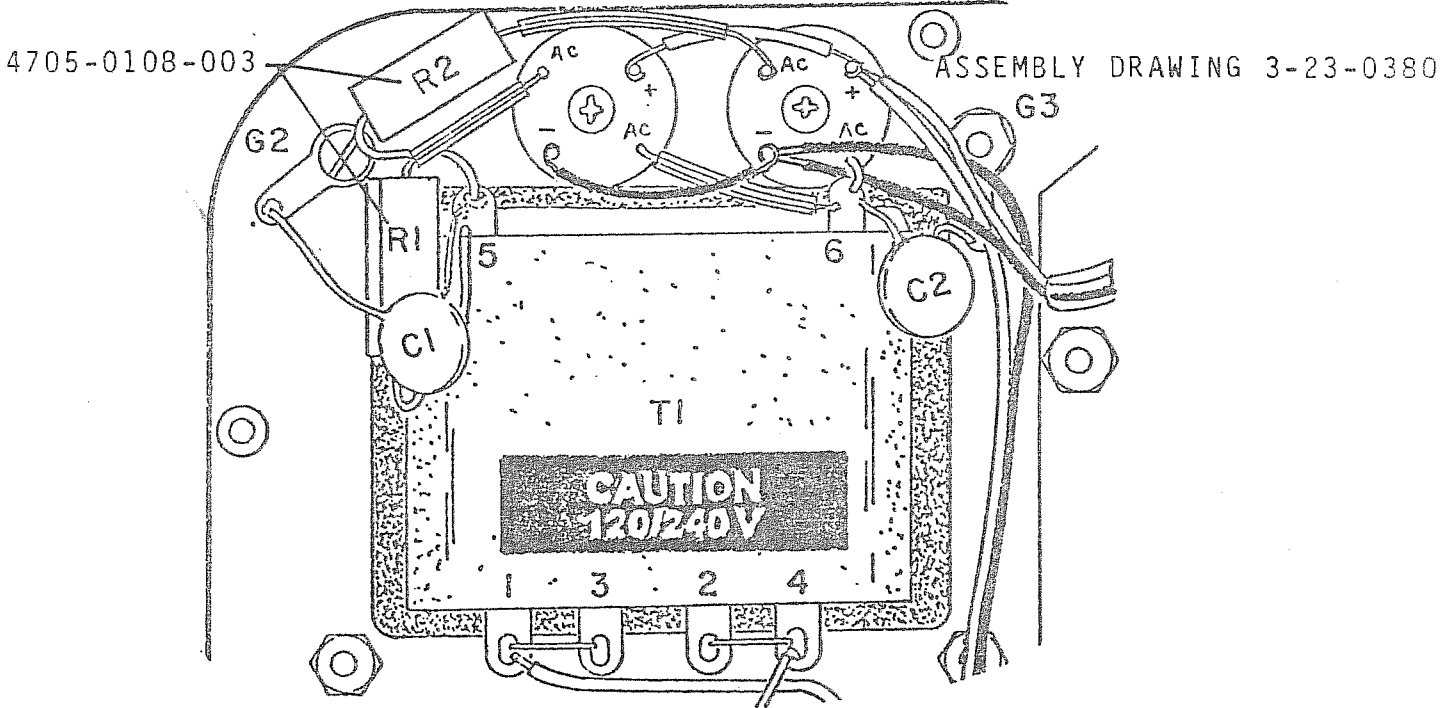

REAR PANEL - S/N 801 through S/N 1390

CHANGE NOTICE #2 - Continued

ASSEMBLY DRAWING 3-23-0380

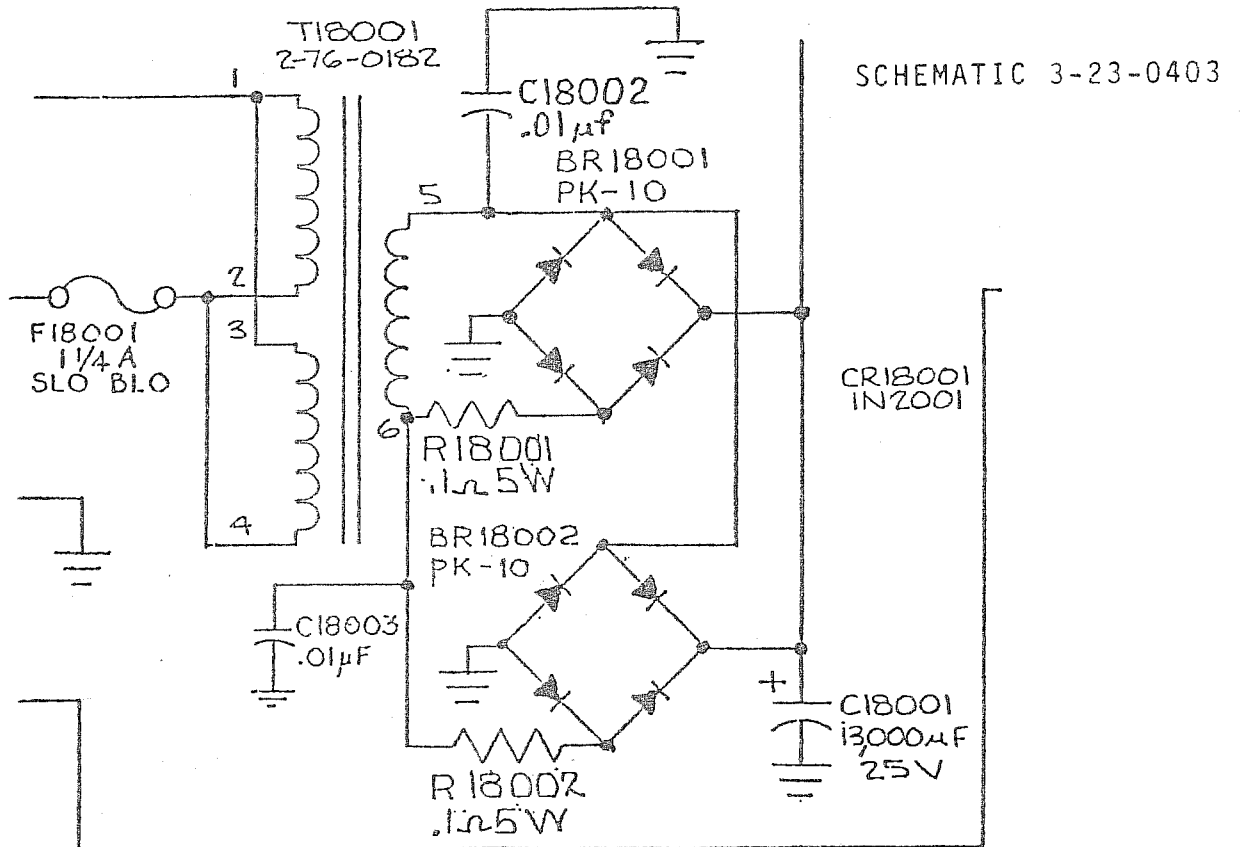
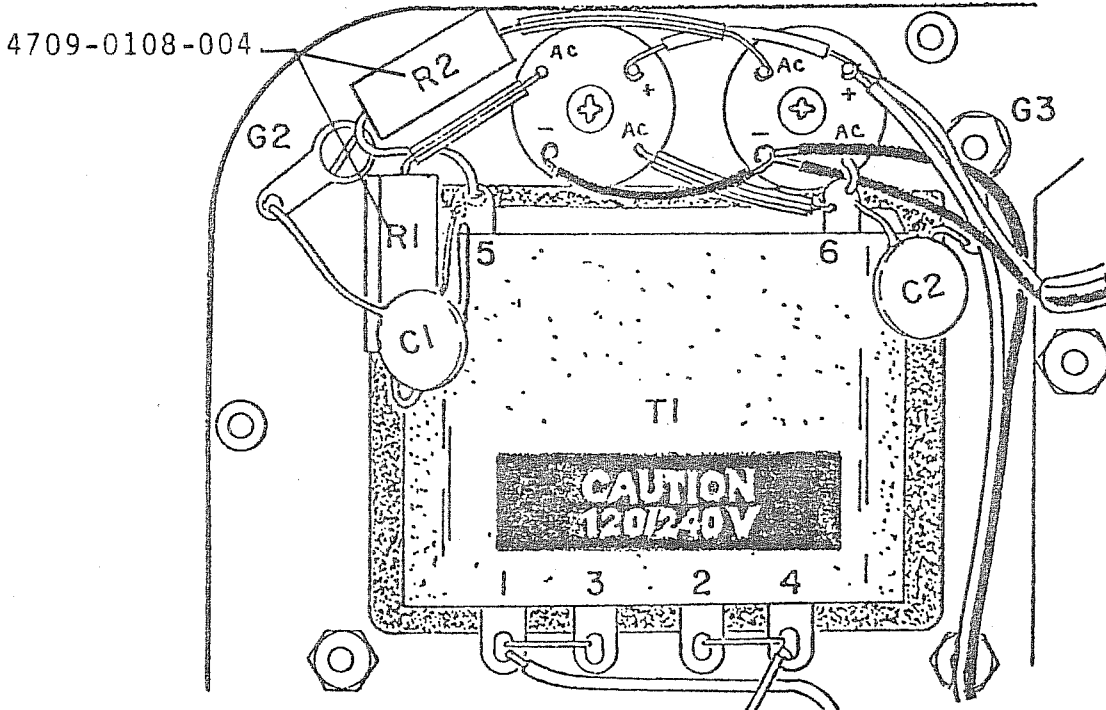

REAR PANEL - S/N 1391 and ON

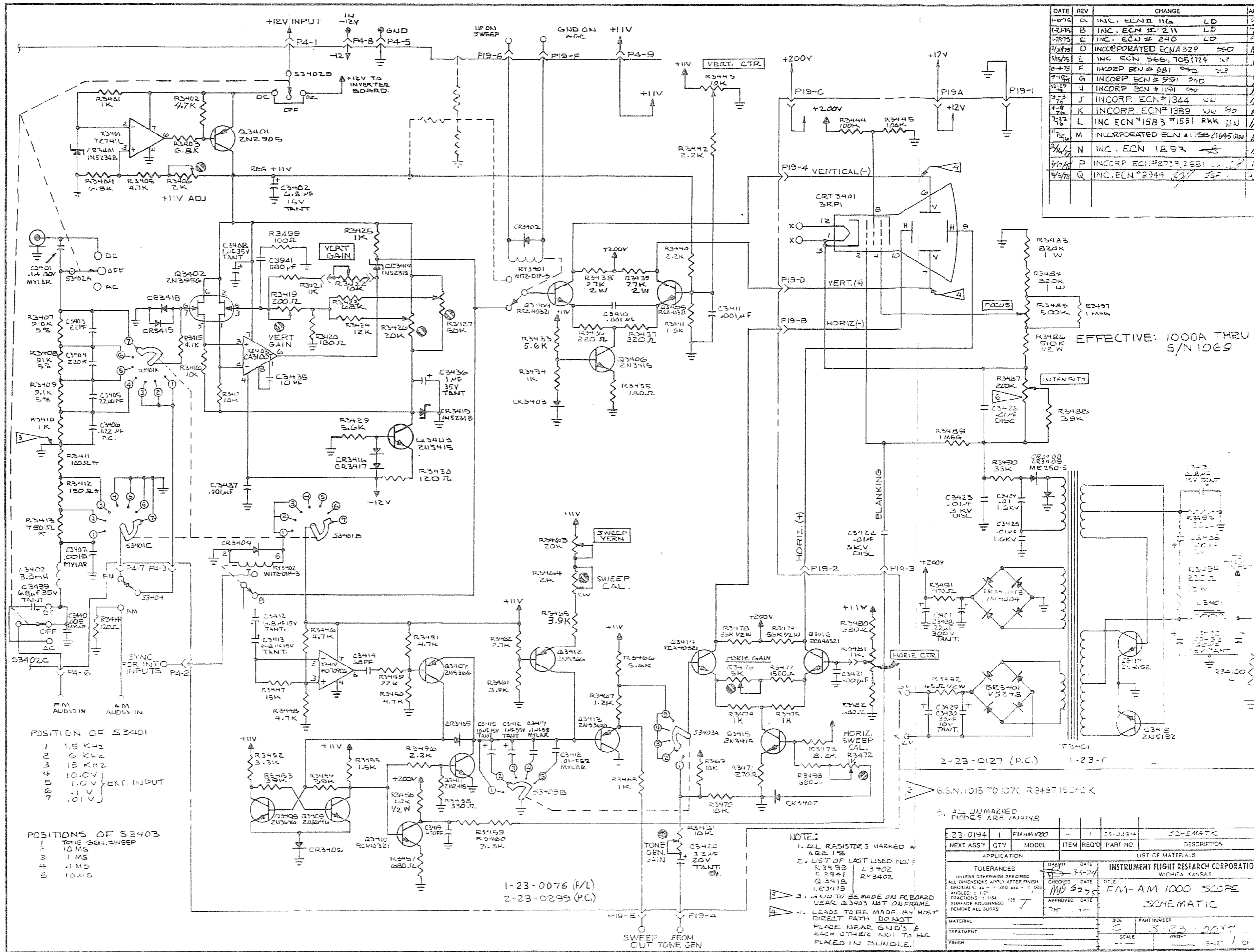

DATE	REV	CHANGE	AP
1-6-76	A	INC. ECN# 116	LD
1-21-76	B	INC. ECN # 211	LD
1-25-76	C	INC. ECN # 240	LD
7/27/77	D	INCORPORATED ECN# 329	SSD
5/15/75	E	INC ECN 566, 705, 724	LD
6-4-75	F	INCORP ECN # 881	LD
7/29/75	G	INCORP ECN # 991	LD
11-29/75	H	INCORP ECN # 1191	LD
3-3/76	J	INCORP ECN # 1344	LD
7-9/76	K	INCORP ECN # 1389	LD
7-22/76	L	INC ECN # 1583 # 1551 RKK	LD
11-25/76	M	INCORPORATED ECN # 1758 # 1645	LD
3/14/77	N	INC. ECN 1893	LD
4/17/77	P	INCORP ECN # 2732, 2851	LD
8/5/78	Q	INC. ECN # 2944	LD

- POSITION OF S3401
- 1 1.5 KHZ
  - 2 6 KHZ
  - 3 15 KHZ
  - 4 10.0V
  - 5 1.0V
  - 6 1.0V
  - 7 .01V
- EXT. INPUT
- POSITIONS OF S3403
- A 10MS
  - B 1MS
  - C 1MS
  - D 10MS

1-23-0076 (P/L)  
2-23-0299 (P.C.)

NOTE:

1. ALL RESISTORS MARKED \* ARE 1%.
2. LIST OF LAST USED NOS: R3459 23402, R3441 RY3402, R3419 RY3402, R3419 RY3402.
3. GND TO BE MADE ON P.C. BOARD. LEADS TO BE MADE BY MOST DIRECT PATH. DO NOT PLACE NEAR GND'S & EACH OTHER. NOT TO BE PLACED IN BUNDLE.

DATE	REV	CHANGE	AP
23-0194	1	FM AM 1020	SS-BATC

APPLICATION	DATE	TITLE
INSTRUMENT FLIGHT RESEARCH CORPORATION	3-5-74	FM-AM 1000 SCORE SCHEMATIC

TOLERANCES	DATE	SCALE
UNLESS OTHERWISE SPECIFIED	3-5-74	3-23-0076

DATE	REV	CHANGE	APP'D
11/17/77	A	INCORP. ECN 2195 AA	MD
11/17/77	B	INCORP. ECN 2363 LA	MD
11/17/77	C	INC. ECN 2822	MD
11/17/77	D	INC. ECN 2828	MD

- NOTE
- KEEP AWAY FROM GND'S & EACH OTHER. KEEP DIRECT. DO NOT BUNDLE.
  - ALL RESISTORS ARE 1/8W, 10% TOLERANCE EXCEPT AS NOTED.
  - RESISTORS IDENTIFIED WITH ASTERISK (\*) ARE 1/4 W, 1% TOLERANCE.

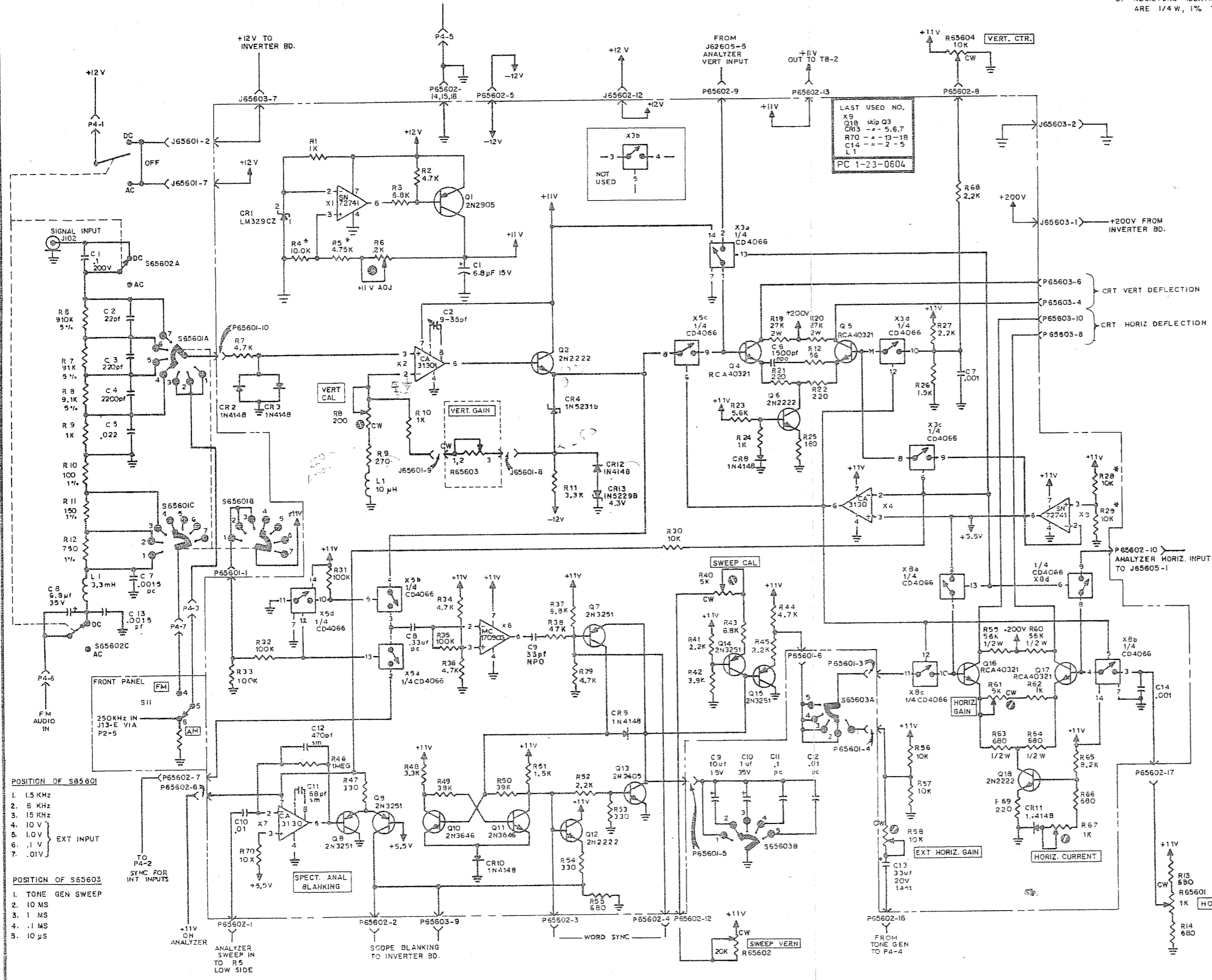

EFFECTIVE: FM/AM1000A S/N1070 & ON

ITEM	QTY	PART NO	DESCRIPTION
R65601	1K		HORIZ. CTR.
R65602	20K		SWEEP VERN
R65603	1K		HORIZ. CTR.
R65604	10K		VERT. CTR.

FM-AM 1000A SCOPE SCHEMATIC (WITH WORD SYNC & SPECTRUM ANALYZER PROVISIONS)

DATE: 11/17/77

APP'D: MD

REV: D

4-23-082

PC BD ASSY #1 7010-2374-600  
DUAL TONE GEN. ASSY 7005-2375-300

PC BD ASSY #2 7010-2374-900  
DUAL TONE GEN. ASSY 7005-2375-300

REV	A	INC	ECA	35	RF
-----	---	-----	-----	----	----

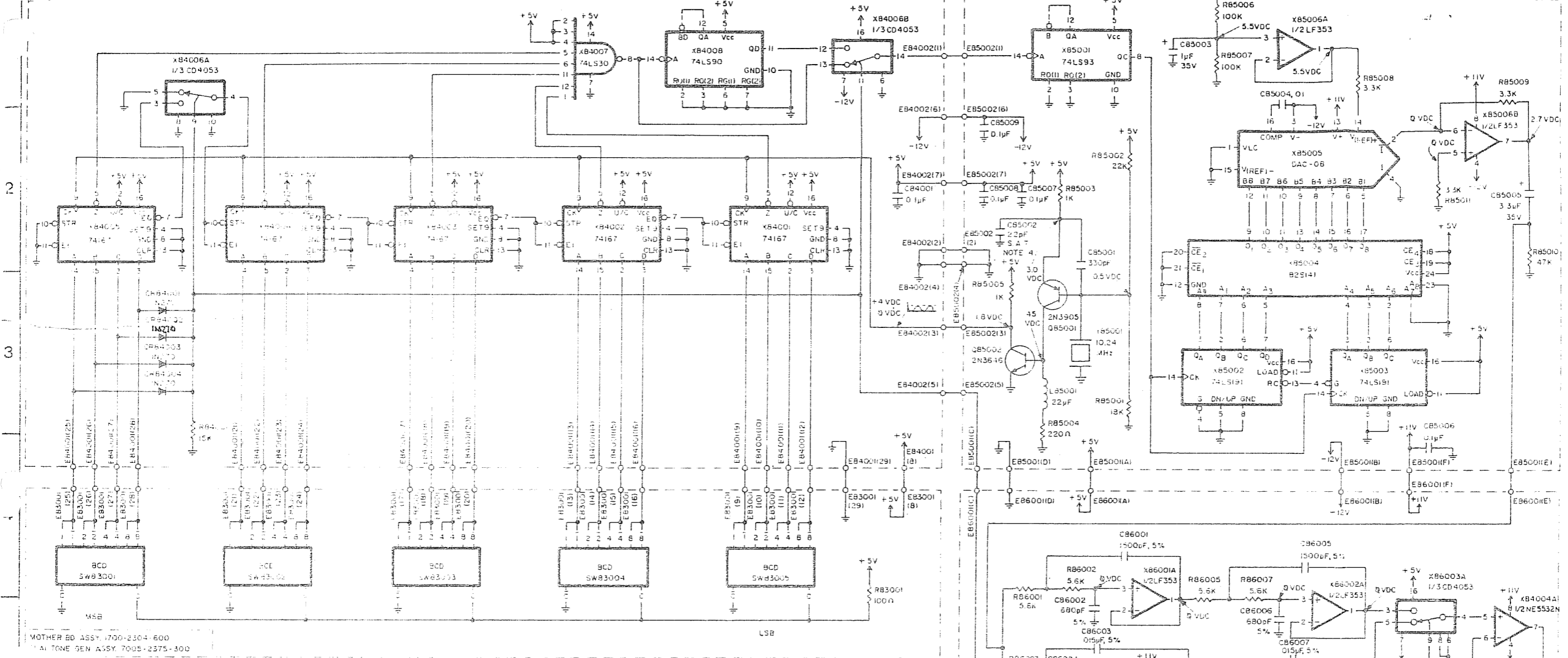

MOTHER BD ASSY 7000-2304-600  
DUAL TONE GEN ASSY 7005-2375-300

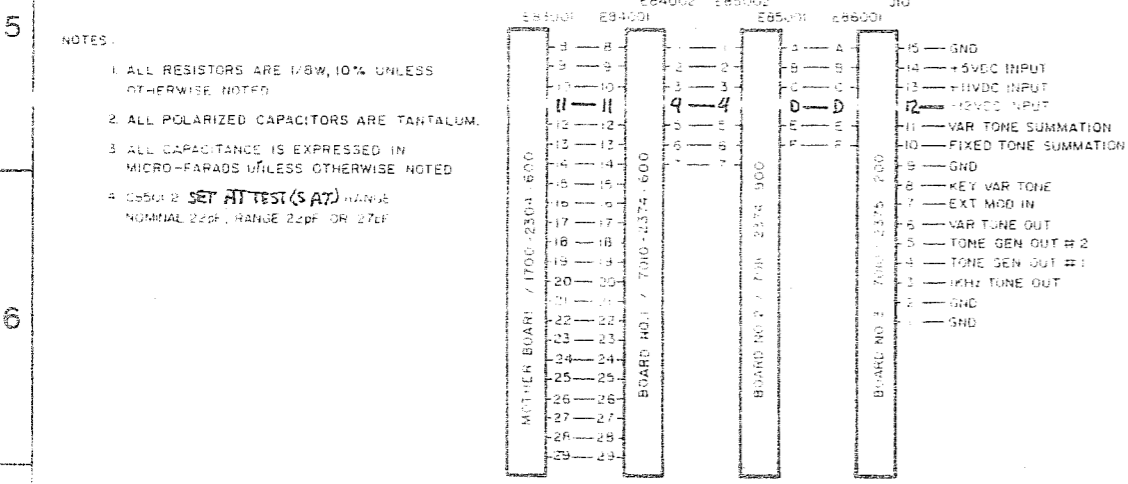

DUAL TONE GENERATOR INTERCONNECT

- NOTES:
1. ALL RESISTORS ARE 1/8W, 10% UNLESS OTHERWISE NOTED.
  2. ALL POLARIZED CAPACITORS ARE TANTALUM.
  3. ALL CAPACITANCE IS EXPRESSED IN MICRO-FARADS UNLESS OTHERWISE NOTED.
  4. SET AT TEST (SAT) RANGE NOMINAL 22pF, RANGE 24pF OR 27pF.

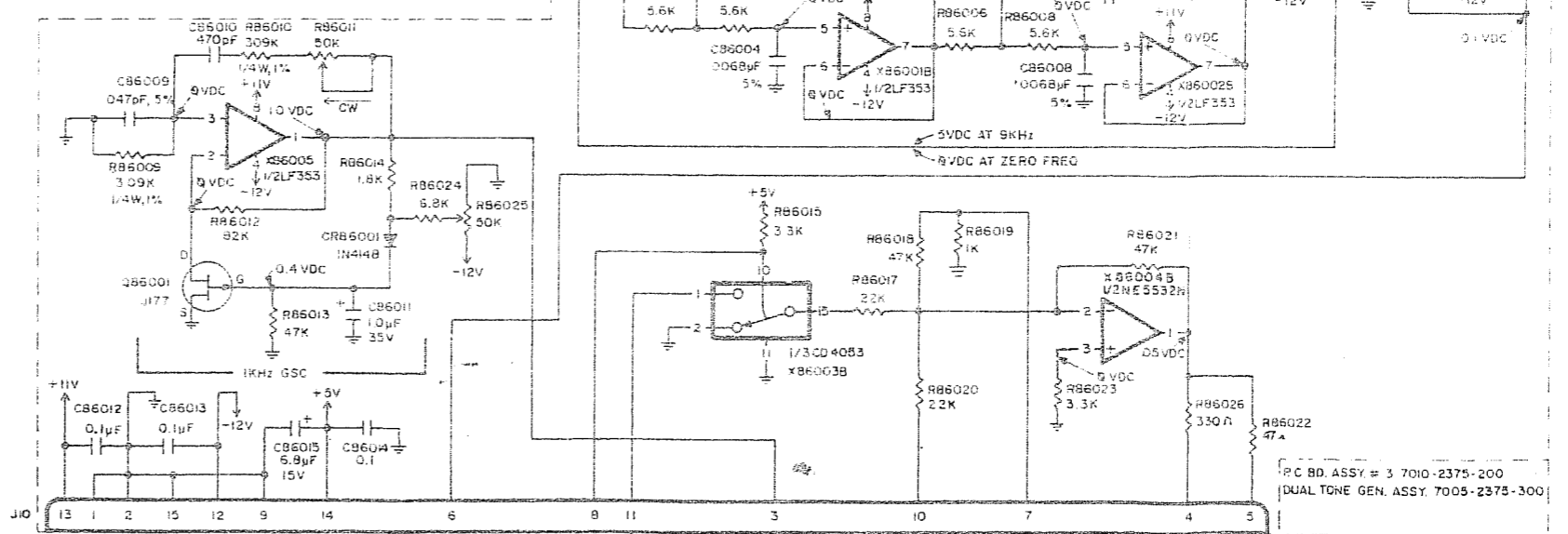

TO FRONT PANEL SWITCH

PC BD ASSY #3 7010-2375-200  
DUAL TONE GEN. ASSY 7005-2375-300

REV	A	INC	ECA	35	RF
-----	---	-----	-----	----	----

52

DATE	REV	CHANGE	APP'D

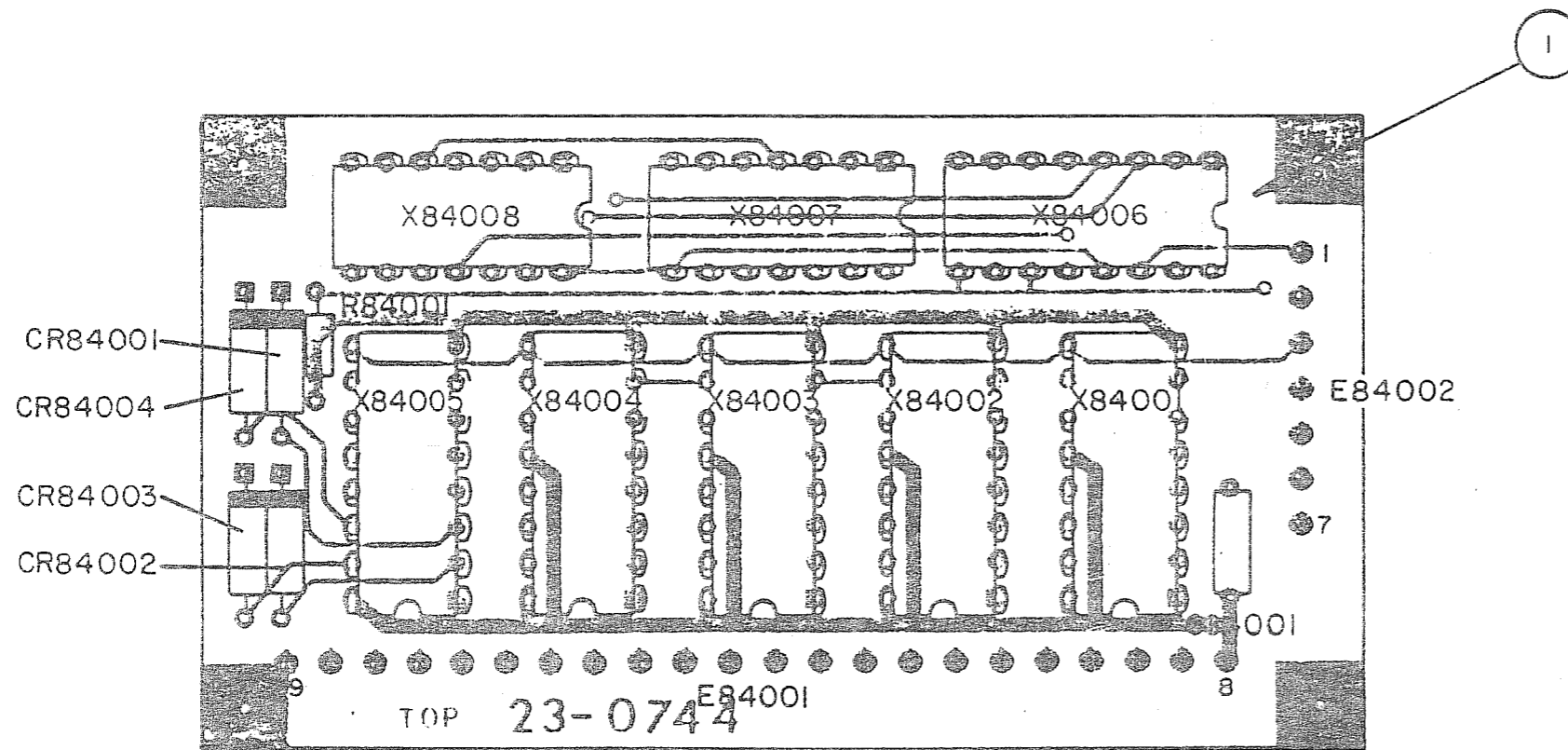

NOTES:

1. REFERENCE CIRCUIT SCHEMATIC 0000-2374-300.

ITEM	REQ'D	PART NO.	DESCRIPTION
LIST OF MATERIALS			
<b>TOLERANCES</b> UNLESS OTHERWISE SPECIFIED ALL DIMENSIONS APPLY AFTER FINISH DECIMALS: .XX = ± .010 .XXX = ± .005 ANGLES: ± 1/2° FRACTIONS: ± 1/64 SURFACE ROUGHNESS 125 REMOVE ALL BURRS		DRAWN DATE ER 4-9-80 CHECKED DATE J. Adams 11-6-80 APPROVED DATE BOGTH 11/6/80	- IPR INC - WICHITA, KANSAS TITLE DUAL TONE GEN. BD. #1 ASSY. FM-AM 1000 S
23-753	1	1000S	
NEXT ASSY QTY	MODEL	APPLICATION	
MATERIAL	SCALE	PART NUMBER	REV
FINISH	2 x 1	7010-2374-600	
	WEIGHT	SHEET	OF
	11	1	1

DATE	REV	CHANGE

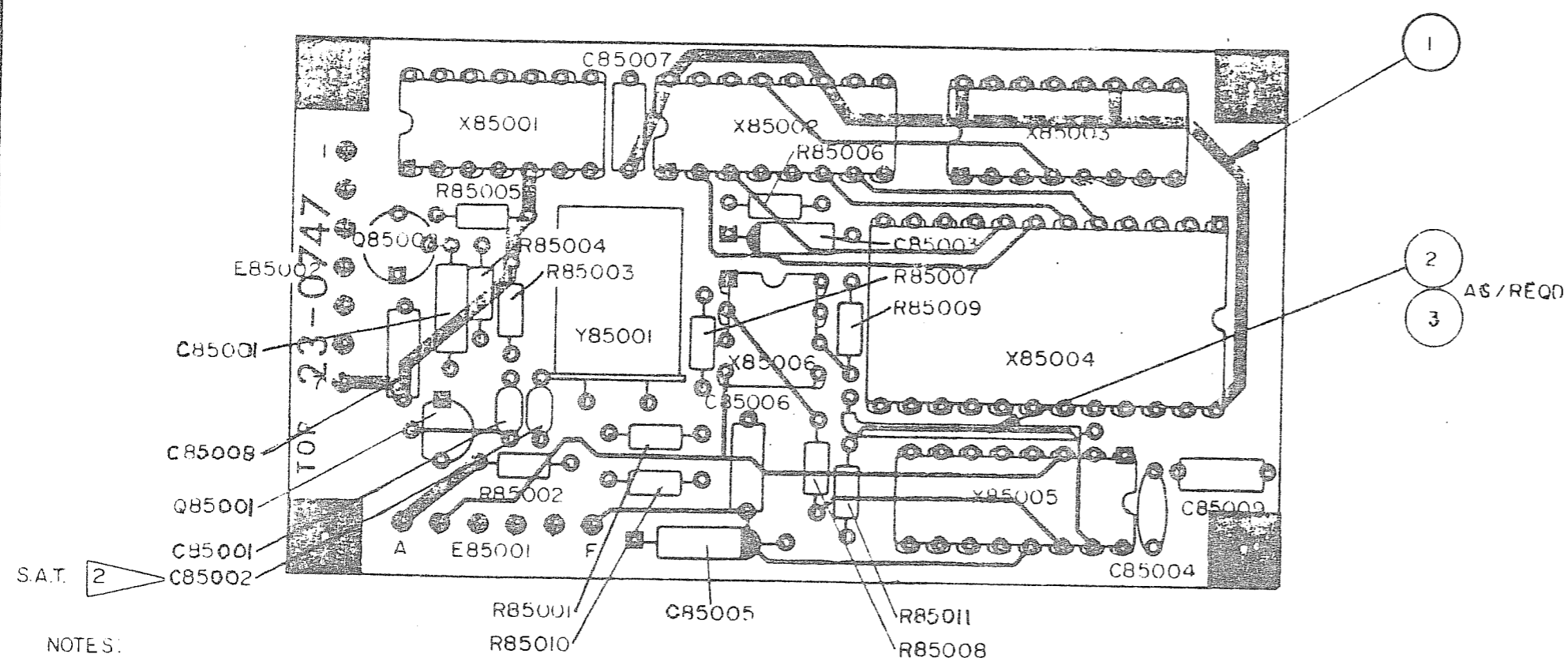

NOTES:

1. REFERENCE CIRCUIT SCHEMATIC 0000-2374-300.
2. C85002 SET AT TEST (S. A. T.) RANGE: NOMINAL 22pF; RANGE 22pF OR 27pF.

ITEM	REQ'D	PART NO.	DESCRIPTION
LIST OF MATERIALS			
TOLERANCES UNLESS OTHERWISE SPECIFIED ALL DIMENSIONS APPLY AFTER FINISH DECIMALS: .xx = ± .010 .xxx = ± .005 ANGLES: ± 1/2° FRACTIONS: ± 1/64 SURFACE ROUGHNESS 125 REMOVE ALL BURRS		DRAWN DATE ER 4/9/80 CHECKED DATE J Adams 11-6-80 APPROVED DATE BOROTH 11/16/80	- IFR INC - WICHITA, KANSAS TITLE DUAL TONE GEN. BD. #2 ASSY. FM-AM 1000 S
23-753	1	1000S	MATERIAL
23-753	1	1000S	FINISH
SIZE	PART NUMBER		WEIGHT
B	7010-2374-900		54
SCALE	SHEET 1 OF		
2 x 1			



DATE	REV	CHANGE	APPD
2-12-81	A	INC ECN 3591 RF	H

TOP VIEW

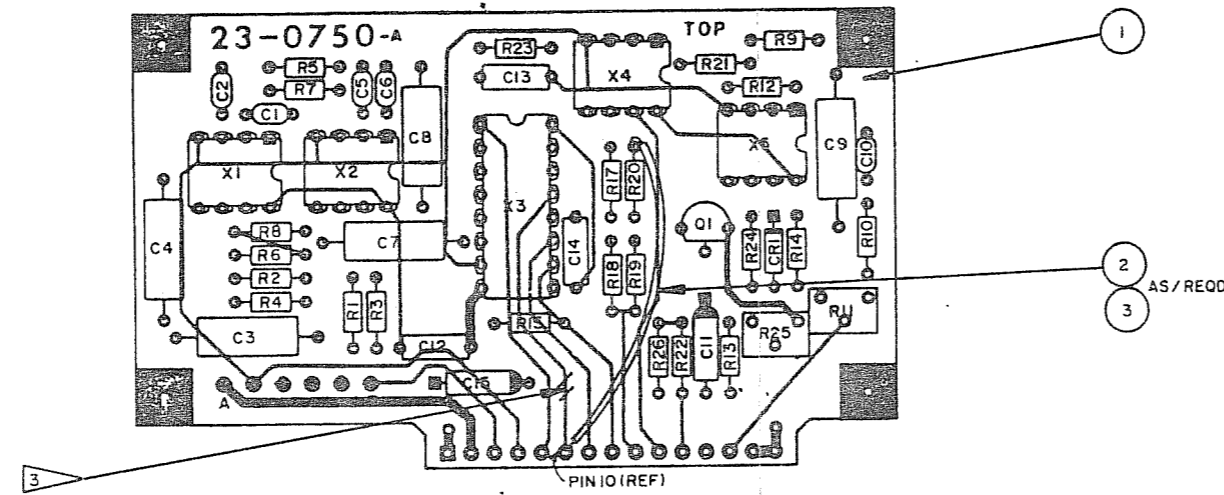

BOTTOM VIEW

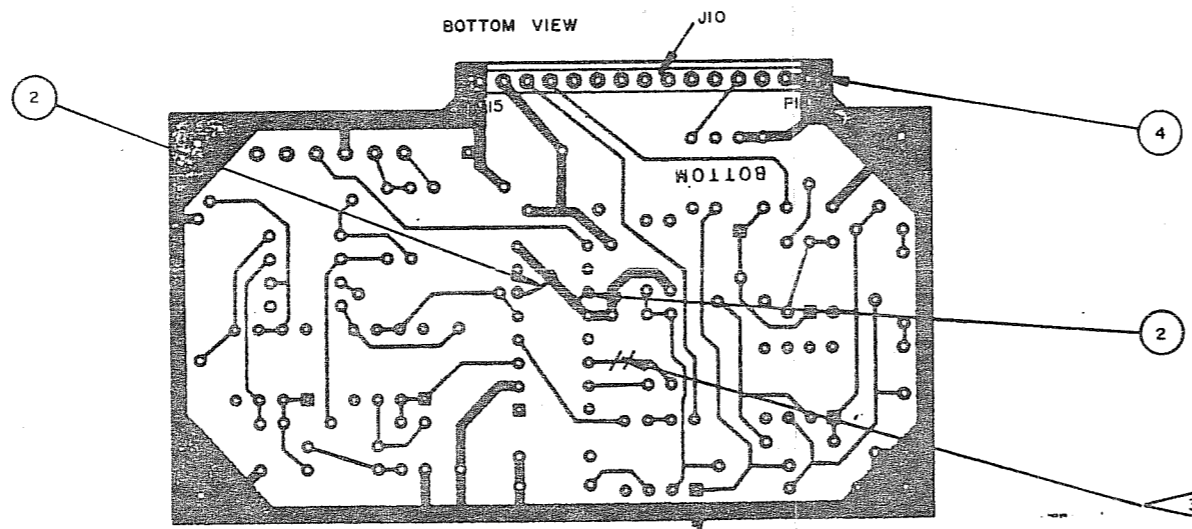

- NOTES:
1. FOR CABLE INTERCONNECT SEE 0000-2364-001.
  2. REFERENCE CIRCUIT SCHEMATIC 0000-2374-300.
  3. CUT AWAY PATHWORK AS INDICATED, TWO PLACES.

ITEM	REQ'D	PART NO.	DESCRIPTION
LIST OF MATERIALS			
TOLERANCES		DATE	- IPR INC -
UNLESS OTHERWISE SPECIFIED		ER 4/11/80	WICHITA, KANSAS
ALL DIMENSIONS APPLY AFTER FINISH		CHECKED	DATE
DECIMALS .05 = ± .010 .002 = ± .002		J. Adams 11-4-80	
ANGLES ± 1/2°		APPROVED DATE	
FRACTURES ± 1/64		BOROM 11/6/80	
SURFACE ROUGHNESS			
REMOVE ALL BURRS			
MATERIAL	SCALE	PART NUMBER	REV
FRS	2 x 1	7010-2373-200	A
SHEET 1 OF 1			

DATE	REV	CHANGE

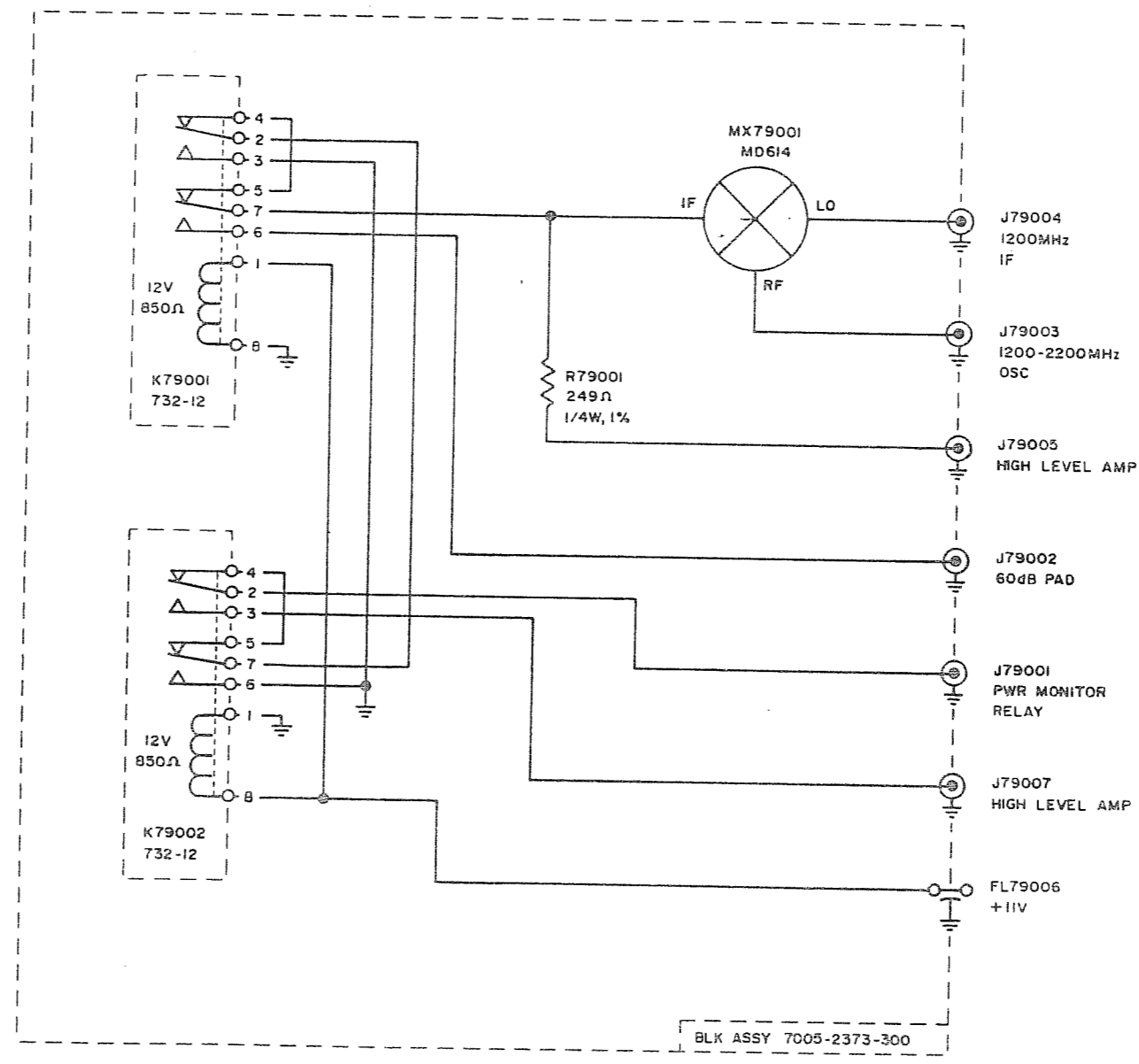

- NOTES:
- LAST REF. DES. USED:
    - FL79006
    - J79007
    - K79002
    - MX79001
    - R79001
  - REF. DES. NOT USED:
    - FL79001
    - FL79002
    - FL79003
    - FL79004
    - FL79005
    - J79006

ITEM	REQ'D	PART NO.	DESCRIPTION
LIST OF MATERIALS			
TOLERANCES			DRAWN DATE
UNLESS OTHERWISE SPECIFIED			ER 3/31/80
ALL DIMENSIONS APPLY AFTER FINISH			CHECKED DATE
DECIMALS: .01 - .010 .020 - .050			J. Adams 4-10-80
ANGLES: 1/16"			APPROVED DATE
FRACTIONS: 1/16"			3-20-80 4/6/80
SURFACE FINISHES			TITLE
REMOVE ALL BURRS			FIRST MIXER & SWITCH
			CIRCUIT SCHEMATIC
			FM - 1000 S
MATERIAL	SIZE	PART NUMBER	SCALE
			C 0000-2377-100
FINISH	SCALE		NONE

DATE	REV	CHANGE	APPRD
3/18/80	A	INC ECN 3636 RF	

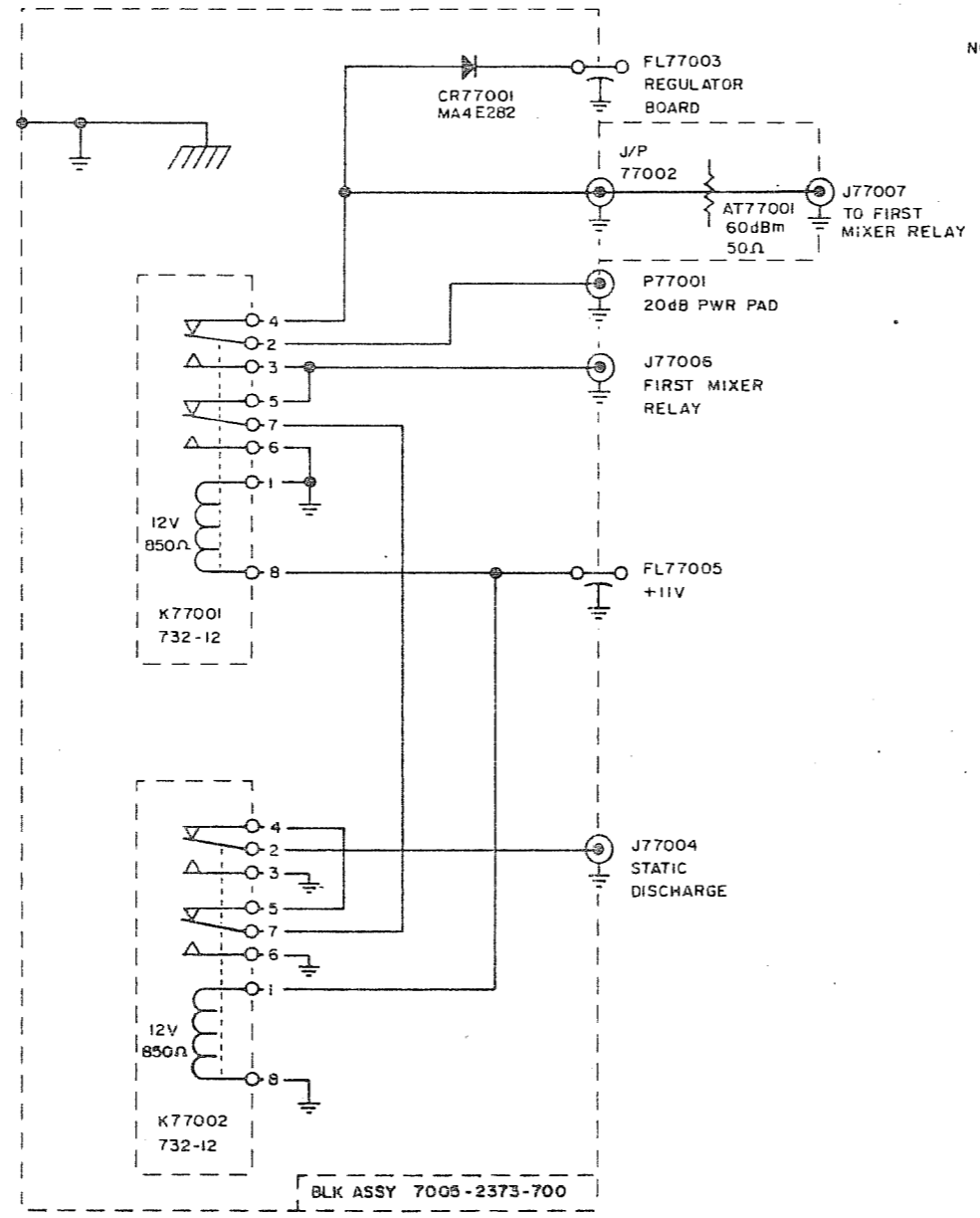

- NOTES:
- LAST REF DES. USED:
    - AT77001
    - CR77001
    - FL77005
    - J77006
    - K77002
    - P77001
  - REF DES. NOT USED:
    - FL77001
    - FL77002
    - FL77004
    - J77003
    - J77005

ITEM	REQ'D	PART NO.	DESCRIPTION
LIST OF MATERIALS			
- IFR 130C - WICHITA, KANSAS			
TOLERANCES UNLESS OTHERWISE SPECIFIED ALL DIMENSIONS APPLY AFTER FINISH DECIMALS .01 .010 .001 .0005 FRACTIONS 1/32 1/64 SURFACE ROUGHNESS REMOVE ALL BURRS		DRAWN DATE ER 3/28/80	CHECKED DATE J. Adams 4-6-80
MATERIAL //		APPROVED DATE ER 3/28/80	TITLE POWER MONITOR ASSY CIRCUIT SCHEMATIC FM-AM 1000.5
FINISH //		SCALE NONE	DATE C
		WEIGHT //	PART NUMBER 0000-2377-200
			REV A
			SHEET 1 OF 1

DATE	REV	CHANGE
31181	A	INC. ECM 3636 RF

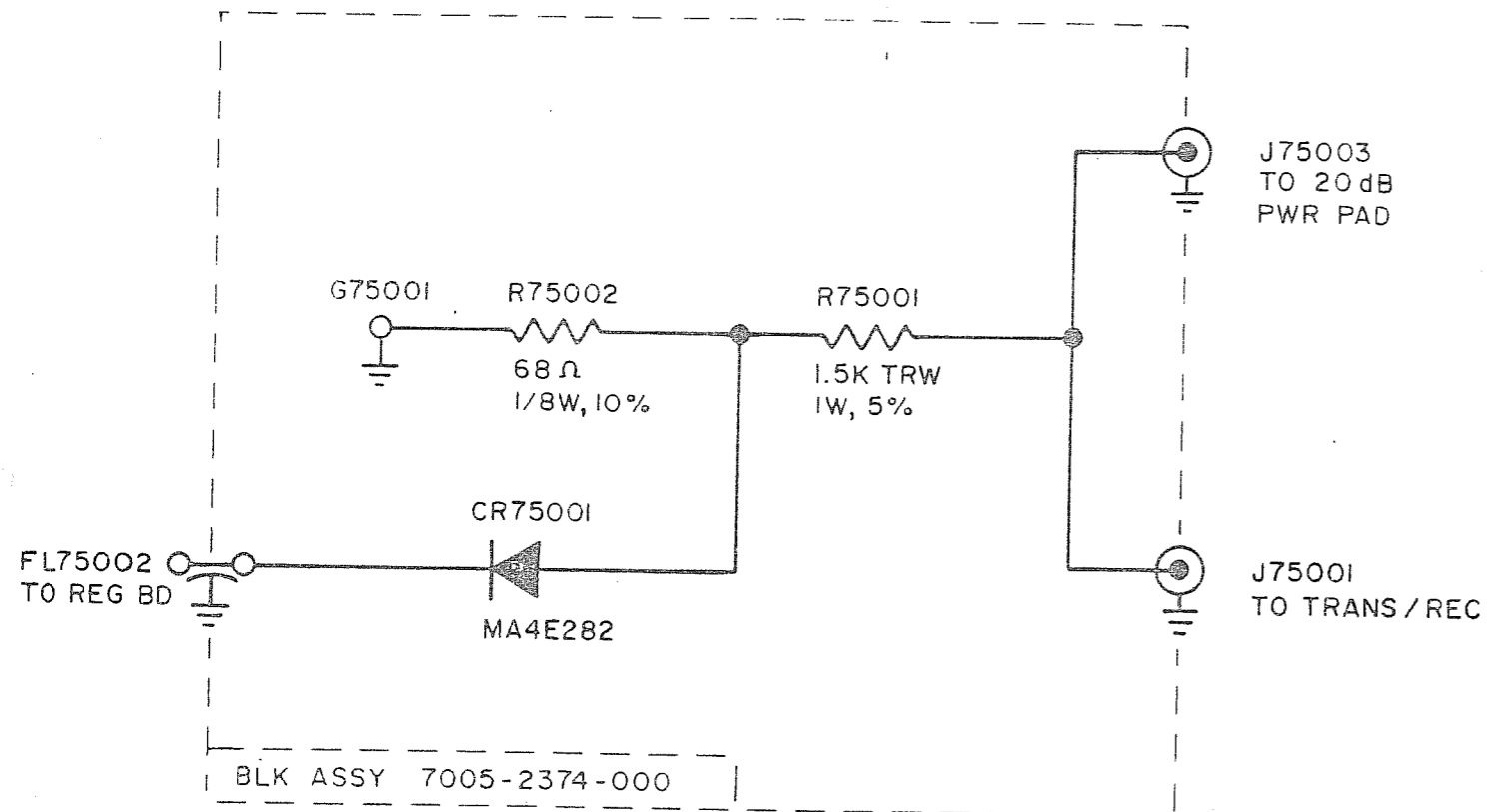

NOTES :

1. LAST REF DES USED :

- CR75001
- FL75002
- G75001
- J75003
- R75002

2. REF DES NOT USED :

- FL75001
- J75002

ITEM	REQ'D	PART NO.	DESCRIPTION
LIST OF MATERIALS			
		- IFR INC - WICHITA, KANSAS	
		TITLE	
		XMTR SENSOR ASSY CIRCUIT SCHEMATIC FM-AM 1000 S	
		PART NUMBER	
		0000-2377-300	
		SCALE	
		NONE	
		WEIGHT	
		//	
		SHEET 1 OF	

23-740	1	1000S
NEXT ASSY QTY	MODEL	APPLICATION

TOLERANCES		DRAWN DATE
UNLESS OTHERWISE SPECIFIED		ER 4/3/80
ALL DIMENSIONS APPLY AFTER FINISH		CHECKED DATE
DECIMALS: .XX ± .010 .XXX ± .005		J. Adams 11-6-80
ANGLES: + 1/2°		APPROVED DATE
FRACTIONS: ± 1/64		WICHITA 11/6/80
SURFACE ROUGHNESS		
REMOVE ALL BURRS		

DATE	REV	CHANGE	APP'D

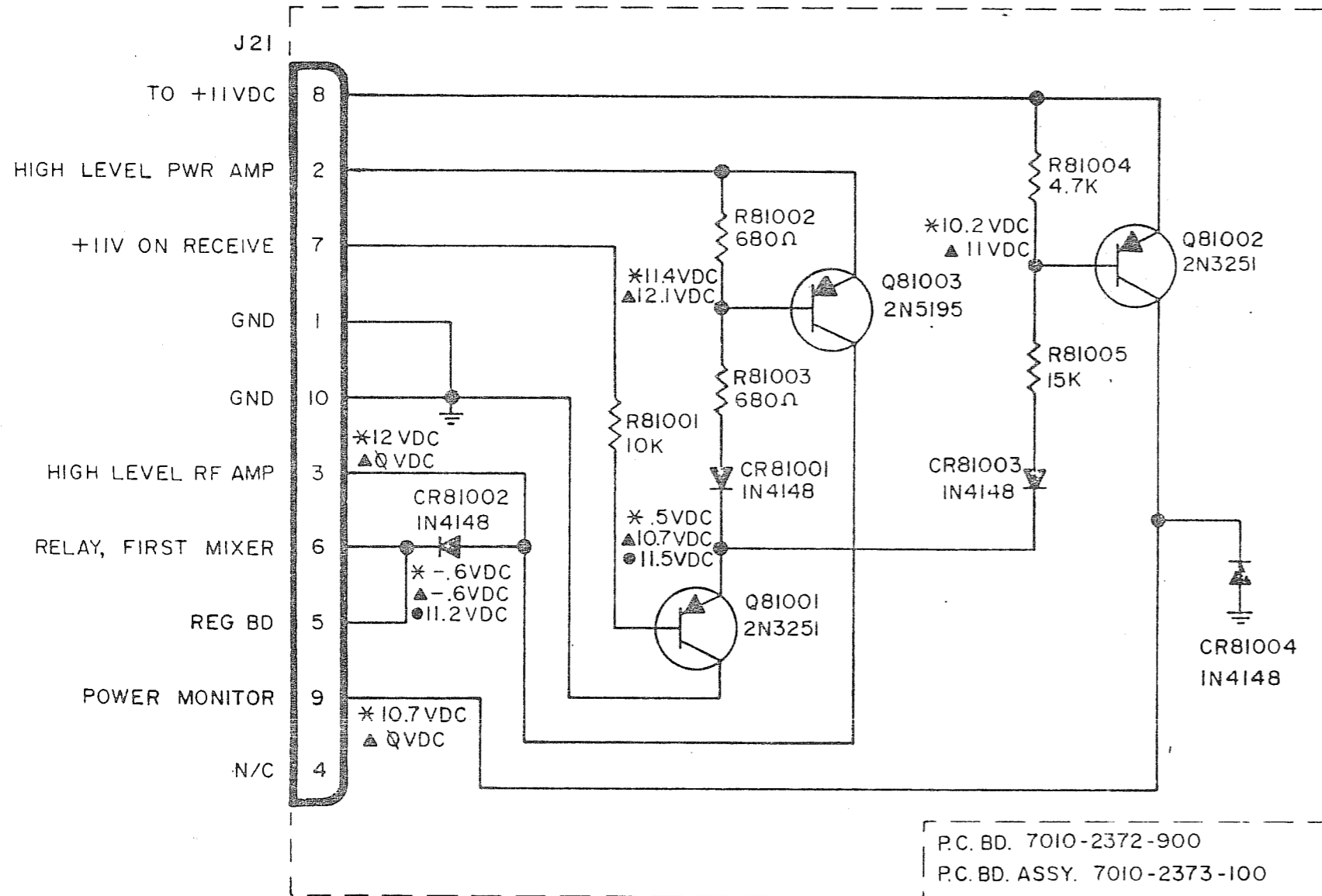

NOTES:

1. TEST VOLTAGE VALUE LEGEND:

- \* GEN VDC
- ▲ REC VDC
- HIGH LEVEL VDC

2. LAST REF. DES. USED:

- CR81004
- J21
- Q81003
- R81005

ITEM	REQ'D	PART NO.	DESCRIPTION
LIST OF MATERIALS			
TOLERANCES		DRAWN DATE	<b>- IFR INC -</b> WICHITA, KANSAS TITLE <b>RELAY DRIVER</b> <b>CIRCUIT SCHEMATIC</b> <b>FM-AM 1000 S</b>
UNLESS OTHERWISE SPECIFIED		ER 5/20/80	
ALL DIMENSIONS APPLY AFTER FINISH		CHECKED DATE	
DECIMALS: .xx = ± .010 .xxx = ± .005		J Adams 11-6-80	
ANGLES: ± 1/2°		APPROVED DATE	REV
FRACTIONS: ± 1/64		BOC 7/1/80	
SURFACE ROUGHNESS: 125			
REMOVE ALL BURRS			
MATERIAL	FINISH		SIZE
			B
		SCALE	PART NUMBER
		NONE	0000-2372-800
		WEIGHT	REV
		---	
		SHEET	OF

23-731 1000S  
 NEXT ASSY QTY MODEL  
 APPLICATION

DATE	REV	CHANGE

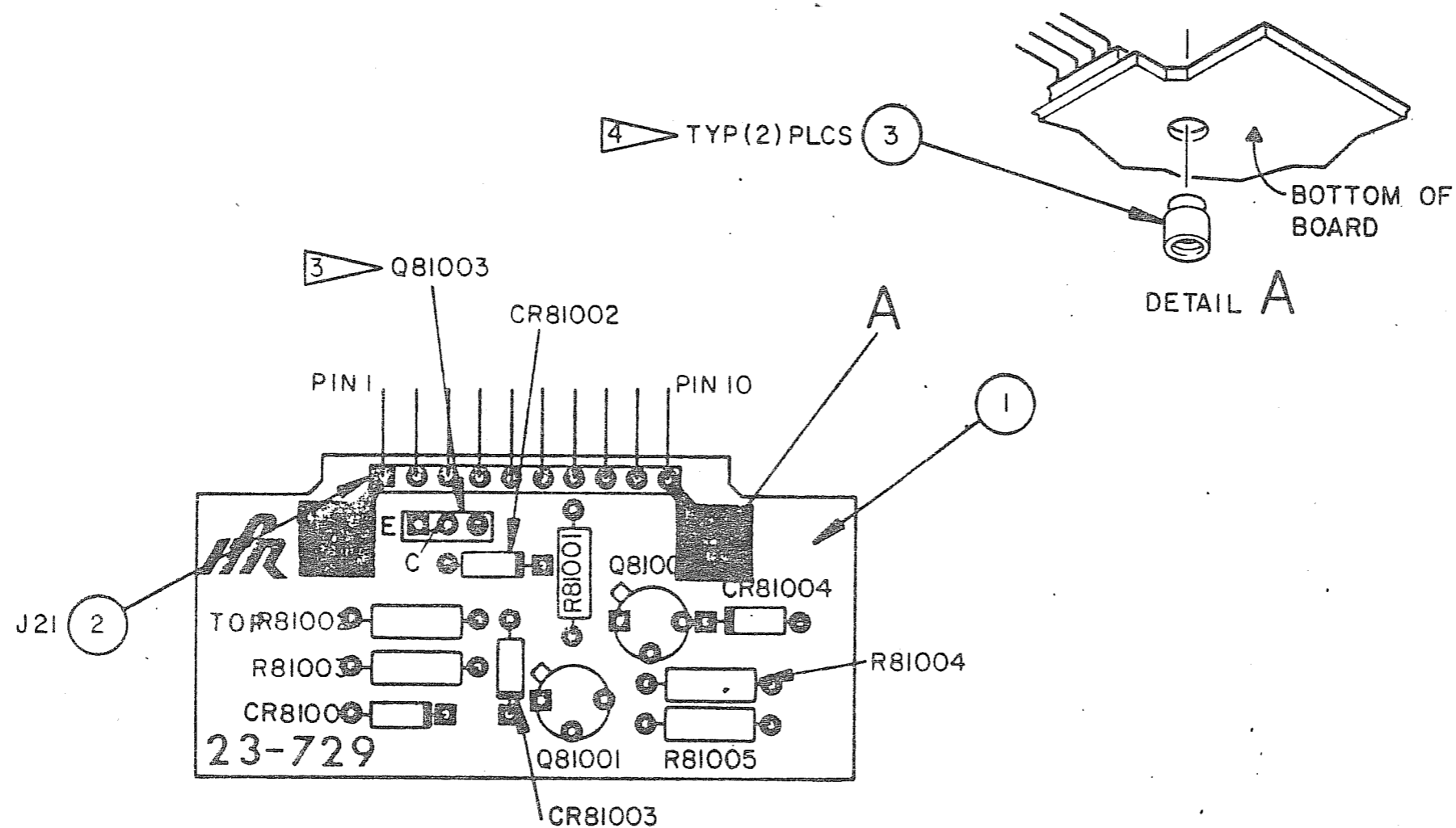

NOTES:

1. FOR CABLE INTERCONNECT SEE 0000-2364-001.
2. REFERENCE CIRCUIT SCHEMATIC 0000-2372-800.
3. INSTALL Q81003 TRANSISTOR WITH METAL BACK TOWARDS J21 CONNECTOR.
4. SOLDER ITEM 3 (# 2800-0000-007) IN PLACE ON BOTTOM OF BOARD.

ITEM	REQ'D	PART NO.	DESCRIPTION
LIST OF MATERIALS			
TOLERANCES UNLESS OTHERWISE SPECIFIED ALL DIMENSIONS APPLY AFTER FINISH		DRAWN DATE ER 5/21/80	- IFR INC - WICHITA, KANSAS
DECIMALS .010		CHECKED DATE J. Adams 11-6-80	TITLE RELAY DRIVER P.C. BD. ASSY.
ANGLES 1/2°		APPROVED DATE BOROTA 11/6/80	FM-AM 1000 S
FRACTIONS 1/32		MATERIAL — / —	SIZE B
SURFACE ROUGHNESS REMOVE ALL BURRS		FINISH — / —	PART NUMBER 7010-2373-100
		SCALE 2 X 1	WEIGHT — / —
			SHEET OF

